

# F-MAX USER MANUAL



Sharing the load

This manual shall not be reproduced, reprinted, or stored in an IT system without prior written approval of Ford Otomotiv Sanayi A.Ş. It shall not be published or recorded electronically, mechanically, photographically or by any other means. It shall not be translated into another language, modified or supplemented in any way. The points specified above are valid for the sections of this manual, too.

This manual intended to inform Ford owners of about the maintenance and operation of the vehicle and despite the fact that maximum efforts have been made to ensure that the information contained during the preparation of this manual was correct and complete, Ford Otosan shall not be held responsible for any missing or incorrect information.

Some of the illustrations in this manual may show features as used in different models, thus some features may appear different on your vehicle, however, the essential information in the illustrations is always correct.

This manual describes product features and options available throughout the range, sometimes even before they are generally available. Thus, some of the features here may not be available in the vehicle you purchased. The information contained in this manual does not constitute an offer for sales or a guarantee that such features are available on the vehicle.

The pictures, technical information and descriptions contained in this manual were valid at the time of print. In the interest of continuous development the right is reserved to change specifications, design or equipment at any time without notice and without incurring any obligations.

If you have any doubts about the features of your vehicle, please consult a Ford Otosan dealer considering that the standard and optional features of the vehicles are subject to change from time to time.

Important: Ford genuine parts and accessories have been specifically designed for Ford vehicles. These are suitable for your vehicle.

We would like to point out that other parts and accessories than mentioned above have not been examined and approved by Ford unless explicitly stated by Ford. In spite of continuous market product monitoring, we cannot certify the suitability of such products. Ford is not liable for any damage caused by the use of such products.

© September 2022 Ford Otomotiv Sanayi A.Ş. All rights reserved.

# Table of Contents

<b>INTRODUCTION</b>	<b>1</b>	Circuit Breakers .....	89	Electrical Systems.....	198
Accessories and Parts .....	2	A/C and Heater.....	90	Changing Bulbs .....	209
Dashboard.....	4	Driving .....	102	Locations of the Tools in the Vehicle .....	212
Seat Belts .....	7	Braking.....	115	Questions and Remedies .....	213
Park Brake Control .....	9	Shifting .....	125	<b>TECHNICAL SPECIFICATIONS</b>	<b>216</b>
General Safety Warnings.....	11	Power take off.....	132	Labels.....	217
<b>CONTROLS AND INDICATORS</b>	<b>15</b>	While driving.....	133	Fluid Filling Capacities.....	218
Instrument Panel .....	16	ECAS (Electronically		Engine Specifications .....	220
Trip Computer .....	29	Controlled Air Suspension) .....	136	Transmission Specifications .....	221
Control Buttons.....	40	EBS-ESP .....	138	Installation of Upper structure .....	222
<b>MULTIMEDIA</b>	<b>46</b>	Differential Lock.....	140	<b>AUXILIARY HEATER</b>	<b>236</b>
Audio Unit.....	46	Lane Departure Warning System .....	142	Airtronic/Airtronic M .....	236
Multi-functional Handles .....	53	Driver evaluation function .....	150	Hydronic M-II .....	288
Tachograph.....	56	Accessories .....	151	<b>ANNEXES</b>	<b>339</b>
Tachograph Simulator Unit .....	63	Useful Information.....	152	Declaration of Conformity.....	339
<b>OPERATION</b>	<b>64</b>	<b>MAINTENANCE AND SERVICE</b>	<b>155</b>		
Opening and closing of the vehicle .....	65	Attaching and Detaching a Trailer .....	156		
Cab Ventilation.....	70	Fuel Quality and Refuelling .....	162		
Seats and Beds .....	71	Exhaust System .....	163		
In-cab storage compartments.....	77	Urea System.....	167		
Steering Wheel.....	80	Tires and Wheels.....	170		
Mirrors .....	81	Driver Cab .....	179		
Lighting.....	82	Engine .....	184		
Window Washing and Heating Systems .....	87	Steering Wheel .....	195		
		Towing the Vehicle.....	196		

# About This Manual

## ABOUT THIS MANUAL

Thank you for choosing Ford. We recommend that you take some time to get to know your vehicle by reading this manual. The more that you know about it, the greater the safety and pleasure you will get from driving it.

Also some features may be explained although they are not introduced because of the time periods between the dates of issue.

Regular servicing of your vehicle helps maintain both its roadworthiness and its resale value.

More than 100 Ford Authorized Dealerships around the world will offer you help with their professional service experience.

Authorized Dealerships provide you the best expert service with their specifically trained personnel. Moreover, they are supported with a wide range of tools and equipment specially developed for applying service on Ford vehicles.

Note: Remember to pass on the Owner's manual when reselling the vehicle. It is an integral part of the vehicle.

All technical information and data included in this manual are valid in the issue date of this manual. However, we reserve the right to make changes without prior information due to our continuous product development policy as  
FORD OTOSAN.

Some features described in the user manual may not be present in your vehicle depending on the vehicle model.

**Regards,  
FORD OTOMOTİV SANAYİ A. Ş.**

**For Diesel Vehicles  
CAUTION !**

Use only EN590 compliant, high quality fuel (Eurodiesel) with low ratio of sulphur. Fuel-related faults that may occur when EN590 compliant, high quality fuel (Eurodiesel) with low ratio of sulphur is not used shall be considered out of warranty cover.

**FORD OTOSAN**

# INTRODUCTION

1



# 1 INTRODUCTION

## Accessories and Parts

### PARTS AND ACCESSORIES

Your Ford has been built to the highest standards using high quality Ford Original Parts. You may enjoy driving your vehicle for years.

We advise you to use Ford Original Parts only when an unexpected situation occurs and a part should be replaced.

The use of Ford Original Parts ensures that your vehicle is repaired to its pre-accident condition and maintains its maximum residual value.

Ford Original Parts complies with the strictest safety conditions and highest safety standards of Ford. Thus, they offer the best total repair cost including the costs of parts and labor.

Now it is much more easier to understand if the part offered to you is a Ford Original Part. Ford Original Parts listed below have a Ford logo on them.

Inspect whether the part has a Ford logo in case of a repair, and make sure that Ford Original Parts are used.

### Symbols on your vehicle



When you see these symbols, refer to the relevant section of this manual before touching any part or attempting an adjustment of any kind.

### SYMBOLS GLOSSARY

#### Symbols in this manual



#### WARNING

If you do not follow the instructions marked with the warning symbols, you may expose yourself and others to an accident resulting in death or injury.



#### CAUTION

You risk damaging your vehicle, if you do not follow the instructions highlighted by the caution symbol.

## ACCESSORIES, SPARE PARTS AND MODIFICATIONS

Today, there are many non-original parts and accessories are being sold in the market for FORD CARGO vehicles. Using these type of non-original FORD CARGO parts and accessories (even these parts are authorized by some institutions in your country) may have an adverse effect on the safety of your vehicle. Therefore, non-original FORD TRUCKS parts and accessories and problems likely to result from the usage of these are not considered under warranty and this does not put FORD CARGO under any liability.

No modifications should be performed on this vehicle. Any modification on your vehicle could effect your vehicle's performance, safety, and durability, and it might also be against legal regulations. Additionally, any damage and performance problems due to the modification of your vehicle are not considered under warranty cover.

**FORD OTOMOTİV SANAYİ A. Ş.**

# 1 INTRODUCTION

## Dashboard

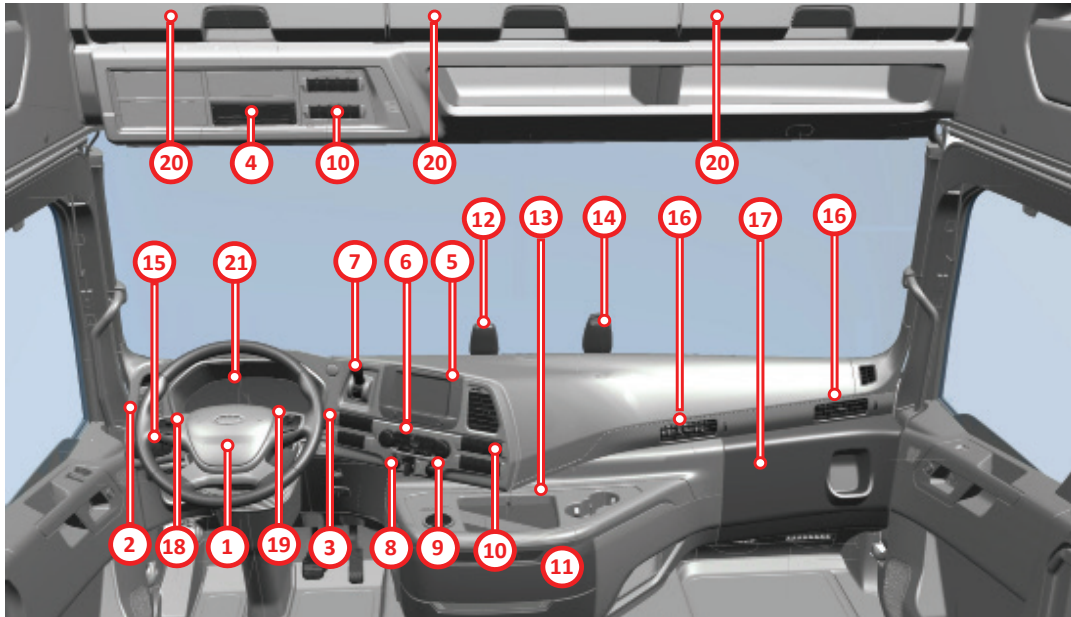



1	Steering Wheel
2	Multi-functional handle (left)
3	Multi-functional handle (right)
4	Tachograph
5	Information and Entertainment display
6	Climate-Control
7	Parking brake
8	Lighter / 12V outlet-20A
9	24V outlet-15A
10	Control Panel/Control Buttons
11	Centre console storage compartments

12	Camera
13	Centre console / Bottle holders
14	Rain sensor
15	Headlamp control panel
16	Ventilation and A/C heater air outlets
17	Fuse cover
18	Cruise control
19	Audio control
20	Storage compartments
21	Digital indicator

# SAFETY

2



Seat belts provided with your vehicle are the most important on-board safety equipment.

Seat belts minimize the risk of injury by reducing the movement of the occupants in the direction of impact and their contact with the interior in case of a crash.

Always fasten your seat belts while driving. Seat belt shall not loose or bent or shall not be blocked by another occupant or load.



### WARNING

Seat belt cannot provide its protection function if you do not fasten it correctly or ensure that the belt lock is engaged properly. Otherwise, you may get seriously or fatally injured in case of an accident. Ensure that all occupants of the vehicle have properly fastened their seat belts to prevent this.



### WARNING

Always ensure that the seat belt passes over the hip area, not over the abdominal area; that it is tensioned, and not bent in any way; that it passes from the center of the shoulders, not from the neck area or from the armpits; that it is pulled upwards from the chest area and that it is tensioned on the hip area. Do not fasten the belt with heavy items and avoid wearing thick clothes.

Do not fasten the seat belt over fragile objects in or on your clothes such as glasses, keys, pens etc.

Use a seat belt for only one person. Never travel with your children on your lap and do not fasten the seat belt over them.



### WARNING

Seat belts provide safety inside the vehicle when the occupants are seated in vertical position while the backrests of the seat are in vertical position.

Avoid seating position that prevent correct operation of the seat belts.

Do not drive while the backrest is leaned backwards excessively.



### WARNING

#### SEAT BELT REMINDER

The system only provides protection when you wear your seat belt correctly.

A warning light lights up and a beep sounds in the following situations:

- Driver seat occupied or front seat occupied.

- The front seat belts are not fastened.
- Your vehicle exceeds a relatively low speed.

The warning light also comes on when the front seat belt is removed while your vehicle is moving.

If you do not fasten your seat belt, the audible and visual warnings will stop after about five minutes.

# SAFETY

## 2

### Seat Belts



#### WARNING

Seat belt cannot provide proper functionality when the belt or lock of the seat belt is damaged. To prevent this, check the seat belts for damage or jamming periodically.

Otherwise, seat belt may be torn in case of an accident and cause serious or fatal injuries.

Do not perform any repair or modification on the seat belts, contact the authorized service in case of a damage to the belt. Fasten your seat belt before starting your vehicle.

#### Fastening the seat belt

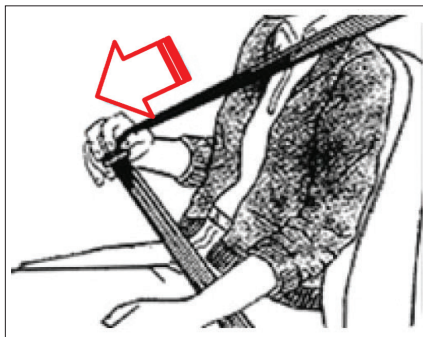

Pull the seat belt continuously from the reel. Seat belt may be locked when it is pulled too fast or when the vehicle is on a slope. In this case, relieve the seat belt and allow it to retract a little, then try again. Hear the locking click when you are inserting the latch of the seat belt to the buckle. Otherwise, seat belt is not locked. Adjust the height of the seat belt as per your your shoulder. (If height adjustment feature is available)

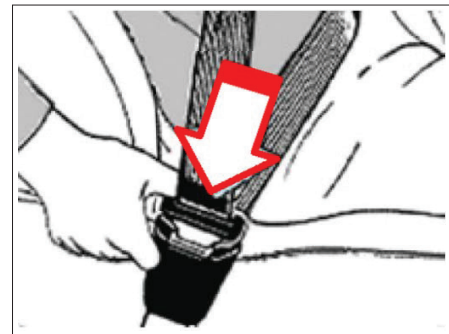

**Press the red button on the buckle to release the seat belt. Then, release the belt slowly to allow that it is wound on the reel fully.**

Seat belt shall pass through the middle of your shoulder. And, the waist part shall be seated firmly on your hips, not on your stomach.

# SAFETY

2

## Park Brake Control

Park brake is placed on the front console. Always apply the park brake after parking the vehicle. Check the tires if the vehicle is parked on a slope.

### Park position

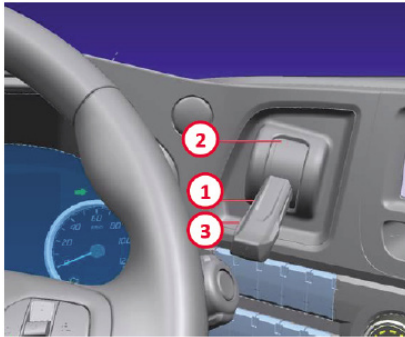

Bring the park brake lever to position 1. When the park brake is engaged, the display flashes red. 

### Drive position:

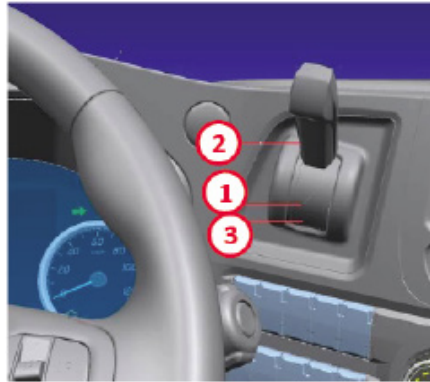

Bring the park brake lever to position 2.

### WARNING

Do not apply the park brake while the brake drums or disks are very hot, wait for them to cool.

### Test Position

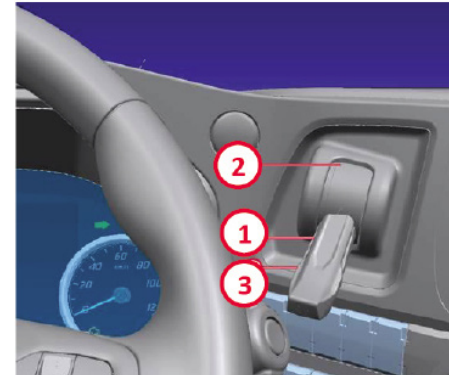

After taking lever to position 1, check whether the vehicle with semi-trailer moves by pressing on the lever and pulling the lever down (position 3). Then, bring the lever to park position (position 1) again. Then, get off the vehicle and apply the trailer park brake.

# SAFETY

## 2

### Park Brake Control



#### WARNING

Park brake is spring type. If there is not enough pressure in the air tanks, park brake will not be released from the control lever.

There shall be enough air pressure on the tanks to release the brake. If it is not possible to provide the air required, you may discharge the brake by rotating the spring of the setting bolt on the park brake bellows.

Before releasing the park brake spring, ensure the safety of your vehicle by chocking the wheels. Do not drive the vehicle if any park brake circuits are not working. Bellows may be frozen if the brakes cannot be released while the lever is released on winter. Spring is installed by rotating the bellows installation bolt in the tightening direction. To ensure that the emergency spring is fully installed, the setting bolt shall be tightened until it does not turn any more.



## General Safety Warnings

One of the most important safety elements on your vehicle is the tires. Check the tire pressure and condition periodically. Do not drive your vehicle with worn tires. When the tire pressure is very low, tires may get extremely heated and worn and these may cause excessive fuel consumption.

When the tire pressure is very high, this may cause longer braking distance, worse handling and excessive wear on tires. If the pressure loss happens continuously, this may be caused by external damages, cracks, foreign material in the tires and faulty tire valves leaking air.

 **WARNING**

Please, observe the prescribed tire pressure for your vehicle.

Very low tire pressure may cause blowout of the tire at high speeds and loads. You can cause an accident and thus injuries to others due to this.

### Tire profiles

A minimum profile depth is prescribed for tires by law. Observe the legislation for the relevant country.

For safety reasons, change your tires before reaching the legally advised minimum profile depth.

 **WARNING**

An excessively low tire profile may cause loss of handling at high speeds in case of rain or snow mud conditions. You may lose your handling and cause an accident in these conditions.

### The Condition of the Tires

Check the following conditions regularly every 2 weeks and before a long haul to inspect the condition of the tires:

- External damage
- Cracks and bulges on the tires,
- Foreign material in the tire profile,
- Irregular wear of the profile.

 **WARNING**

Do not forget that the external damages, bulges and cracks on the tires may cause blowout of the tire. You may cause an accident in these conditions.

### The Aging of the Tires

Aging of the tires reduce the operation and traffic safety of the tires. Even unused tires are aged.

Always replace your tires if they are aged more than 6 years.

### Tire Damages

Tire damages are usually caused by the following reasons:

- Aging of the tire
- Foreign material
- Usage conditions of the vehicle
- Weather conditions
- Oil, fuel, grease etc. - Contact with materials
- Dragging on the sidewalks
- Low or high tire pressure

 **WARNING**

When your vehicle passes over the sides of the sidewalks or objects with sharp edges, this may cause damages that cannot be seen externally.

These damages can only be noticed in the future and cause a flat tire. Do not park your vehicle with some part of the tire on the sidewalk.

# SAFETY

## 2

### General Safety Warnings



#### WARNING

Failure to observe following conditions may cause accidents which may result in serious injuries.

- Using a mobile phone while driving may distract you.
- Do not adjust the seat and steering wheel while driving.
- Occupants travelling on any other place than seats (e.g. on the bed) may cause serious injuries while braking.
- Do not put load on the beds inside the cab. This may cause serious injuries while braking.



#### WARNING

Make sure that the heater is off before refuelling of the vehicles with additional fuel tank for additional cab heater.



#### WARNING

Do not carry or store material harmful to the health inside the driver cab.

Examples of these materials are:

- Fuel
- Acid
- Lubricants and grease
- Cleaning agents

#### Vehicle Tracking Safety System

Fleet tracking systems are also used for finding the location of the vehicle in case of car theft.

However if the vehicle tracking module is removed, the location of the vehicle can not be found.

Vehicle Tracking Safety System eliminates this problem which is the weak point of the fleet tracking systems, since the module can not be removed and prevents the stolen vehicle from being driving away.

In vehicles with optional vehicle tracking safety system, starting may be last up to 35 seconds when the disconnecting switch shut off because of the safety package.

After the ignition is on, wait for the red immobilizer light  to dim out before starting.

If the instrument panel and FMS can not communicate while the ignition is on, the vehicle can not be started.

This prevents the starting of the vehicle without GPS tracking. Vehicle can not be started and indicates a warning in this case.

#### Cleaning of Exhaust Filter

The exhaust filter found in Euro 6 vehicles retains the smut coming from the exhaust gas and decreases the emission values. With the exhaust filter cleaning operation which can be performed automatically or manually, the smut retained in the filter is burned with regular intervals so that the filter is emptied before filling up and being clogged. In this operation, the exhaust gas is heated by the engine and smut is burned. Driver is informed about the exhaust filter cleaning of the vehicle through the messages displayed on the indicator panel and explained in detail in the Exhaust Filter Cleaning section



#### WARNING

Since the exhaust gas shall heat up during the exhaust filter cleaning; ensure that the vehicle is not in the same place with flammable, inflammable and explosive materials or in enclosed space



## General Safety Warnings



### WARNING

Ensure that vehicle exhaust cleaning is not performed in locations like hazardous material loading and unloading places or fuelling stations. When necessary, activate the exhaust filter cleaning prevention using exhaust filter cleaning prevention button



### CAUTION

Using exhaust filter cleaning prevention for prolonged time may cause the exhaust filter to be clogged and rendered unusable. Please observe the warnings provided in the indicator panel and do not use manual filter cleaning prevention unless necessary.

### U-bolt nuts

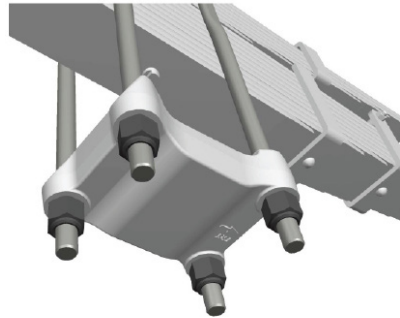

### WARNING

It is recommended, for a longer life of the springs, that you have the spring U-bolt nut torques checked between the first range of 2.000 km and 5.000 km (for once).

### Emergency lock



There are emergency locks on both the left and right doors of your vehicle.

Lock is integrated to the door on the area shown in the figure, and if you need to leave the vehicle when your batteries have run out or in case of a power problem, you shall rotate the emergency lock to lock the doors.

Doors remain locked if the doors are closed after rotating the emergency lock. Emergency lock is rotated with the metal handle, it is possible to lock and unlock both.

# SAFETY

## 2

### Damper Learning Procedure

Process steps of damper learning

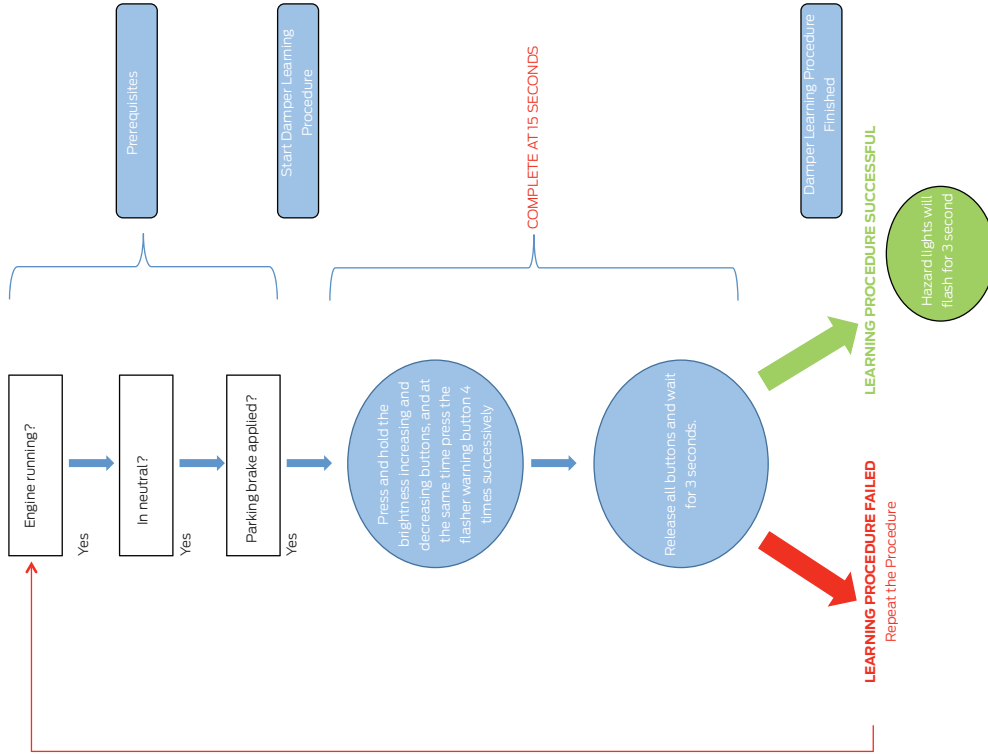

# CONTROLS AND INDICATORS

# CONTROLS AND INDICATORS

## Instrument Panel

3



























1	Tachometer
2	Engine coolant temperature gauge
3	Fuel gauge
4	Trip computer
5	Urea level gage
6	Engine oil pressure/brake air pressure indicator
7	Speedometer

# CONTROLS AND INDICATORS

## Instrument Panel

3







FUNCTION	SYMBOL	COLOR	BUZZER
Retarder		Green	n/a
Trailer ABS/EBS		Yellow	n/a
Park Brake Sign		Red	n/a
Engine brake		Yellow	n/a
Cleaning of Exhaust Filter		Green	n/a
Seat belt warning		Red	yes
Cab raised warning		Red	yes
Low urea level		Yellow	yes
Front Fog Light		Green	n/a
Trailer right/left turn signal warning		Green	n/a
Alternator / Charging system		Red	yes
Park lamp indicator warning		Green	n/a
Rear Fog Lamp		Yellow	n/a
Main Beam		Blue	n/a









FUNCTION	SYMBOL	COLOR	BUZZER
Engine fault lamp		Yellow	n/a
Oil level warning		Yellow/Red	yes
Oil Pressure Warning		Green	yes
High Engine Water Temperature		Red	yes
High Exhaust Temperature		Yellow	yes
Cold Starting Aid		Yellow	n/a
Fuel Level warning		Yellow	yes
High Air Pressure 1		Red	n/a
Low brake air pressure		Yellow/Red	yes
High Air Pressure 2		Red	n/a
Icing warning		Yellow	n/a
Emergency braking system		Yellow	yes
Lane departure warning system warning		Yellow	n/a
ESP		Yellow	n/a

# CONTROLS AND INDICATORS

## Instrument Panel

3

FUNCTION	SYMBOL	COLOR	BUZZER
Cruise Control		Grey/ Green	n/a
Adaptive speed control system		Grey/ Green	n/a
Exceeding of speed limit (Optional)	>120	Yellow	yes
Hill launch assist active		Yellow	n/a
Damper lifting		Red	yes
Information warning	<b>i</b>	Red/ Yellow	n/a
Tire pressure warning		Yellow	yes
MIL (malfunction indicator lamp)		Yellow	n/a
Map Assisted Speed Control System		Grey/ Green	n/a











FUNCTION	SYMBOL	COLOR	BUZZER
Map Assisted and Adaptive Speed Control System		Grey/ Green	n/a
Immobilizer		Red	n/a
Auxiliary heater (Dry type)		Yellow	n/a
Auxiliary heater (Wet type)		Yellow	n/a
Right Signal Lamp		Green	yes
Left Signal Lamp		Green	yes
Speed limiter		Grey/ Green	n/a
Auxiliary heater timing		Yellow	n/a
ESP Off		Yellow	n/a

# CONTROLS AND INDICATORS

## Instrument Panel

3











### Screen warning and error warnings...











SYMBOL	WARNING	WARNING DESCRIPTION
	Drive at constant speed for DPF regeneration.	Exhaust smut filter saturation is above the expected level. This might be caused by the style of driving or the driving time. For the vehicle to be able to conduct automatic filter cleaning, it is advised that you drive the vehicle with a fixed speed above 30kph when you see the green exhaust filter cleaning symbol. If the road conditions are not suitable, it is recommended to perform manual exhaust filter cleaning.
	Perform exhaust cleaning when parked for exhaust system efficiency (with the button).	Exhaust smut filter is filled to the extent that the vehicle cannot perform automatic cleaning. In this case; park the vehicle to a safe location and make sure that the vehicle is not in contact with any flammable material, and then perform manual cleaning using the manual cleaning button. You can find manual cleaning conditions in the manual exhaust filter cleaning section.
	Exhaust filter is too full.	Exhaust filter is too full. Press the button for exhaust cleaning when parked.
	Reset manual inhibition when possible.	Exhaust filter started to fill up excessively while the manual exhaust filter cleaning prevention is active. It is recommended that you lift the exhaust filter cleaning prevention before the filter is overloaded or allow manual filter cleaning. You can remove the filter cleaning prevention by keeping the filter cleaning prevention button for 3 seconds or by restarting the engine after turning off the ignition.
	DPF regeneration is active. Remaining: X min.	Manual exhaust filter cleaning is active During exhaust filter cleaning, the exhaust gas temperature is increased to burn the soot inside the exhaust filter. Time remaining to the end of operation is shown in minutes.
	Regeneration can not be activated. Conditions are not met.	Conditions are not suitable for manual exhaust filter cleaning. In this case, you have to ensure that the conditions written in the manual exhaust filter cleaning section are met
	The exhaust filter could not be cleaned while driving.	The exhaust filter could not be cleaned while driving. Clean the exhaust when parked.
	DPF regeneration inhibition is set by driver.	Exhaust filter cleaning prevention is activated by the driver. You can activate the exhaust filter cleaning prevention while loading hazardous materials or while driving the vehicle in an environment with flammable materials like grass, hay, petroleum products etc. Please keep in mind that the exhaust filter will be damaged in long blocking durations.
	The exhaust is cleaned with high temperature gas. Pay attention to the vehicle environment.	This warning is for the purpose of informing the driver. Exhaust gas temperature is high due to driving under heavy load or exhaust filter cleaning. This warning is activated when the exhaust gas temperature is high and the vehicle speed is low. It is normal to see this warning during exhaust filter cleaning. When the warning is active, please ensure that the vehicle and exhaust fumes are not in the same environment as flammable materials like grass, hay, petroleum products etc. and that the vehicle is not in an enclosed area. Otherwise, fire risk may occur!
	Poor Urea Quality. Use high quality urea for exhaust system efficiency.	Material not conforming to ISO22241-1 standards detected in urea tank. Drain the urea tank and add urea that conforms to the standards. Resolve the problem as soon as possible to prevent power cut off.

# CONTROLS AND INDICATORS

## Instrument Panel

3

SYMBOL	WARNING	WARNING DESCRIPTION
	Apply brake pedal test. See Manual	Have the brake pedal test performed
	Low battery level. Crank the engine to refill the battery	Start the engine to charge the battery.
	AEBS malfunction. Service required.	AEBS malfunction. Service required.
	Brake air pressure is high.	Brake air pressure is high.
	Low tire pressure sensor battery.	Service required.
	Engine will shutdown soon. Press any pedal to cancel.	Engine will shutdown soon. Press any pedal to cancel.
	ATG active	ATG active warning
	Warning, clutch overheated	Clutch lining failure
	Warning, clutch protected	Clutch lining failure
	High Speed	High speed warning





















SYMBOL	WARNING	WARNING DESCRIPTION
	Urea dosing malfunction. Service required.	Error detected in urea dosing system. Please drive to service to prevent power cut off.
	Critical emission error	Critical emission error. Perform Exhaust Filter Cleaning.
	Urea level low. Please fill up urea.	There is not enough level of urea in the urea tank. Please add urea that conforms to the standards in order to prevent power cut off.
	Urea level low	Urea level low in urea tank. Please add urea that conforms to the standards in order to prevent power cut off.
	Check engine oil level.	Oil level warning
	ECAS warning active	Air suspension warning active
	Engine oil change is due.	Oil replacement warning
	Air filter intake restriction.	Service required.
	Steering oil pressure is low. Please fill up oil.	Oil level shall be checked when lit. If there is a leakage, request road assistance. If there is no leakage, drive to the nearest workshop without exceeding 50 km/h speed.
	Fuel filter is blocked. Service required.	Service required.



# CONTROLS AND INDICATORS

## Instrument Panel











3











SYMBOL	WARNING	WARNING DESCRIPTION	SYMBOL	WARNING	WARNING DESCRIPTION
	Engine coolant level is low.	If the warning lamp is not turned off after top up, the vehicle should be taken to the nearest workshop as soon as possible.		Passenger side door is open	Door open warning
	Discharge the water in the pre-filter water tank	Drain the water in the pre fuel filter water container, and if the lamp is not turned off, the vehicle should be taken to the nearest workshop as soon as possible.		Speed limiter will be active after 60 seconds.	Speed limiter will be active after 60 seconds.
	Front radar sensor blocked. See Manual.	Front radar sensor blocked. See Manual.		40 km/h speed limit is exceeded. Slow down.	40 km/h speed limit is exceeded. Slow down.
	Front camera malfunction. Service required.	Front camera malfunction. Service required.		ACC not available.	ACC not available.
	Front camera low visibility. See Manual.	Front camera low visibility. See Manual.		Water type heater failure. Heater will not be active	Water type heater failure. Heater will not be active
	Avoid idling for long periods to decrease fuel consumption.	Avoid idling for long periods to decrease fuel consumption.		Air type heater failure. Heater will not be active	Air type heater failure. Heater will not be active
	AEBS does not support trailer brake system.	AEBS does not support trailer brake system.		Parking heater is active	Parking heater is active
	4,5 hours driving time is complete. Take a break.	Tachograph break time		Please shift the transmission to neutral.	Please shift the transmission to neutral.
	Oil level measurement problem. Service required.	Service required.		CC not available. Disengage auxiliary brakes.	CC not available. Disengage auxiliary brakes.
	Driver side door is open	Door open warning		Too much MyView screens. Delete a screen to add a new screen.	Too much MyView screens. Delete a screen to add a new screen.

# CONTROLS AND INDICATORS

## Instrument Panel

3



















SYMBOL	WARNING	WARNING DESCRIPTION
	Brake air pressure is low.	Brake air pressure is low.
	Low tire pressure.	Low tire pressure.
	Extreme low tire pressure	Extreme low tire pressure
	High tire pressure.	High tire pressure.
	High tire temperature.	High tire temperature.
	Update conditions are not met. See Manual.	See Manual.
	Update failure. Call Service.	Call service.
	Software update is in progress. Do not turn off power.	Software update is in progress. Do not turn off power.
	Update failed. Previous version is in use.	Update failed. Previous version is in use.
	Update is interrupted. Please start again.	Update is interrupted. Please start again.

SYMBOL	WARNING	WARNING DESCRIPTION
	Update is successful. Turn ignition OFF & ON	Update is successful. Turn ignition OFF & ON
	ADAS MAP programming is in progress. Do not turn off power.	ADAS MAP programming is in progress. Do not turn off power.
	ADAS MAP update is successful.	ADAS MAP update is successful.
	ADAS MAP update has failed	ADAS MAP update has failed
	Avoid harsh acceleration	Avoid harsh acceleration
	Deactivate auxiliary brakes.	Deactivate auxiliary brakes.
	Use auxiliary brakes.	Use auxiliary brakes.
	Avoid harsh braking	Avoid harsh braking
	Excellent braking.	Excellent braking.
	Good braking	Good braking

# CONTROLS AND INDICATORS

## Instrument Panel









3









SYMBOL	WARNING	WARNING DESCRIPTION	SYMBOL	WARNING	WARNING DESCRIPTION
	Poor braking.	Poor braking.		Poor anticipation.	Poor anticipation.
	Consider using cruise control	Consider using cruise control		Reduce speed to decrease fuel consumption.	Reduce speed to decrease fuel consumption.
	Consider using adaptive cruise control	Consider using adaptive cruise control		Avoid kick-down to decrease fuel consumption.	Avoid kick-down to decrease fuel consumption.
	Consider using MaxCruise	Consider using MaxCruise		Maintain a steady vehicle speed.	Maintain a steady vehicle speed.
	Curve ahead: Reduce speed.	Reduce your speed.		Differential lock is active.	Differential lock is active.
	Descent ahead: Reduce speed.	Reduce your speed.		PTO is active.	PTO is active.
	Ascent ahead: Increase speed.	Increase your speed.		Vehicle front suspension level raising.	Vehicle front suspension level raising.
	Decelerate by coasting to decrease fuel consumption	Reduce your speed.		Vehicle rear suspension level 2 set.	Vehicle rear suspension level 2 set.
	Excellent anticipation.	Excellent anticipation.		Good anticipation.	Good anticipation.

# CONTROLS AND INDICATORS

## Instrument Panel

3











SYMBOL	WARNING	WARNING DESCRIPTION
	Vehicle is not at optimum ride height	Vehicle is not at optimum ride height
	Critical brake pad health. Performance is reduced. Service required.	Critical brake pad health. Performance is reduced. Service required.
	Low brake pad health. Service required.	Low brake pad health. Service required.
	Adaptive Cruise Control	Adaptive Cruise Control
	Wheel sensor battery low.	Wheel sensor battery low.
	Sensor Learn is incomplete. Vehicle speed must be zero	Sensor Learn is incomplete. Vehicle speed must be zero
	Sensor Learn incomplete. RPM is not zero .	Sensor Learn incomplete. RPM is not zero
	Sensor Learn incomplete. Parking brake is not applied	Sensor Learn incomplete. Parking brake is not applied
	Sensor Learn is complete.	Sensor Learn is complete.











SYMBOL	WARNING	WARNING DESCRIPTION
	Do not leave the vehicle without applying parking brake.	Apply the Parking Brake
	The brakes become warmer, slow down and use the auxiliary brakes	The brakes become warmer, slow down and use the auxiliary brakes
	Advanced Emergency Braking	Advanced Emergency Braking
	Sensor Learn is incomplete. Session expired. Please try again.	Sensor Learn is incomplete. Session expired. Please try again.
	Sensor Learn incomplete. Sensor ID conflict.	Sensor Learn incomplete. Sensor ID conflict.
	Sensor Learn is in progress	Sensor Learn is in progress
	New soft ware update(s) available.	New soft ware update(s) available.
	End-of-Line parameters are not restored. Service required.	End-of-Line parameters are not restored. Service required.
	Software is up-to-date.	Software is up-to-date.

# CONTROLS AND INDICATORS

## Instrument Panel

3



SYMBOL	WARNING	WARNING DESCRIPTION
	MaxCruise is deactivated.	MaxCruise is deactivated.
	Automatic braking is turned off. Take over control.	Automatic braking is turned off. Take over control.
	Adaptive Cruise Control is deactivated.	Adaptive Cruise Control is deactivated.
	ACC is not available due to high brake temperature.	ACC is not available due to high brake temperature.
	ACC performance is reduced. Brakes are getting warmer	ACC performance is reduced. Brakes are getting warmer
	CC is active. Automatic braking is turned off	CC is active. Automatic braking is turned off
	Clutch Lining Failure	Clutch overheated under heavy strain.
	Clutch Lining Failure	Clutch wear is detected. Service required
	Transmission Temperature	Transmission temperature is too high.
	Transmission Automatic Control	Transmission self check is active
	Speed warning	Your speed is too high. Reduce your speed.

SYMBOL	WARNING	WARNING DESCRIPTION
	ACC not available. Sensor blocked. See Manual.	ACC not available. Sensor blocked. See Manual.
	Power (PWR) mode is active.	Power (PWR) mode is active.
	Rocking (ROC) mode is active.	Rocking (ROC) mode is active.
	Crank system fault Please wait	Crank system fault Please wait
	Key initialization error. Please try again.	Key initialization error. Please try again.
	Crank system cooling period. Please wait	Crank system cooling period. Please wait
	Gas Pedal	Release accelerator pedal
	Transmission Air Pressure	Transmission air pressure is too low.
	Speed alert	Your speed is too high. Reduce your speed.
	Critical Transmission Error	Transmission error, visit an authorized dealership immediately.

# CONTROLS AND INDICATORS

## Instrument Panel

3

SYMBOL	WARNING	WARNING DESCRIPTION
	Mechanical Maintenance Warning	Mechanical maintenance time is approaching.
	Mechanical Maintenance Warning	It is time for mechanical maintenance. Go to the service.
	Max Cruise Usage Recommendation	Consider use of MaxCruise for fuel savings up to 4%.

# CONTROLS AND INDICATORS

## Instrument Panel

Odometer

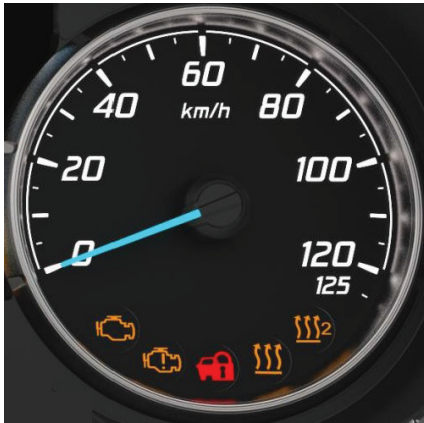

Indicates the road speed (kilometer/hour).

Tachometer

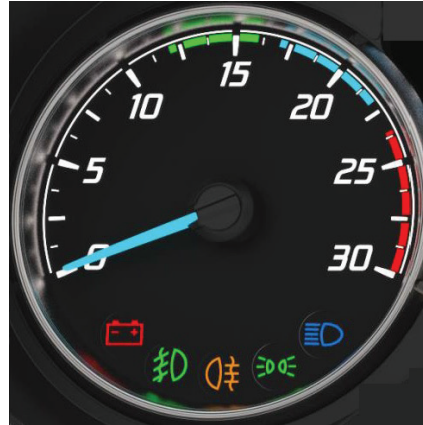

### CAUTION

3

Indicates the engine rpm. Operate your vehicle so that the indicator dial remains in the green zone as much as possible. Drive your vehicle considering the engine speed. Keeping engine speed in the green zone provides economy. Avoid excessive speeds in the red danger zone. Otherwise, your engine may get damaged. Ensure that the speed does not increase up to red danger zone, especially while driving down the hill.

Green zone: Economy zone

Blue zone: Zone where the engine brake is active

Red zone: Danger zone

Buzzer sounds when you exceed the maximum allowed engine speed. Lower the engine speed when you hear that warning. Engine brake is deactivated over 2400 rpm.

# CONTROLS AND INDICATORS

## Instrument Panel

3

### Engine coolant temperature gauge



Indicates engine coolant temperature. If the dial of the indicator is in the red area, the engine may overheat.



Red warning light is illuminated on the indicator and the buzzer sounds when the engine coolant temperature reaches 109 °C.

Your vehicle shall overheat when the temperature exceeds 107°C, and it shall reduce torque when the temperature exceeds 108°C. Perform the following when the red warning lamp is illuminated:

- Stop the vehicle and operate the engine in idle.
- Apply park brake, check for water leaks under the vehicle (do not get under the vehicle, check from the side.)
- Open the hood and check for the water level in the engine auxiliary water tank.
- If the water temperature does not drop, stop the engine and tilt the cab. Inspect whether the engine belt is broke.
- Check for water leaks in the thermostat area on the front of the engine.
- Ask the support of a Ford Trucks authorized dealership, if required.

### Fuel gauge



Indicates the fuel level in the tank Yellow warning light indicates that the fuel in the tank is reduced. Refill fuel immediately. System will take air if the fuel is lowered.



### Icing Warning

Icing warning light illuminates if the external temperature is below 4 degrees



# CONTROLS AND INDICATORS

## Trip Computer

### Air pressure indicator

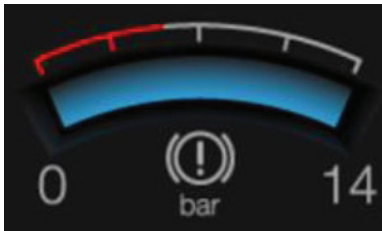

There are 2 independent air system circuits that supply for the front and rear brake systems. You can read the pressures of these systems from a single air pressure indicator.

Indicator shows the pressure value of the line with low pressure automatically.

If the indicator **1** shows the air pressure of the circuit, the  light is illuminated.

If the indicator **2** shows the air pressure of the circuit, the  light is illuminated.

Air pressure indicator always shows the air pressure of the circuit with the lowest air pressure. Normal operating range of the system is 10.5-12.5 bars.

### Air pressure audible warning

If the air pressure is reduced to a value under 5.5 bars, low pressure warning buzzer shall sound. Buzzer is turned off when system pressure reaches the normal operating pressure at both pressure circuits. Do not drive your vehicle before the audible warning is deactivated! If you hear the audible warning while driving stop your vehicle immediately. Block the wheels. Place road safety signs and call a Ford Trucks authorized dealer.

### Oil pressure gauge with adapter



Indicates engine oil pressure in "bars". Oil pressure varies according to the oil temperature and engine speed. Operating pressure: 3 bar @ 90 °C, 2500rpm. Idle pressure: 1.5 bar @ 90 °C, 550rpm. The warning lamp will be illuminated when the oil pressure is low.

Perform the following when the red warning lamp is illuminated:

- Park the vehicle in a secure place, stop the engine.

Contact a Ford Trucks authorized dealership.

# CONTROLS AND INDICATORS

## Trip Computer

3

### Trip Computer

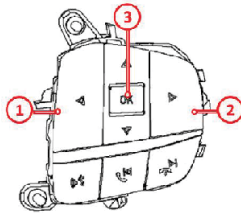

Trip computer shows the information and the warnings. Trip computer data may be changed by the control panel on the steering wheel.

**1-Left Direction Key:** Allows returning to an upper menu and moving to the left in the menus.

**2-Right Direction Key:** Allows moving to the right in the main menus.

**3-OK Key:** This key, which may be pushed up and down, allows easy up and down navigation in the menus.

Also, it allows entering the menus and using the “OK” function in the menus required.



When you press and hold the  key, and navigate to Indicator Selection from

the Vehicle Information Menu, and press and hold the OK key, the upper right indicator is selected as one of the brake air pressure or engine oil pressure.

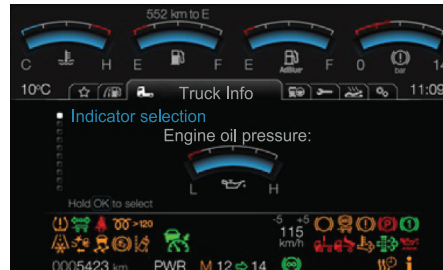

# CONTROLS AND INDICATORS

## Trip Computer

3



- 1 - Time:** Indicates the time period passed in the relevant trip.
- 2 - Mileage:** Indicates the mileage covered in the relevant trip.
- 3-Average Speed:** Indicates the average speed of the vehicle in the relevant trip.
- 4-Average Fuel:** Indicates the average fuel consumption of the vehicle for the relevant trip.



To reset the trip mileage, time and average fuel consumption information, press and hold the button on the screen in this menu.

- 1-Fuel Consumption -1:** Indicates the fuel consumed information for the trip in Trip 1 menu.
- 2-Fuel Consumption -2:** Indicates the fuel consumed information for the trip in Trip 2 menu.
- 3-Fuel Consumption -Total:** Indicates the average fuel consumed information for the period starting with the first operation of the vehicle.
- 4-Average Fuel Consumption:** Indicates the average fuel consumed information for the period starting with the first operation of the vehicle.

# CONTROLS AND INDICATORS

## Trip Computer

3

### Exhaust smut level information

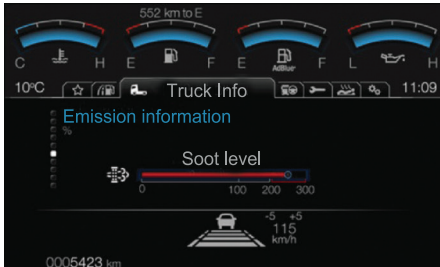

If the exhaust level is above 100%, the part between 0% and 200% of the bar will blink.

If the exhaust level is above 200%, the entire bar will blink.

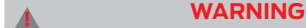

As changing trip computer display settings during driving can reduce the driving concentration and can pose a serious accident risk. Settings shall always be performed while the vehicle is parked.



This information informs that when an automatic software update is available, the engine is planning an update for its next stop. It is also activated when the contact is closed.

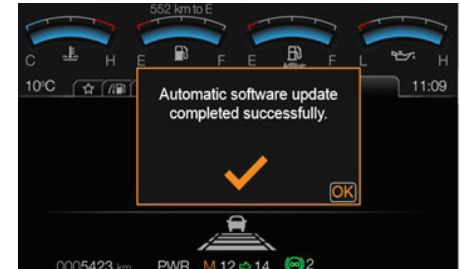

This information is activated when the automatic software update is completed.

# CONTROLS AND INDICATORS

## Trip Computer

3

### Tire Pressure and Temperature Monitoring System



**WARNING**

The fact that the vehicle is equipped with the tire pressure and temperature monitoring system does not cancel the requirement to check the tire pressures manually periodically. Check the tire pressures periodically using a pressure indicator. Failure to keep the tire pressures at correct value increases the risk for damage to tires, loss of handling, tripping over and personal injuries.

Inspect tire pressures (including the spare tire, if available) every two weeks while the tires are cold. Inflate the tires to the correct pressure.

Your vehicle is equipped with a tire pressure monitoring system as an assisting feature for the driver. A warning lamp is lit and an information message is displayed on the indicator if the pressure of one or more tire(s) is significantly raised or reduced, or if the temperature is significantly raised. Pressure and temperature values for each tire may be displayed on the relevant menu, and problematic values are indicated with orange and excessive reduction in pressure is indicated with red.

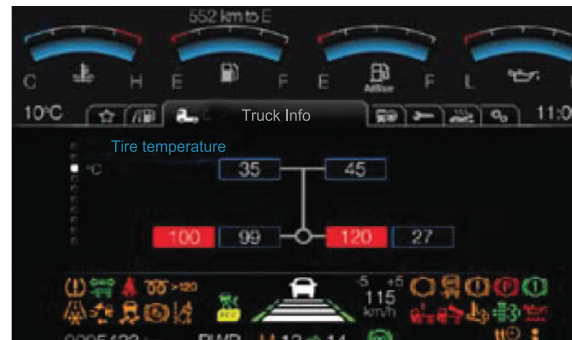

Stop the vehicle safely, inspect the tires and inflate them to correct pressure if the tire pressure low warning lamp is lit. This system does not replace correct tire maintenance procedures.

You may display tire temperatures by pressing the OK key on the steering wheel for a long time while displaying the tire pressures.

# CONTROLS AND INDICATORS

## Trip Computer

3

You shall ensure that the tire pressure are correct even if the tire pressure low warning lamp is not lit.

The tire pressure and temperature monitoring system is equipped with a system fault indicator to warn you when the system does not operate correctly. The function of the fault indicator and the tire pressure low warning lamp is common.

When the system detects a malfunction, the warning lamp shall flash for approximately one minute and then remain continuously illuminated. If the malfunction is resumed, this is repeated whenever you turn the ignition on.

System has detected a malfunction that requires servicing. If the fault indicator is lit, the system may not be able to detect or indicate a low tire pressure. Fault may be caused by many reasons such as installation of spare tires or rims that prevent the correct operation of the system.

Always check for tire pressure monitoring system fault warning after replacing one or more tires or rims on your vehicle.

Ensure that the spare tires or rims installed allow correct operation of the system.

### With Tire Pressure Monitoring System Replacement of Tires

Always have your tires inspected. We recommend you to contact an authorized service station.



**CAUTION**

**Note:** Each road wheel and tire is installed with a tire pressure sensor inside the groove of the wheel and tire assembly. Pressure sensor is installed to the valve body. Tire covers the pressure sensor and it is not possible to see the sensor without removing the tire. Be careful to prevent damage to the sensor while replacing the tire.

### Understanding Tire Pressure Monitoring System

System measures the pressure and temperature values on six tires at two axles and sends these values to the vehicle.

System detects the low pressure as significantly lower than the correct inflation pressure and the warning lamp is illuminated. Inflate the tires to the correct pressure.

An information message is displayed on the indicator when the system detects a high, low and excessively low tire pressure and a high tire temperature



**WARNING**

While the tires are inflating the system may not react immediately to the air added to the tires.

### Sensor Learning Operation

Sensors may be used after performing a learning operation when the tires are replaced, when a new a sensor is used and/or when their position on the vehicle are changed.

Select the location of the tire to be relearned after entering the TPMS “Tire Pressure Sensor Learning” under the “Maintenance” menu in the instrument panel, and keep the OK key pressed. Sensor is activated by increasing/decreasing the air pressure of the relevant tire when the message indicating that the sensor learning operation is started is displayed. A message indicating that the operation is completely successfully is displayed on the screen. Then the new sensor is learned and its location is specified.

Spare tire does not have a sensor at this moment, and the following label is attached to the tire.



# CONTROLS AND INDICATORS

## Trip Computer

3

### Connectivity (ConneCTruck) Settings

In order to use the services provided via ConneCTruck, the connectivity services for your vehicle should be selected from the “Connectivity” menu on the instrument panel. For this purpose, the “Connectivity” sub-menu under the “Settings” menu shall be selected.

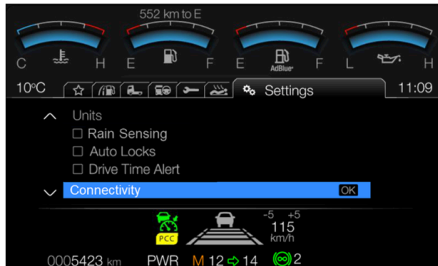

When the “Connectivity” sub-menu is opened, two options - “Connectivity Features” and “Vehicle Data and Location” - will be shown.

The “Connectivity Features” option is the main option and when it is turned off, all connectivity features of the vehicle will be completely disabled.

The “Vehicle Data and Location” option provides the option to send your vehicle’s location and other information to ConneCTruck servers. When this option is turned off, no ConneCTruck service will be available for location and vehicle information (example: **MyFordTrucks mobile app**) until you re-enable this option.

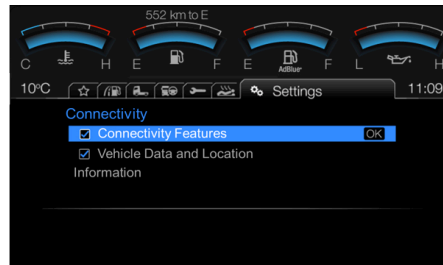

### CAUTION

In case of problems with ConneCTruck services, first make sure that both “Connectivity” options are selected.

Following the activation of ConneCTruck services, an active SIM card and  icon will appear on the display panel. This icon indicates that the GSM modem is active and operating.

When “Connectivity” and “Vehicle Data and Location” options are selected

together, the  icon indicates that your vehicle’s location and other information are being sent to ConneCTruck servers.

# CONTROLS AND INDICATORS

## Trip Computer

3

### Bodybuild Axle Weight Indicator

Information on the axle weights of the bodybuild, connected to the vehicle under the vehicle information menu, can be followed from the indicator.

If the bodybuild has a raisable axle, when this axle is raised up, it is seen in gray on the indicator as in the picture. Weight information does not come from the raised axle. Active axes are shown in blue.

In case there is no weight information from the bodybuild connected to the vehicle, all axles are seen in gray on the indicator. Any weight information of the bodybuild is not displayed on the screen.

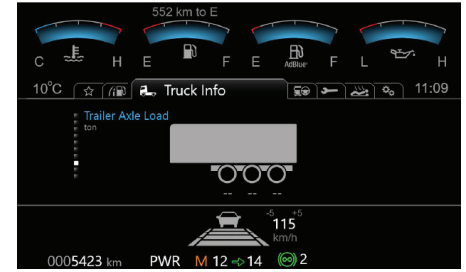
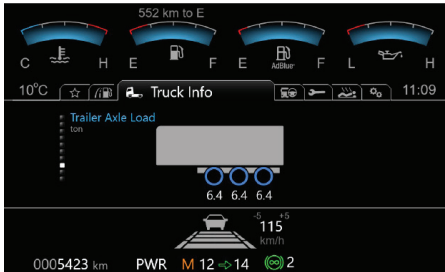



# CONTROLS AND INDICATORS

## Trip Computer

### Display of brake lining life



3

Symbol	Symbol Name	Remark
	Data is collected for calculation	For lining life mileage estimation calculation; data on the current vehicle usage conditions must be collected for a certain period of time. Please wait.
	Remaining Lining Life «km»	Estimated distance to be driven with the remaining lining (km)
	Fitting of lining worn below 35%	Go to the service.
	General Error	
	Lining Sensor Error	
	Different wearing between right and left lining	Go to the service.
	Remaining lining life below 6%	

# CONTROLS AND INDICATORS

## Trip Computer

3

### Eco Mode - Fleet Mode

Driving mode information is opened with the signal coming from the control module on the indicator screen. You can select the driving type from this screen.

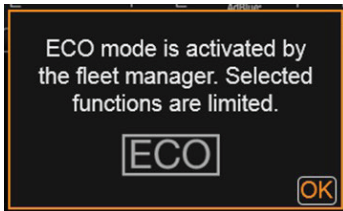

### Crawler Function (On vehicles with Eco-torq transmission)



For the details of operation, see Page 127

### Auxiliary Brake Deactivation Warning

Auxiliary brakes will be deactivated to prevent wheel locking by anti lock braking activity if there is a slippery ground. These auxiliary brake usage includes activation by lever and blending but does not include auxiliary brake usage during ACC.

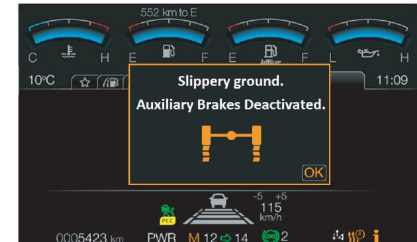

# CONTROLS AND INDICATORS

## Trip Computer

3

### Caution!

The system cannot detect a direct change when the oil is filled or drained. For the oil level display to be accurate, the engine must be stationary for 10 minutes after the engine has been switched off and on a level surface. Then, with the ignition in position two, engine off, the oil level will be checkable in 1 minute on the center display.

When the vehicle is in motion, the oil level menu will not appear on the center display.

### Oil Level Check

The oil level can be displayed with the engine off, ignition in position two, by selecting the oil level menu on the center display screen. The oil level information will be available within 1 minute after the center display screen is woken up.

In order for the oil level information to be correct, after the engine is switched off, the ignition must be kept in the ignition 0 position for at least 2 minutes on a flat surface. Then, 1 minute after the vehicle is turned to ignition 2 position, oil level information will be displayed on the center display screen.



When calculating the oil level information, the center display screen is as shown in the image.



OK: Indicates that the oil level is appropriate and above 20%.



LOW: Indicates that the oil level is not appropriate and is below 20%.

# CONTROLS AND INDICATORS

## Control Buttons

3

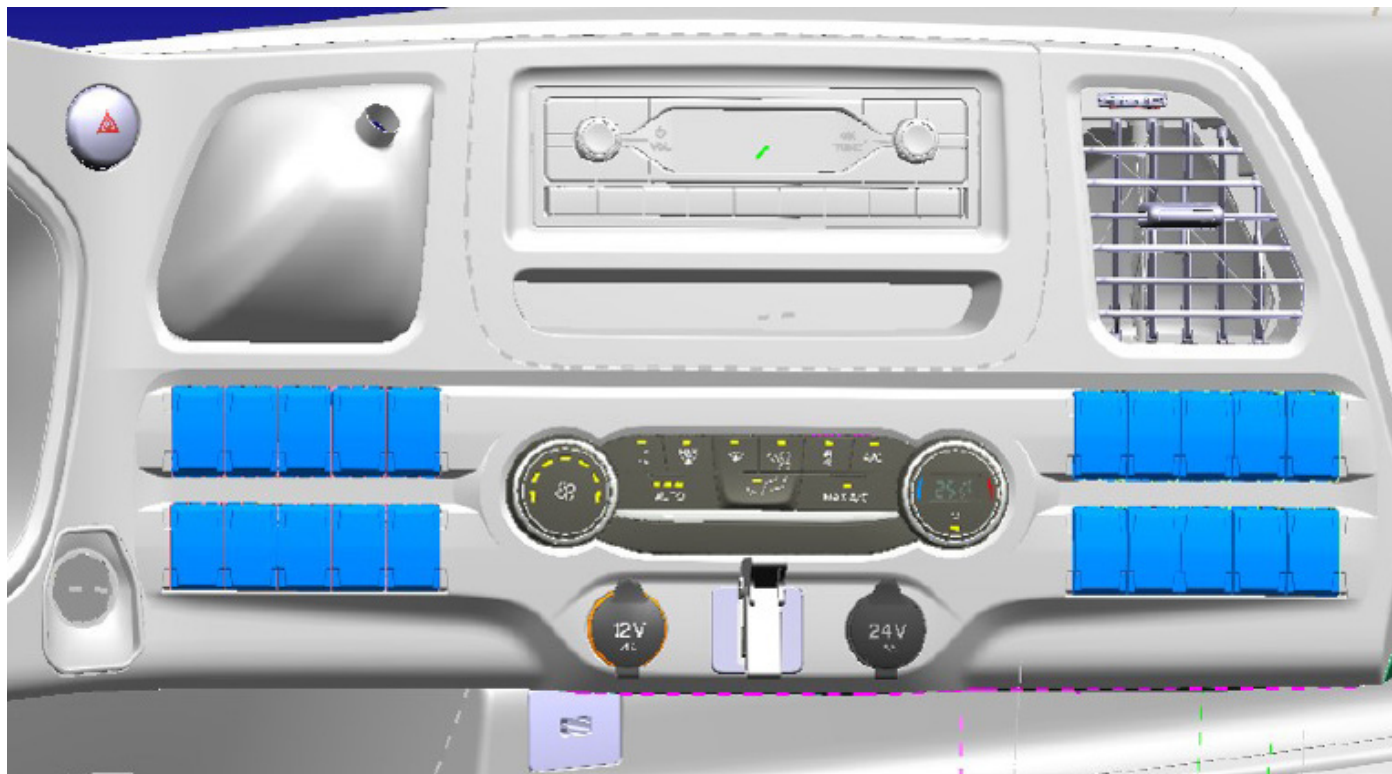

# CONTROLS AND INDICATORS

## Control Buttons

3























FIGURE	SYMBOL	DESCRIPTION
1		EMPTY
2		TRAILER BRAKE
1		EMPTY
3		TIPPER LIFTING
4		AUXILIARY HEATER /TWO OPTIONS
5		RESERVE BUTTON I
6		RESERVE BUTTON II
7		STEERING WHEEL STIFFNESS ADJUSTMENT KNOB
8		TRAILER AXLE LIFTING
9		EMERGENCY BRAKING SYSTEM
10		LANE DEPARTURE WARNING SYSTEM
11		MANOEUVRE MODE SELECTION
12		DRIVING MODE SELECTION

FIGURE	SYMBOL	DESCRIPTION
12		TRANSMISSION POWER MODE SELECTION
13		ASR CANCEL/ACTIVE
14		DIFFERENTIAL LOCK
15		HILL LAUNCH ASSIST
16		AUTOMATIC HYBRID BRAKE
17		DIESEL PARTICULATE CLEANING ACTIVATE
17		DIESEL PARTICULATE CLEANING DEACTIVATED
18		MAP LAMP
18		MAP LAMP
19		WARNING SWITCH HAZARD FLASHER
20		HANDBRAKE
21	<b>STOP</b>	ELECTRICAL CIRCUIT BREAKER

# CONTROLS AND INDICATORS

## Control Buttons

3

### Bed control buttons



FIGURE	SYMBOL	DESCRIPTION
1		ALL LAMPS OFF
*1		BED COMPARTMENT LAMPS ON/OFF
2		AMBIENCE LAMP ON/OFF
*2		FRONT LAMP AND CENTRAL LAMPS ON/OFF
3		RADIO VOLUME UP/DOWN
4		AUXILIARY HEATER ON/OFF
5		TROOF ON/OFF

### Lower left control panel control buttons



FIGURE	SYMBOL	DESCRIPTION
1		LIGHTING WORKING LAMP
2		EMPTY
3		LOW LINER SWITCH
3		LOW LINER SWITCH

**NOTE:** If your vehicle is equipped with touchscreen multimedia, you can use the buttons described on page 43 via the touchscreen.

### Upper panel control buttons













FIGURE	SYMBOL	DESCRIPTION
1		EMPTY
2		AIR HORN
3		AMBIENCE LAMP ON/OFF
4		DOOR OPEN WARNING
5		ROOF ON/OFF
6		SUNSHADE
7		DOME LAMP

If the buttons marked with \* are pressed for more than 1.2 seconds, a continuous illumination from a low value to a high value can be achieved.

# CONTROLS AND INDICATORS

## Control Buttons

**NOTE:** If your vehicle is equipped with touchscreen multimedia, you can use the following buttons on the touchscreen.

SYMBOL	DESCRIPTION
	MANEUVER MODE SELECTION
	TRANSMISSION POWER MODE SELECTION
	OSCILLATION POWER MODE SELECTION
	DIESEL PARTICLE CLEANING ACTIVATED
	DIESEL PARTICLE CLEANING DEACTIVATED
	AUXILIARY HEATER ON/OFF
	CENTER LAMPS READING LAMP ON/OFF (RIGHT) BUTTON
	READING OF CENTER LAMPS LAMP ON/OFF (LEFT) BUTTON
	FRONT LAMPS AND CENTER LAMPS ON/OFF
	AMBIENT LIGHT ON/OFF
	DOOR OPEN WARNING

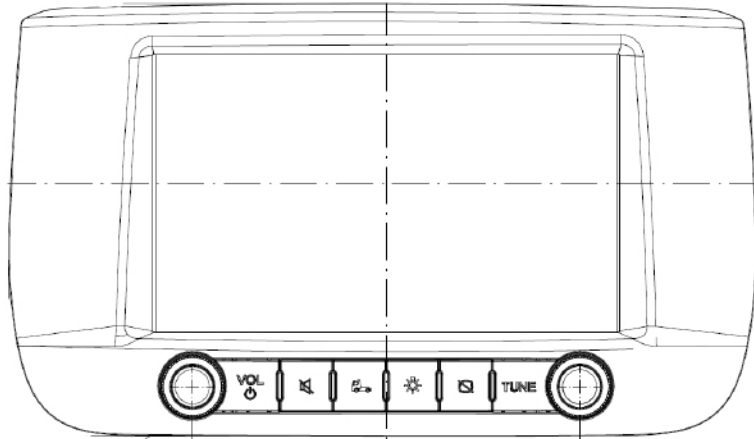

# CONTROLS AND INDICATORS

## Control Buttons

3

### Control buttons

#### Audio and volume control buttons

Select the source you want to use for audio. With the controls on the steering wheel you can operate the following functions in the music and sound system:

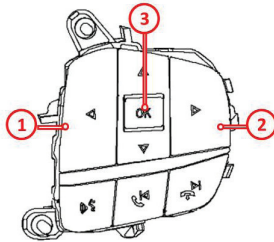

**1-** Activates the voice command function of your phone if a phone is connected to your vehicle.

This system allows you to control many features using voice command. And this allows you to keep your hands on the steering wheel and focus on the road.

**2-** Seeking frequencies forward or next. 

**2-** Rejects the call 

**3-** Seeking frequencies backward or previous 

**3-** Accepts the call 

By pressing the Call, Next or Previous buttons:

- You may tune the radio to the next or previous stored preset station
- You may play the next or the previous track.

Press and hold the seek button to:

- tune the radio to the previous or next station.
- seek through a track.

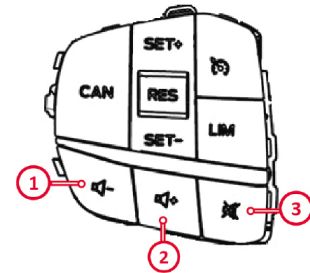

- 1- Volume down
- 2- Volume up
- 3- Mute and unmute



# CONTROLS AND INDICATORS

## Control Buttons

### Axle raising button

Axle raising function may be activated by pressing the button below. Anti-skid mechanism and instantaneous raising function are activated and the axle is raised when the button is pressed for 3 (three) to 5 (five) seconds. Automatic axle raising function is deactivated and the axle is lowered when the button is pressed for 5 (five) seconds or more. Tag axle is lowered continuously when the trailer is empty or partially loaded.

**Note:** Axle raising function may only be activated when the trailer is connected to the tractor and ignition is switched on.

**Note:** Axle raising function may not be activated if the trailer is loaded when the speed of the tractor is above 30km/h.

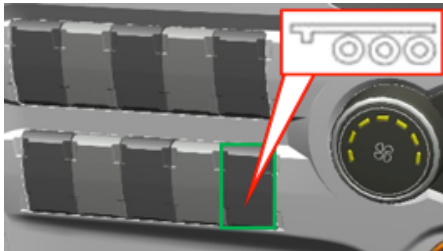

# MULTIMEDIA

## Audio Unit

3

### Audio Unit (Model-1)

Turning the audio unit on and off.

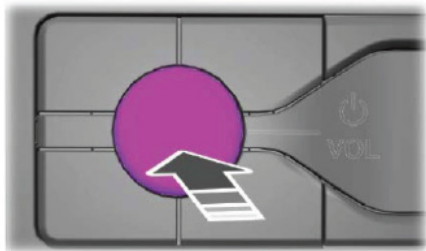

Setting Volume

Navigating in the Menu Options

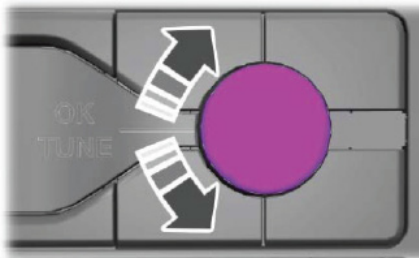

Selecting a Menu Option

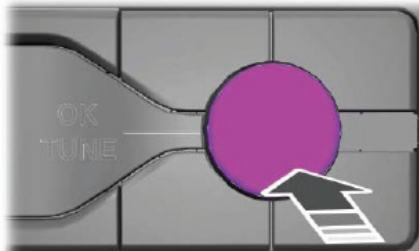
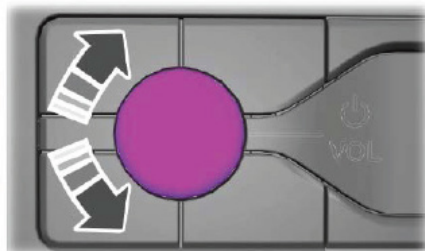

### Returning to Previous Screen



Press the button to return to the previous menu.

### Selecting Radio



Press the button to select radio mode. Press the button again to display available radio sources.

Press the button continuously or rotate the right-hand knob menu to switch between available radio sources.

Apps like Siri or Svoice on the phones shall be launched when you press the push-to-talk button on the steering wheel after connecting the phone and the radio with a USB cable.

### Changing the Radio Station

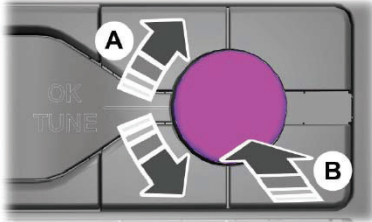

#### A Automatic or manual setting B Setting a station name.

**Note:** You may switch between automatic and manual setting with the knob using system settings.

**Note:** You may switch radio stations with the scanning buttons.

**Note:** You may switch radio stations with the preset number buttons.

### Selecting Media



Press the button to select media mode. Press the button continuously or rotate the right-hand knob menu to switch between available media sources.

### Forward Scan and Next Track Button



Press the button to select the next indexed frequency (in radio mode) or the next track (in USB or BT mode).

### Backward Scan and Previous Track Button



Press the button to select the previous indexed frequency (in radio mode) or the previous track (in USB or BT mode).

### Pausing or Playing Media



Press the button to mute the signal in radio mode. Press the switch again to turn the volume of the signal on.

Press the button to pause the track playing in media mode. Press the button again to resume playing.

### System Settings



### Sound Adjustments

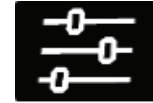

Press the button to adjust volume settings. You may also activate adaptive or speed compensated volume and adjust its precision.

### Using Mobile Phones



You may make a call using the last calls list or from the persons list or dial a number.

# MULTIMEDIA

## Audio Unit

3

### Audio Unit (Model-2) Turning the audio unit on and Off.

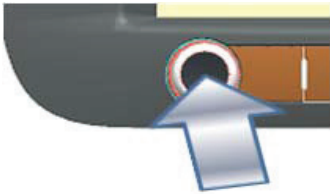

Radio is turned on when you press shortly while the ignition is on. Audio system is turned on/off when you press shortly while the radio is on. This is displayed when you press for a short time while you are in the Audio system menu.

Navigation applications available in the Weblink or Carplay functions in the radio may not be suitable for heavy commercial vehicles. Therefore, you shall prefer the navigation program designed for heavy commercial vehicles on the main menu for navigation purposes.

No audio transfer is available via cable on the Weblink application connected with USB. Connection shall be established via Bluetooth to ensure that audio transfer is available through the speakers of the vehicle in this application.”

### Setting Volume



Rotate the knob to increase/decrease volume.

### Navigating in the Menu Options



Rotate the knob to change the frequency with increments of 0.05MHz.

### Selecting a Menu Option

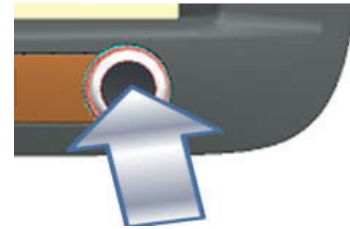

Press the button to stop automatic scan feature.

### Lighting Menu



Press the button to access the lighting buttons controlled from the touch screen.

### Features Menu



Press the button to access the control buttons controlled from the touchscreen.

### Mute Button



Press the button to mute the source. Press the button again to turn the volume of the source on.

### Screen On/Off Button



Press this button to turn the screen on or off.

### Main Page (Software Button)



Press this button to switch to the main page screen.

### Audio System Menu (Software Button)



Press the button to select audio system mode.

### Using Mobile Phone (Software Button)



You may make a call using the last calls list or from the persons list or dial a number.

### NAVIGATION SYSTEM (Software Button)



Press the button to open the Navigation system application.

### Mobile Applications (Software Button)



Press the button to access Android Auto and Carplay applications manually.

### System Settings (Software Button)



Press the button to adjust the volume settings, radio settings, screen settings and to access the camera.

# MULTIMEDIA

## Audio Unit

3

### Radio Station Setting

#### Search (Alternative 1)

1. Press and hold the forward or rearward search button and then release the button. The system stops at the first station it finds in the direction you have chosen. Or press the forward or rearward search button, you may select one from the automatically found stations.

#### Automatic Station Search (Alternative 2)

This feature displays all available stations in a list.

1. Press the Refresh button in the stations menu.
2. Automatically found stations shall be listed. You may select the stations from this list.

#### Manual Search (Alternative 3)

1. Turn TUNE knob to the left or right.

### Stored Station Buttons

This feature allows you to store one of your favourite stations to any of the preset station buttons.

1. Select a station.
  2. Press and hold one of the preset buttons.
- After storing the station, just press the button to select the preset station.

**Note:** If you get out of the coverage area of the station, the stored stations on the preset station buttons may not always work. In such a case, the system is muted. This may cause changes on the available radio stations.

### USB PORT



#### WARNING

Driving while distracted can result in loss of the vehicle control, a crash and injuries. We strongly recommend that you use extreme caution when using any device that may take your focus off the road. Your most important responsibility is the safe operation of your vehicle. We recommend you to use voice-controlled systems whenever possible, instead of devices that require the use of your hands while driving. Make sure you are aware of all applicable local laws that may affect the use of electronic devices while driving.



USB port allows connection of media players, flash drives and recharging of such devices.

**Note:** We recommend you to use USB-IF approved cables and adaptors only. Cables and adaptors that are not approved may not work.

**Note:** Data transfer feature is not available in the USB port on your vehicle.

**Note:** The system supports many of the USB devices or media players, including iOS and Android devices.

### Playing Music from a USB Device or a Media Player

Plug your device to a USB port. Select Sources. Select USB.

**Note:** System shall perform indexing before playing your music.

### Searching for a Track on a USB device or a Media Player

Select Browse. Select a track.

**Note:** Select the cover image to view the information on the current track.

### Bluetooth Connection

#### Initial Pairing of your Mobile Phone

Ensure that your mobile phone is available for search. Refer to the user manual of your mobile phone.

1. Select Connect a Phone from the main menu.
2. Select your vehicle from the mobile phone.

**Note:** A number is displayed on your phone and on the touch screen.

3. Confirm that the number displayed on your phone matches with the number on the touch screen.

# MULTIMEDIA

## Audio Unit

3

**Note:** Touch screen indicates that you have successfully paired your phone.  
4. Allow downloading of the contacts from your mobile phone when you are prompted.

**Note:** Bluetooth connection and its features may only be used properly on mobile phones that are equipped with Bluetooth feature and that support the system.

### Using your Mobile Phone

#### Last Calls List

View and select an entry in the previous calls list.

#### Contacts

View a smart search method to search between your contacts.

#### Phone Keypad

Enter and call a number using the phone keypad.

#### Phone Settings

Manage your contacts.

Change Device View the list of paired and connected devices that you may choose from.

#### Apple CarPlay

1. Plug your device to a USB port.
2. Follow the instructions on the touch screen.
3. The system displays the applications offered by CarPlay.

**Note:** You may not use some features of the system while using Apple CarPlay.

#### Android Auto

1. Plug your device to a USB port.
2. Follow the instructions on the touch screen.
3. The system displays the applications offered by Android Auto.

**Note:** You may not use some features of the system while using Android Auto.



# CONTROLS AND INDICATORS

## Multi-functional Handles

### Multi-functional handle (left)

It is placed on the left side of the steering.



1. High Beam (Continuous)  
Push the lever forward to turn the main beams on.  
Push the lever forward again or pull towards you to turn the main beams off.
2. High Beam (Flasher)  
To open the selector, pull the lever slightly towards you and release.
3. Right/Left Turn Signal  
Push the lever up or down to use the turn signal lamps.
4. Windshield Water Spray  
Press the button to activate the washers and spray water to the windshield.
5. Wipers
6. Wiper position

# CONTROLS AND INDICATORS

## Multi-functional Handles

3

### Multi-functional handle (right)



This handle has the following functions:

- Gear
- Engine brake and retarder

### On vehicles without retarder



1. Engine brake
2. Engine brake range
3. Gear selection
4. Upshifting/downshifting
5. Automatic / Manual gear selection

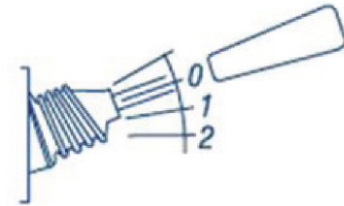

	<b>Engine Brake</b>
1. Range	Reduced Brake Power
2. Range	High Brake Power

# CONTROLS AND INDICATORS

## Multi-functional Handles

### Vehicles with Retarder



1. Retarder
2. Retarder Range
3. Gear selection
4. Upshifting/downshifting
5. Automatic / Manual gear selection

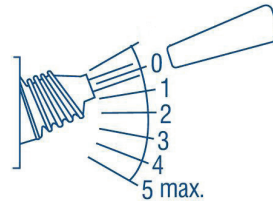

	Engine Brake	Retarder
Retarder 1	50% Max. Brake Power	20% Max. Brake Power
Retarder 2	50% Max. Brake Power	40% Max. Brake Power
Retarder 3	100% Max. Brake Power	60% Max. Brake Power
Retarder 4	100% Max. Brake Power	80% Max. Brake Power
Retarder 5	100% Max. Brake Power	100% Max. Brake Power

### Activation of the gradual continuous braking operations

Bring the gradual braking lever from 1 to max. position.  
 The vehicle is continually decelerated according to the selected position.  
 Position 1 = low deceleration  
 Max. Position = more deceleration.

### Deactivation of the gradual continuous braking operations

- Gradual braking lever:
- OFF position

# CONTROLS AND INDICATORS

## Tachograph

3

### Insert paper roll

▶ Press the unlocking surface on the printer panel, the printer drawer opens.

▶ Pull the printer drawer out of the DTCO.

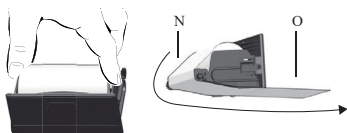

▶ Insert new paper roll according to the illustration and guide it via the pulley (1).

☞ Make sure that the paper roll does not become jammed in the printer drawer and the start of the paper (1) extends beyond the edge of the printer drawer!

- ▶ Push printer drawer into the printer compartment until it engages.
- ▶ The printer is ready for operation.
- ▶ You can start a printout.

### Messages

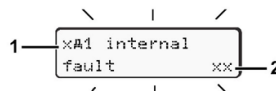

(1) Pictogram and plain text of the message

! = Event, example [!00 driving without card]

x = Fault, example [x1 sensor fault]

! = Driving time warning [!01 break! Operational note, example

(2) Error code

For further messages and measures refer to the operating instructions.

### Acknowledge message:

- ▶ Press key **OK** 2 times, the message disappears.

### Times of the driver card(s)

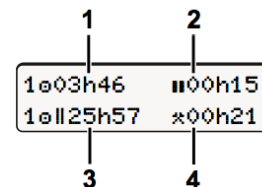

- (1) Driving time "0" since a valid break time.
- (2) Valid break time "00" in accordance with regulation (EU) no. 561/2006.
- (3) Driving time over two weeks "011".
- (4) Duration of the set activity.

☞ These brief instructions shall not, under any circumstances, be regarded as a substitute for the exhaustive operating instructions for the DTCO 1381 prescribed by EU Regulation (EEC) no. 3821/85, Annex I B.

# CONTROLS AND INDICATORS

## Tachograph

### Calling up menu functions

Possible only when the vehicle is stationary!

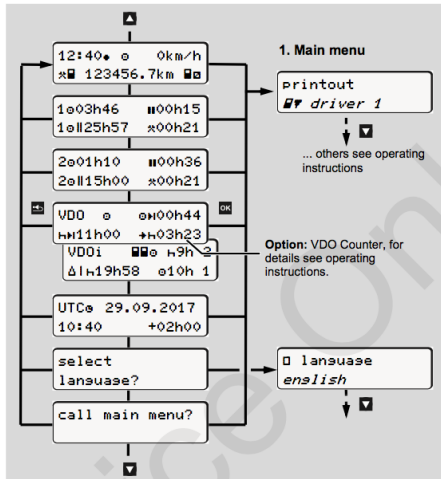

- ▶ Use the buttons **▲/▼** to select the desired display.
- ▶ Use button **OK** to call up the main menu.

- ▶ Use **/** to select the listed **▲/▼** functions step by step.

### Print daily value:

- ▶ [printout **☐** driver 1] ... [24h **▼** day] ... [25.10.2017] ... [printout in UTC yes/no]

### Enter "Out of scope" beginning / end:

- ▶ [entry **A** vehicle] ... [OUT+ begin] or [OUT end]

### Enter Beginning of ferry / train:

- ▶ [entry **A** vehicle] ... [OUT+ begin] or [OUT end]

- ▶ Set the current activity.

### Set Local time:

- [entry **A** vehicle] ... [☐ local time] ...

- ▶ Set Local time in steps of ± 30minutes.

# CONTROLS AND INDICATORS

## Tachograph

3

### Brief instructions Driver

DTCO® 1381 - Release 3.0

A2C13870700/41024284 OPM 000 AA

BA00.1381.30 500 102



www.fleet.vdo.com



### Operational elements

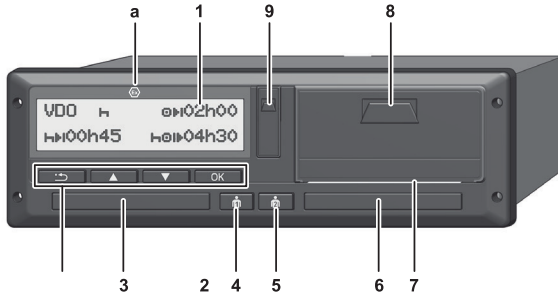

(1) Display

(2) Menu buttons

▲/▼ Select function / selection

OK Confirm function / selection

Exit, abort menu

(3) Card slot 1

(4) Combination key Driver 1

Setting of activities and ejection of the driver card

(5) Combination key Driver 2

Setting of activities and ejection of the driver card

(6) Card slot 2

(7) Cutting edge

(8) Printer drawer

(9) Download interface

(a) Symbol for ADR variant

### Standard display(s) during trip

► Press any menu key, change to the desired display.

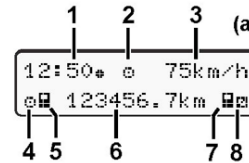

(1) Time (with "\*" = set local time)

(2) "Operational mode"

(3) Speed

(4) Activity, driver 1

(5) Card symbol, driver 1

(6) Toplam kilometre

(7) Card symbol, driver 2

(8) Activity, driver 2

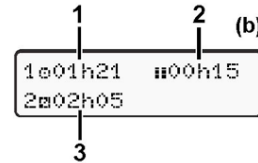

(1) Driving time "a" Driver 1 since a valid break time.

(2) Valid break time "u", in accordance with regulation (EU) no. 561/2006.

(3) Time of driver 2; availability time "b".

The option "VDO Counter" allows another standard display; for details refer to the operating instructions.

# CONTROLS AND INDICATORS

## Tachograph

3

### Insert driver card / Manual entries

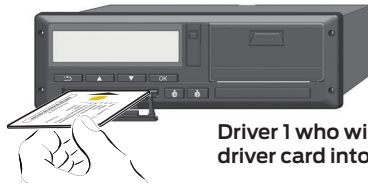

Driver 1 who will drive the vehicle inserts his driver card into slot 1.

- ▶ If necessary, switch on the ignition in case of the ADR variants.
- ▶ Keep the combination key Driver 1 for more than 2 seconds.
- ▶ Set, acknowledge day, hours, minutes. Set, acknowledge the next activity.  
The card slot is opened.
- ▶ Open the card slot cover.
- ▶ Insert driver card into the card slot.
- ▶ Close card slot and push it in.
- ▶ Follow the menu guidance.

**Always keep the card shafts closed – except for the insertion or removal of your driver card!**

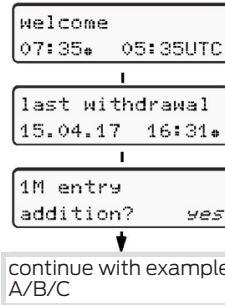

The set local time "07:35\*" and the UTC time "05:35UTC" appear (time offset = 2 hours).

The date and time of the most recent card withdrawal will be displayed in local time (symbol "\*").

**Please ensure the continuous recording of the activities on your driver card!**

Make manual entries with "Yes".

If you **do not want** to add any activities/rest periods, select "No".

# CONTROLS AND INDICATORS

## Tachograph

3

Example A:

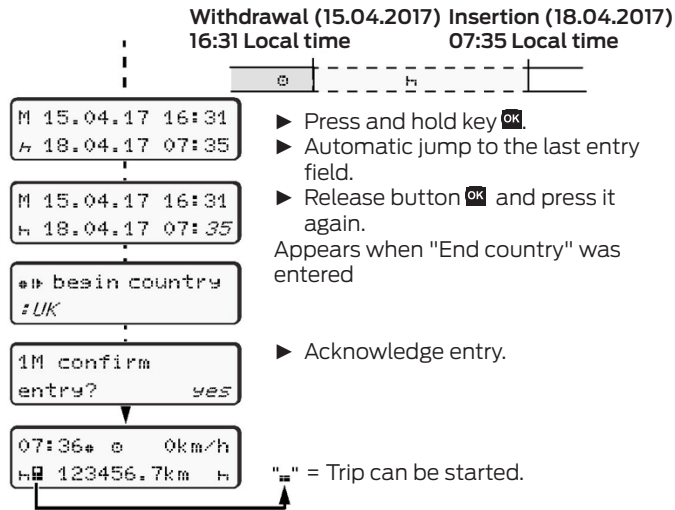

These brief instructions shall not, under any circumstances, be regarded as a substitute for the exhaustive operating instructions for the DTCO 1381 prescribed by EU Regulation (EEC) no. 3821/85, Annex I B.

Example B:

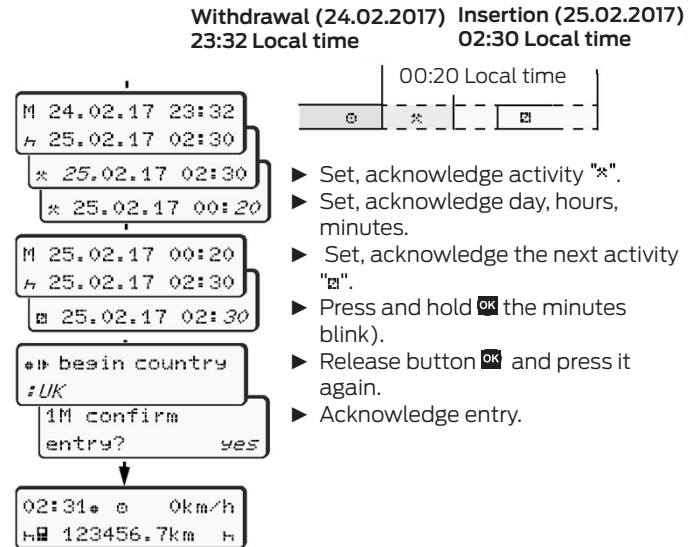



# CONTROLS AND INDICATORS

## Tachograph

### Example C:

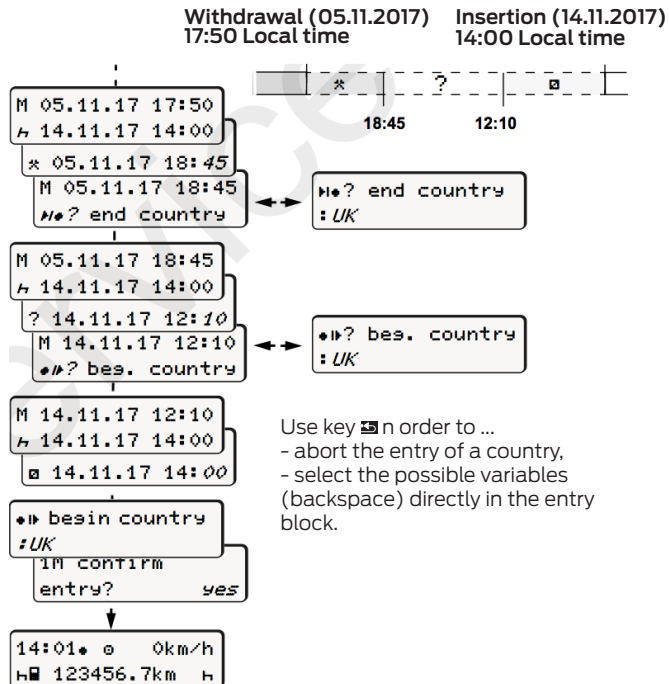

### Withdrawing driver card

- ▶ If necessary, switch on the ignition in case of the ADR variants.
- ▶ Press the corresponding combination button for more than 2 seconds. Follow the menu guidance.

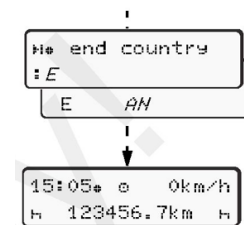

- ▶ Select, acknowledge the country.
- ▶ If present, select region, acknowledge.
- ▶ With button **#** you can abort the entry of a country if you, for example, want to continue your work shift.
- ▶ The card shaft is opened to withdraw the driver card.
- ▶ Withdraw driver card.
- ▶ Close card slot and push it in.

# CONTROLS AND INDICATORS

## Tachograph

3

### Setting activities

- ◻ = Driving time (automatic when driving)
  - ✱ = All other working times (Automatically when the vehicle is stopped, for driver 1)
  - ◻ = Availability: Waiting times, co-driver time, sleeper-cab time during the trip (Automatically when driving or when the vehicle is stopped, for driver 2)
  - h = Break times and rest periods
- ▶ **Driver1:** Press the combination key Driver1 repeatedly for a short time until the desired activity (h ◻ ✱) is shown in the display.
- ▶ **Driver 2:** Press the combination key Driver 2 repeatedly for a short time until the desired activity (h ◻ ✱) is shown in the display.

At the end of a shift or during a break, always set activity "h"!

### Automatic setting after ignition on/off (option):

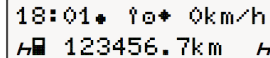

18:01 100 km/h  
h 123456.7 km h

Signalled by flashing of the activity or activities for approx. 5 seconds in the standard display (a). Then, the previous display will appear again.

- ▶ As required, change the activity accordingly!

Symbol "✱" after ignition off means: IMS function (Independent Motion Signal) available.

Symbol "h" after ignition off means: The recording of position and vehicle data is switched on.

# CONTROLS AND INDICATORS

## Tachograph Simulator Unit

3

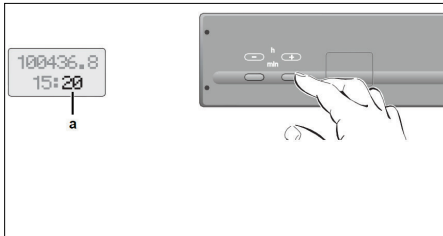
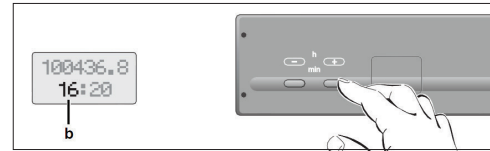
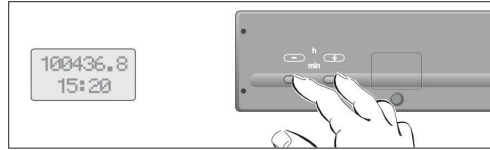
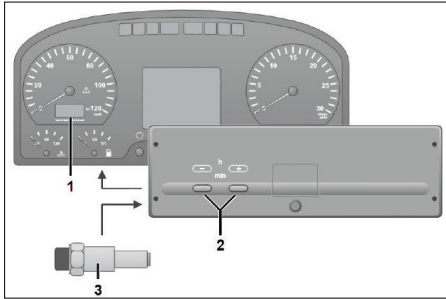

# OPERATION

4

# OPERATION

## Opening and closing of the vehicle

### Switch

2 keys are supplied with the vehicle, one for your use, and one as a spare.



- Door lock
- Ignition

### Spare switch



- Fuel tank
- Urea tank



### WARNING

Ignition key has an immobilizer feature against vehicle theft. New keys shall be programmed by Ford Otosan authorized dealerships.

### Door Control



You can lock and unlock doors with the remote control.

- 1- Locking button
- 2- Unlocking button

Central locks are opened when the open button of the control is pressed. They are closed when the close button is pressed. If the direction indicators flash twice: Doors are locked. When any of the doors are not closed for any reason (mechanical or electrical), error is detected and both doors are brought to open position.

However, central locking function on manual opening and closing is temporarily disabled until central locks are brought to the same position. Error is resolved when the doors are closed fully.



### WARNING

New remote controls shall be introduced to the vehicle when a new control is purchased. Please visit a Ford authorized dealer for the introduction of the controls. Doors are locked again if the central lock is opened with remote control and doors are not opened physically. Doors are locked automatically when vehicle speed exceeds 10 km/h.



### WARNING

Module switches to protection mode if opening and closing operation is performed successively for 8 times in central locks both manually and via the remote control. System stops manual operation and operations by the control for 7 seconds. It performs the operations received after that 7 seconds later. This condition ends if you wait for 1 minute without any intervention.

# OPERATION

## Opening and closing of the vehicle

4

### Opening the Window with Remote Control

Doors are unlocked and windows are lowered to the minimum level when opening button on the remote control is pressed for more than 3 seconds. This feature also includes the opening of sunroof with the windows on vehicles with power roof.

### Closing the Window with Remote Control

Doors are locked and windows are closed automatically when closing button on the remote control is pressed for more than 3 seconds. This feature also includes the closing of sunroof after the doors on vehicles with power roof. Window closing operation is not performed if the "Quick Window Closing" feature is not set on the windows.

### Battery Replacement

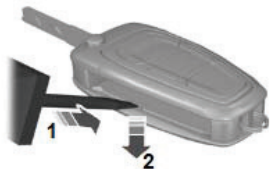

Make sure that you dispose of old batteries in an environmentally friendly way. Seek advice from your local authority regarding recycling.

1. Insert a suitable tool, e.g. a screwdriver in the position shown and gently push the clip.
2. Press the clip down to release the battery cover.



3. Remove the battery cover.

**Note:** Do not touch the battery terminals or the printed circuit board with the screwdriver.



4. Turn the remote control over to remove the battery.
5. Install a new battery with the + terminal facing upwards.
6. Install the battery cover back.

**Note:** Do not remove the grease on the battery terminals or on the rear surface of the circuit board.

**Note:** You do not need to reprogram the remote control after replacing its battery; remote control shall operate normally.

# OPERATION

## Opening and closing of the vehicle

### Opening and closing the external door with key

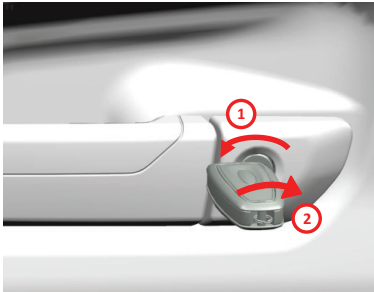

Turn the key clockwise to lock the door with the key. (2)  
Turn the key counter-clockwise to unlock the door with the key. (1st

### Outer Handle

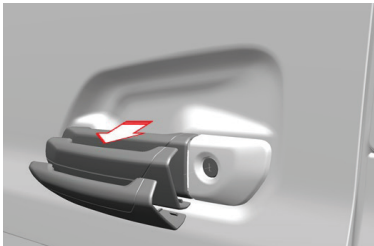

Pull the latch towards you to open the door.

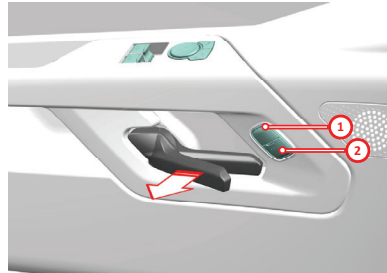

Pull the latch towards you to open the door from the inside.  
Press button no. (2) to lock the doors from inside and press button no. (1) to unlock them.

### Getting In and Off the Vehicle

Use the 3 points principle while getting in and out of the vehicle. Do not hold the steering wheel while getting in the vehicle.



### WARNING

Handles are designed so that the user shall face the vehicle while getting on/off the vehicle. Do not attempt to get on/off the vehicle facing outwards.

### Don't:

Do not try to get in the vehicle by holding the steering wheel instead of the handle. Do not get off the vehicle facing outwards. Do not get off the vehicle by jumping from the steps.

Do not step over the door. Do not use the door as a support while getting in and out of the vehicle, use the climbing pipe as a support. Do not pull or push the door from interior door opening handle. Use interior door opening handle.

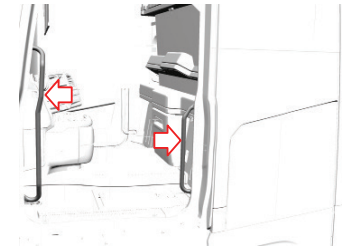

Do not hold handles for purposes other than getting on/off the vehicle to prevent your hand from being caught while the door is closed. Prefer the handles on the door while the vehicle is moving.

# OPERATION

## Opening and closing of the vehicle

### Windows

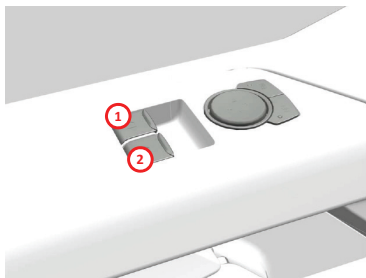

- 1- Driver side window opening and closing button  
2- Passenger side window opening and closing button

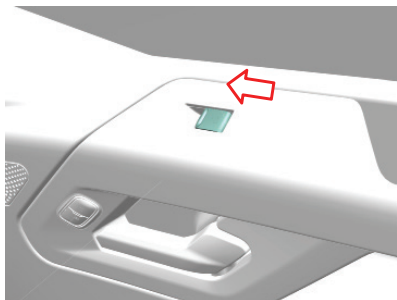

### Window opening and closing

Window moves to opening or closing direction while the opening/closing buttons are pressed. Power provided to the motors is turned off automatically when the window reaches uppermost or lowermost position.

**Buttons are active while the ignition is on. If the door is not opened after the ignition is switched off, the buttons will remain active for 10 minutes. This period is 1 minute when the battery level is critical. Buttons do not function until the ignition is switched on after this period.**

### Quick Window Raising

Window raising button has two stages. Window is closed automatically when the button is switched to the second stage. Windows are returned for 10-15 cm if a jamming condition is detected while closing.

### Quick Window Lowering

Window lowering button has two stages. Window is opened automatically when the button is pressed with the second stage.



### CAUTION

If the window is jammed two times in a row while quick closing, window quick raising feature is deactivated.

To re-activate the quick raising feature:

1. When the window is in the middle level, the switch on the window is to be held down and the window will be lowered completely. Continue to press the switch for 3 seconds while the window glass is at the bottom position.
2. Press and hold the switch on the window to raise the window completely. Continue to press the switch for 3 seconds while the window glass is at the top position.
3. Finally, press and hold the switch and lower the window completely to define the window calibration for the lowering & raising function of the automatic window.
4. This operation should be performed separately for both windows.
5. If a jam occurs in the window 2 times (e.g., when the driver's arm gets stuck), the calibration is disrupted and should be done again.



# OPERATION

## Opening and closing of the vehicle

### Opening/closing the front hood

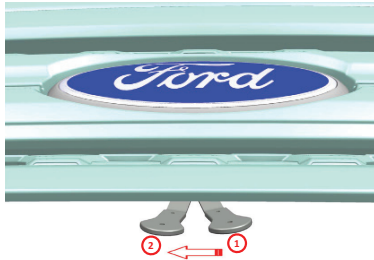

#### To open:

Bring the opening lever under the hood from position (1) to position (2) as shown with an arrow. Raise the hood slightly, pistons shall open the cover.



#### To close:

- Pull the hood from open position by the strap.
- To latch the hood, push from the marked side points.



#### CAUTION

Make sure the hood is fully latched.



#### WARNING

Pull/push the hood from center only for opening and closing operations.  
Do not push the hood at center area for locking operations.

#### Toolbox

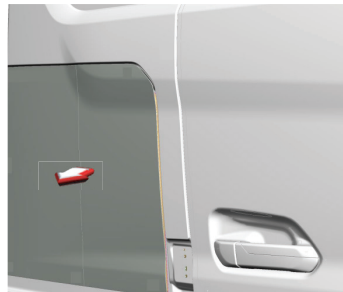

Toolbox is located behind the driver and passenger doors as shown in the figure.



You may open it by pulling the ring on the side of the driver and passenger seats while the door is open.

**Note:** When the toolbox is opened for 90 degrees, it shall be kept open at 90 degrees thanks to the tensioner, it may be closed when it is pulled with a certain force.

# OPERATION

## Cab Ventilation

### Power Roof Flap



Power roof moves to opening or closing direction while the opening/closing buttons are pressed. Operation is stopped automatically when the power roof reaches uppermost or lowermost position. Buttons are active while the ignition is on. Power roof is closed automatically when the control switch is pressed once for a short period while it is open. Power roof is opened automatically when the control switch is pressed once for a short period while it is closed.

Power roof is controlled by a control switch located on the upper panel.

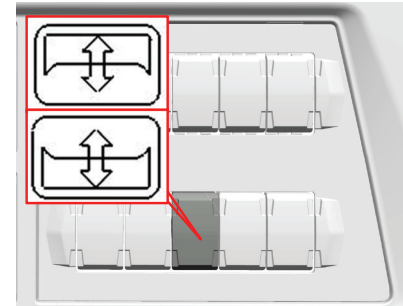

# OPERATION

## Seats and Beds

### Seats – Driver's Seat

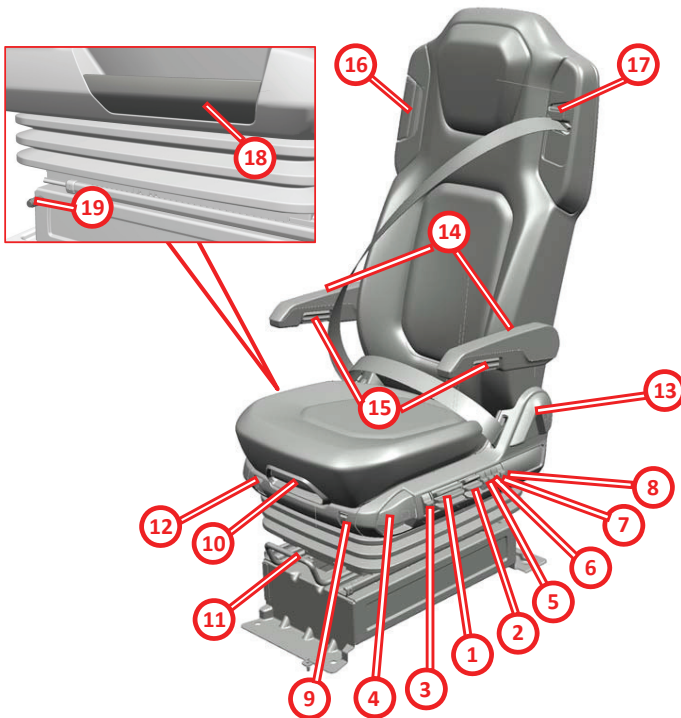

1	Height adjustment
2	Shock absorber adjustment
3	Fast lowering
4	Seat inclination adjustment
5	Side support adjustment
6	Lower lumbar support adjustment
7	Upper lumbar support adjustment
8	Backrest inclination adjustment
9	Heater
10	Cushion forward/backward adjustment
11	Seat forward/back adjustment
12	Forward-backward stretching
13	Back angle adjustment
14	Armrests
15	Armrest inclination adjustment
16	Quick back tilting adjustment
17	Seat belt height adjustment
18	Side pocket
19	Air outlet

# OPERATION

## Seats and Beds

### Seats – Passenger Seat

4



1	Height adjustment
2	Seat forward/back adjustment
3	Back angle adjustment
4	Armrests
5	Armrest inclination adjustment
6	Quick back tilting adjustment

The optional air passenger seat has the same use as the driver's seat on the previous page.  
Driver's Seat and Air passenger seat max. weight capacity is 120 kg.

### Fast lowering

Seat may be lowered to the bottom position by moving the button down. Seat shall release all air when the button is moved down.  
Seat may be returned to the last stored height level by moving the button up.



### CAUTION

Quick lowering button shall be used while getting on/off the vehicle. It shall not be used otherwise.

### Height adjustment

Height adjustment may be applied in 7 steps. By moving the height adjustment button up or down, you may change the seat height a step up or down.

### Shock absorber adjustment

The absorbing harshness of the seat may be adjusted without any steps between soft and hard using the harshness adjustment button.  
Taking the harshness setting lever to uppermost position provides minimum harshness; and taking it to the bottom position provides maximum harshness.

### Forward-backward stretching

It may be helpful to activate horizontal stretching in some operating conditions. Then, the impacts on the movement direction of the vehicle may be absorbed better.  
ON: Horizontal yield ON  
OFF: Horizontal yield OFF

### Seat forward/back adjustment

Fore and aft adjustment is performed by moving the seat forward or backward while pulling the lock lever. Seat shall be locked with an audible click when the lever is released. Seat may be moved completely forward or backward.

**Do not perform the fore and aft adjustment when the seat is lowered. Seat shall always be lifted for the fore and aft adjustment.**

### Seat inclination adjustment

Pull the button on the left upwards to adjust the seat inclination. Seat may be adjusted to the desired position by applying your weight forward or backward at the same time.



### WARNING

**Risk of accident!  
Do not operate the lock lever while driving.**

# OPERATION

## Seats and Beds

### Cushion forward/backward adjustment

Pull the button in front of the seat upwards to adjust the cushion forward/backward. Desired position may be achieved by pushing the cushion forward or backward at the same time.

### Armrests

Armrests can be raised when required.

### Armrest inclination adjustment

The inclination of armrests on the fore-aft direction may be changed by rotating the wheel.

Inclination of the armrest is increased upwards when the wheel is rotated outwards, and reduced downwards when the wheel is rotated inwards.



### CAUTION

Do not use the armrests to climb up the upper bed.

### Heater

Electrical heaters on the backrest and seat cushion are operated in two steps by pressing the seat heater switch.



### WARNING

It is recommended that persons who cannot feel increasing temperature shall not use the heater function as it shall cause various injuries and health issues.

### Backrest inclination adjustment

Press and hold the button to perform backrest inclination adjustment. Backrest may be adjusted to the desired position by moving it forward or backward at the same time. Release the button again to lock it.

### Lumbar adjustment

By moving the buttons up or down, you may adjust the upper and lower lumbar supports to the person.

Air chambers are filled when the mentioned buttons are moved up, and discharged when the buttons are moved down.

If the back cushion does not continue to inflate when the buttons are moved up, this means that you have reached the maximum setting in lumbar support adjustment.

### Side support adjustment

By moving the button up or down, you may adjust the curve setting of the side cushions to the person.

Air chambers are filled when the mentioned button is moved up, and discharged when the button is moved down.

If the side cushions do not continue to inflate when the button is moved up, this means that you have reached the maximum setting in side support adjustment.

### Back angle adjustment

To adjust the back inclination angle while sitting on the seat, desired position is obtained by pulling the lever on the left of the seat upwards and moving your back forward or backward.

### Quick back tilting adjustment

Move the lever on the inner upper area of the seat clockwise in order to adjust the quick back tilting function.

### Seat belt height adjustment

Height adjustment of the seat belt may be adjusted at 4 levels by moving the belt up or down by pressing and holding the button.

### Maintenance

Dirt may hinder the operation of the driver seat. Keep your seat clean to prevent this!



### CAUTION

**There is a risk of injury if the backrest bounces forward!**



### WARNING

Discharge the air by pressing the rapid lowering button when you are getting off the vehicle. This would increase the service life of the seat mechanism.



### CAUTION

If the seat is used without air charge, this would damage the internal mechanism of the seat and render the seat out of warranty cover. Adjustment of the seat while driving may cause unwanted steering movements and injuries.  
-Adjust the seat when the vehicle is stationary only.  
-Adjust the seat when you are sitting on the seat when there is no one in the setting range of the seat.

### General safety notes

Do not keep cutting, piercing tools or items on the upper and lower beds, on the seat and in the side pocket of the seat so that the items do not cause damage inside the cab when the cab is tilted to the front.

Do not use the seat heating function to dry the seat fabric if it is wet. Do not try to push the seat bellow with your hand as it may cause a risk of injury.

### General cleaning notes

Dirt may hinder the operation of the driver seat. Therefore, apply the required care for cleaning of the seat and keep your seat clean.

Do not try to push the seat bellow with your hand as it may cause a risk of injury. Do not try to remove seat fabric while cleaning the seat. Bedding may be removed for cleaning of the bed. The cleaning instructions on the mattress cover shall be followed.

When cleaning the fabric or the plastics of the seat, the bed and the seat belts, apply the cleaning material to a small area first to test the suitability of the material. Do not use flammable or abrasive cleaning materials.

Do not use high pressure cleaners to clean your seat, bed and the seat belts.

# OPERATION

## Seats and Beds

### Single Bed



There is a foldable compartment at the right end of the lower bed. Pull the handle up to raise the compartment. Pull the handle up to the top and release it to lower the compartment.

### Curtains

There are three curtains on the vehicle, namely the left, right and the center curtains. The left and right curtains shall be installed so that their Velcro parts are placed at the center of the vehicle.

### Upper Bearing

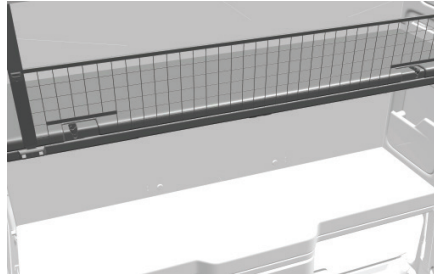

Upper bed is optional. The upper bed be brought to vertical position and locked thanks to the locking mechanisms. Make sure that the upper bed is locked.



### WARNING

Do not carry load or occupants while the vehicle is moving. There is a serious risk of injury for the occupant and the driver as the occupant shall be dashed away.

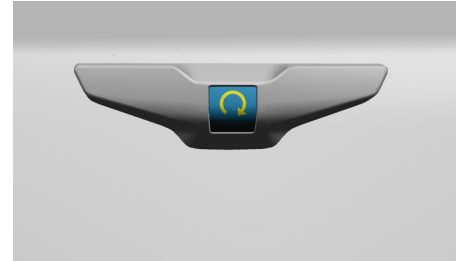

Rotate the lever clockwise to unlock the upper bed. When you shall unlock the upper bed, rotate the lever with one hand to prevent the bed from falling over you while holding the upper bed with your other hand.



### CAUTION

The upper bed netting shall be removed from the belt connections and stored under the bed while driving. Use the handles on the bed to climb to the upper bed. The upper bed shall always be closed during driving. No jackets, weight or objects should be hanged on the upper bearing latch. Otherwise, the bed might open and compromise your safety.



# OPERATION

## In-cab storage compartments



There are 3 covered storage compartments and 2 open storage compartments on the upper console of the windshield. There are open compartments under the covered compartments that allow storage of documents, maps etc.



### WARNING

Do not put heavy items on upper console.

You may load the closed storage compartments of the windshield upper console up to 7.5 kg and load the lower compartment up to 5 kg.



### WARNING

The upper glove compartment covers shall not be opened while the vehicle is moving.

Do not insert piercing, cutting and damaging materials in the compartments of the upper console without a cover.

### Bed top



You may load up to 5 kg on the bed top storage area.

### Center console compartments



These are located in the center console between the driver and the passenger seat. Pull it towards you to open it.

### Shelves

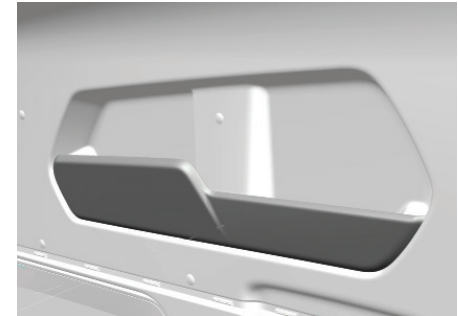

There are 2 shelves on each of the right-hand and left-hand sides of the vehicle. Total weight of the material placed on each shelf shall not exceed 2 kg.

# OPERATION

## In-cab storage compartments

### Centre console



The multifunctional center console, located between the driver's seat and the passenger seat, has map compartments and compartments for cups, pet bottles and other materials.



Do not press on the console. Any damage that may occur if you press on it shall not be covered under warranty.

### Ashtray

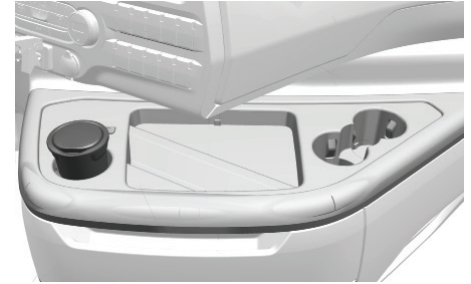

Ashtray is placed on the center of the console. Removable ashtray mechanism provides ease of use in the desired position for the driver.

# OPERATION

## In-cab storage compartments

### Under-bed storage compartments



There is a one compartment drawer in the bed area. Pull it towards you to open it. The capacity of the under-bed storage compartment is 45 kg without a refrigerator and 30 kg with a refrigerator.

### 12 v outlet - 24 V outlet lighter



1-12 V outlet  
2-24 V outlet lighter

#### **CAUTION**

12 V outlet may provide power for devices up to 100W.

"Electricity for devices up to a maximum of 250 W can be supplied from a 24 V power outlet"

#### **CAUTION**

24V lighter/power outlet shall be used for operation of the devices other than the lighter.

#### **CAUTION**

Hold the heated cigar lighter only from its handle. Only use the lighter when the traffic allows you to; otherwise it may distract you and cause an accident.

#### **CAUTION**

Do not hold the cigar lighter element pressed in after it is released.



There is a 12 V outlet on the bed area of your vehicle.

# OPERATION

## Steering Wheel

4



You can adjust the steering angle and height in the most comfortable position for you while driving.

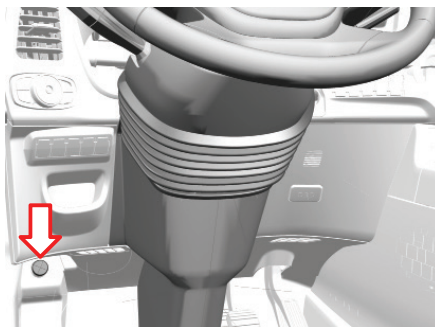

1. Press the button on the lower left side of the steering column with your foot. Thus, power assist to the system shall be activated and setting shall be allowed.
2. Adjust the steering to a proper position by moving it back and forth.
3. Move your foot off without changing the position of the steering wheel.



### CAUTION

A minimum of 7.8 bar air pressure is required to adjust the steering mechanism. If the vehicle air pressure is low, operate the vehicle to fill up to the air tubes.

### Mirrors

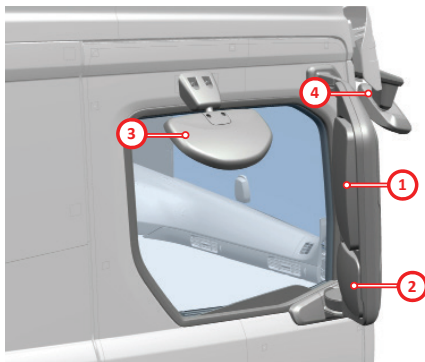

There are 4 different types of mirrors on your vehicle:

- 1- Rear view mirror
- 2- Short-sight rear view mirror
- 3- Kerb mirror
- 4- Front view mirror



### WARNING

Check the settings before operating your vehicle.



Press button no. 1 for the adjustment of the driver's side mirror. Adjust the mirror by moving the arrows forward and backward and left and right, then press button no. 1.

Press button no. 2 for the adjustment of the passenger side mirror. Adjust the mirror by moving the arrows forward and backward and left and right, then press button no. 2.

### Mirror Heater

Mirrors 1 and 2 have heaters. Use the heater for ease of view on winter days.

To activate the heater:  
Press "mirror heater" switch on the A/C panel while the ignition switch is at position 2.



To deactivate the heater: heater shall be deactivated automatically after 10 minutes.

# OPERATION

## Lighting

### Headlamp Switch



Headlamp switch is placed on the console to the left of the steering.

- 0 Headlamps off
- 1 Park lamps and indicator illumination
- 2 Park lamps, indicator lamps and low beam headlamps
- 3 Automatic
- 4 increasing the interior lighting brightness
- 5 decreasing the interior lighting brightness



### CAUTION

Operating park lamps for a long time while the ignition off causes the battery to discharge.

### Headlamp levelling adjustment



Press the button on the headlamp switch to make it come out.  
Rotate the button to set it to the required headlamp levelling adjustment.  
Press the button on the headlamp switch to bring it to the closed position.

Headlamp levelling shall be performed as per the load of the vehicle.



### WARNING

Headlamp levelling shall be adjusted before getting on the road to prevent dazzling the eyes of the drivers of the vehicles in the upcoming traffic in different road conditions.



### CAUTION

The current capacity of the switch may only cover for the available system. Any additions may cause faults on the switch. If an additional illumination system is installed, additional lamps shall have wiring with relay control. Switch shall only control the relay. Audible warning signal is heard when the door is opened when the ignition is off and headlamps are on.

# OPERATION

## Lighting

### Automatic headlights



#### WARNING

Headlamps may not illuminate at all conditions that the field of vision is reduced even if automatic headlamp function is selected on the headlamp switch.

For example, automatic headlamp feature may not switch on the headlamps in case of a fog at daylight. Ensure that your headlamps are switched to automatic or to a suitable on position whenever the field of vision is reduced. Failure to consider this warning may cause a collision.



When the lighting control is on automatic headlamp position, low beam headlamps are turned on automatically when it gets dark on the evening and sensor detects that the ambient lighting level is not adequate.

**Note:** When the lighting control is on automatic headlamp position, headlamps may turn on and off automatically when you are passing under the bridges or viaducts, at low light conditions or under bad weather conditions.

**Note:** Headlamps shall be turned on by the driver in the entrances to tunnels and under some weather conditions.

**Note:** When the lighting control is on automatic headlamp position, low beam headlamps shall be turned in order to turn the fog lamps on.

### Direction Indicator Lever



4

It is placed on the left side of the steering.

Push the lever up or down to use the turn signal lamps. Turn signal illuminates for 6 seconds and turns off automatically when you move the turn signal lever slightly up or down. This would increase attention on the road, especially when you are changing lanes.

High Beam (Flasher)

Flasher is operated by pulling the lever briefly and releasing it (1)

High Beam (Continuous)

Main beams illuminate continuously when the lever is pushed forward.

Push it forward in the same way to turn them off. (2)

# OPERATION

## Lighting

### Front fog lamp



Front fog lamp is placed on the headlamp control panel. Turn this switch on to obtain better visibility and be visible to the incoming traffic in foggy conditions and where the visibility is low. Front fog lamp icon is displayed on the indicator when the switch is pressed.

### Rear fog lamp



Rear fog lamp switch is placed on the headlamp control panel. Turn this switch on to obtain better visibility and be visible to the incoming traffic in foggy conditions and where the visibility is low. Rear fog lamps are illuminated when the low and high beam headlamps are activated only. Rear fog lamp icon is displayed on the indicator when the switch is pressed.



# OPERATION

## Lighting

### Dome Lamps

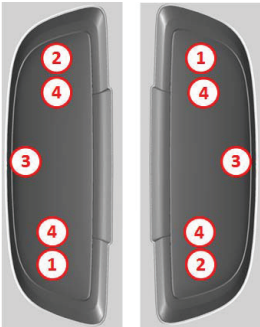

There are 2 dome lamps, one on the driver side and the other on the passenger side, in the dome of the vehicle interior.

### 1 - Reading lamps (Right)

This is controlled by the switch marked with  on the front control panel.

### 2 - Reading lamps (Left)

This is controlled by the switch marked with  on the front control panel.

### 3- Ambience lamps

This is controlled by the switch marked with  on the bed compartment control panel.

### 4- General lighting lamps

This is controlled by the switch marked with  on the bed compartment and upper control panel.

### Front interior lamp



Interior lamp is placed over the windshield on the center area.

This is turned on/off by the switch marked with .

General illumination of the dome and front interior illumination lamps is turned on/off by the status of the door with the switch



on the upper control panel (that it is turned on/off).

### Work Lamp



Work lamp at the exterior of the vehicle is controlled by the switch marked with  on the lower left control panel.

# OPERATION

## Lighting

### Bed compartment lamp

4

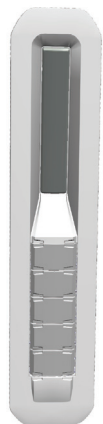

This is controlled by the switch marked with  on the bed compartment control panel.

# OPERATION

## Window Washing and Heating Systems

### Water spray



Press the button shown with an arrow on the left multifunction lever to spray wiper fluid to the windshield. Spraying function shall be stopped when you release the button.

### Windshield Washer Reservoir

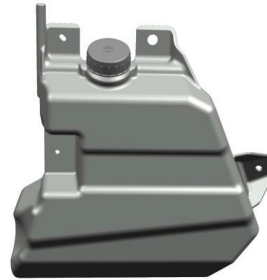

Windshield washer reservoir is placed on the front of your vehicle. You may access it by opening the hood. Add water and cleaning agent regularly before you run out of washer liquid.

### Automatic Wipers

Automatic wiper function uses rain sensor. Sensor is placed on the rear bottom side of windshield. Rain sensor checks humidity level on the windshield and operates the wipers automatically. System adjusts the wiper speed according to the humidity level detected on the windshield by the sensor.



Wiper lever "Automatic wiper" position If your vehicle is equipped with an Automatic Wiper, wipers shall operate automatically as per the amount of rain when you bring the wiper lever to "Automatic Wiper"

position  and select "Rain Sensor" from the settings tab on the instrument panel. Automatic wipers have 2 sensitivity levels.

When sensitivity level 1 selected, they shall activate when a high amount of rain is detected on the windshield. When sensitivity level 2 selected, they shall activate when a lesser amount of rain is detected on the windshield.

# OPERATION

## Window Washing and Heating Systems

4

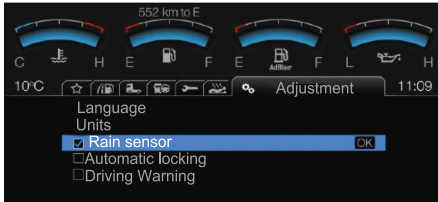

### Instrument panel rain sensor setting

When you bring the wiper lever to another position than the Automatic Wiper position, Automatic Wiper function shall be turned off and wipers shall operate as per your selection.



### CAUTION

Defrost the windshield completely before operating the wipers. Ensure that automatic wiper feature is turned off before having your vehicle washed. Clean the wiper blades if your wipers start to leave traces on the windshield. Install new wiper blades if your wipers continue to leave traces.

If automatic wipers operate more quickly or slowly than you expect in case of rain, select the suitable speed yourself using the lever to prevent being distracted and to see the road better.

Bugs crashing on the area where the rain sensor is placed on the windshield may cause unexpected operation of the wipers. We recommend you to keep the area on around the sensor on the windshield clean.

Water splashing on the windshield when the road is wet, and icing, snow or fog at winter may cause erratic or unexpected operation of automatic wipers or cause the automatic wipers to scatter the dirt and deteriorate the vision.

You may perform the following to keep the windshield clean.

- You may switch to normal or high speed wiping.
- You may turn the automatic wiper feature off.

# OPERATION

## Circuit Breakers

Use the circuit breakers to disconnect the electrical current in your vehicle.

### Vehicles with ADR



An ADR switch shall be available on vehicles that transport flammable, explosive, combustible material. ADR switch cuts all electricity of the vehicle off. There are 2 ADR switches on your vehicle; one is inside the cab, and one is outside. Both switches have the same function. To cut the circuit off, it is adequate to turn off one.

### Using the internal switch

To cut the circuit off; Raise the safety cover and raise the switch.

### To re-activate the electricity supply of the vehicle:

Put the switch down. Close safety cover.

### Using the external switch



### To cut the circuit off

Raise the safety cover and raise the switch.

### To re-activate the electricity supply of the vehicle:

Put the switch down. Close the safety cover.



### CAUTION

Using this switch frequently may damage electronic devices on the vehicle.

When any one of the cab interior and exterior breaker switches is activated, some electrical loads are deactivated within 1 second. After 10 seconds, all electrical connection shall be disconnected.



### CAUTION

Vehicles with ADR carrying fuel oil and dangerous goods shall always be degassed before entering the service.

### Vehicles without ADR

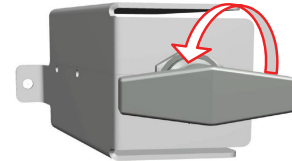

Turn the switch counter-clockwise to cut the circuit off. Turn the switch clockwise to re-activate the electricity supply of the vehicle.



### CAUTION

Use the circuit breaker at least 2 minutes after you have stopped your vehicle. Otherwise, engine electronic control unit (and Denox control unit, if available) may be damaged.



### CAUTION

Disconnect the battery terminals in case of any welding operation on your vehicle.

# OPERATION

## A/C and Heater

### Air conditioning

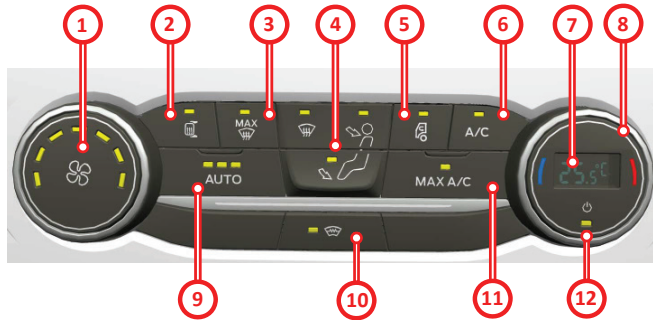

4

**1- Blower speed control:** Adjusts the amount of air to be blown to the interior of the vehicle.

**2- Mirror heater:** Use the heater to ensure ease of view and to defrost and demist the mirror on winter days.  
Note: Do not clean the mirror housing or glass with harsh abrasives, fuel or other petroleum based cleaning products.

**3- MAX Defrost:** Press the button to turn the maximum defrost feature on. Air taken from the outside is blown from the air vents of the windshield, A/C automatically turns on and fan speed is set to maximum level automatically. You may use this setting for demisting and defrosting.

**4- Air distribution direction:** You may use these buttons to take air from windshield, front console and/or footwell vents.

You may ensure blowing of air from these at the same time in various ways.

**Note:** Direct the air to your legs to ensure better comfort under cold conditions. Direct the air to the windshield and to the side windows to prevent misting under cold and humid ambient conditions. Direct the air to your face to ensure better comfort under hot conditions.

**5- Recirculated air:** Press this button to take the air to be blown to the cab either from inside or outside of the vehicle. Air is taken from the inside when the warning light on the button is illuminated. When air is taken from the inside, time required to cool the cab may be reduced and ingress of the unwanted odours outside to the cab are prevented. (When used together with the A/C). Operation of the recirculation mode for a long period in

humid air conditions may cause misting on the windows.

**6- Air-conditioner:** Press the button to turn the A/C function on and off. Use air conditioning with recirculated air to improve cooling performance and efficiency.

**Note:** In some cases (such as maximum defrost), A/C compressor may continue to operate even if the A/C is turned off.

**7- A/C temperature setting indicator screen:** Temperature values set are displayed on the screen.

**8- High and low temperature setting:** You may set the temperature desired in the cab from 15° C and 30° C with intervals of 0.5° C.

# OPERATION

## A/C and Heater

4

### 9- Automatic Conditioning Selection

**button:** Press the button to activate the automatic conditioning function. Set the desired temperature using the high and low temperature setting switch. System adjusts the blower speed, air distribution and the operation of A/C and selects external air or recirculation air in order to cool or heat the vehicle to maintain the desired temperature.

**NOTE:** While AUTO mode is selected in the A/C control unit, AUTO mode shall be deactivated if any key is activated on the control unit. However, the system shall be resumed to be controlled automatically to reach the desired temperature.

### 10 - Heated windshield (if available)

Press the button to defrost and demist the heated windshield.

**Note:** Ensure that the engine is on before switching the heated windshield on. System shall not operate if the battery level is low. And replacing the filter that dries air every 3 or 4 years shall prevent the performance loss of A/C.

**Note 3:** We recommend you to open the windows for a short a period in addition to operating the air conditioner when you get in your vehicle on very hot days. The temperature of the cab shall reach the comfort level in a shorter period in this way.

**11 - MAX A/C** Press the button again to maximize cooling. Air taken from the inside of the cab is blown from the air vents of the front console, A/C automatically turns on and fan speed is set to maximum level automatically.

**12- Power:** Press the button to switch the system on and off. Ingress of external air to your vehicle is prevented when the system is off.

**NOTE 1:** To get a better performance from your vehicle's A/C, turn it on even in winter for 5 minutes every 15 days. It is not required to set the knob to cold position during this usage.

**NOTE 2:** Mist that forms on the windshield in cold weather conditions may be cleaned much more easily if the A/C and hot air is operated for a few minutes. Then turn the A/C off.

The gas type and amount of the gas used in A/C is printed on the sticker. (Adding oil to the A/C compressor is not necessary unless all gas drains from the A/C.

Your vehicle's A/C will not require maintenance under normal conditions. However, we may advise you to remove and clean the fly screen located in front of the radiator periodically to obtain a better efficiency. And replacing the filter that dries air every 3 or 4 years shall prevent the performance

loss of A/C.

**Air Distribution:** Conditioning air is distributed inside the cab with various blowers as per the desired operating conditions.

**Note:** Do not cover the blowers with items such as clothes, etc. Performance of the ventilation inside the cab may be reduced if the blowers are covered with any accessory or equipment.



### Setting the blowers:

Blowers on the driver's side:  
1- Off (1)  
2- On (2)

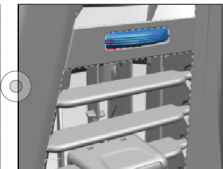
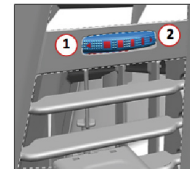

# OPERATION

## A/C and Heater

### Blowers on the passenger side:

- 1- Off (1)
- 2- On (2)

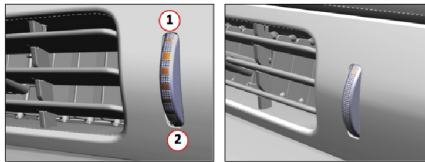

Use the control wheel to take adequate amount of air to the cab. Blowers on the driver and passenger sides have two positions, namely off and on. Air flow may be set as desired between these positions and the air flow may be directed vertically or horizontally using the setting feature on the center of the blower. Bring it to position 2 for maximum air flow.

**Park Heater:** Waste heat utilization system may be available on vehicles without a wet type heater, and it helps to keep the cab hot by passing the heated engine coolant from the radiator. If your vehicle is equipped with a waste heat utilization system, engine shall be off and the ignition shall be on to use the system. Additionally, ventilation control panel shall be activated and the ventilation fan shall be at blow position. System shall remain active as long as the coolant temperature is high enough to heat the cab after activating the system.

Simply turn the ignition off to switch the system off.

### Auxiliary heater Dry Type Heater

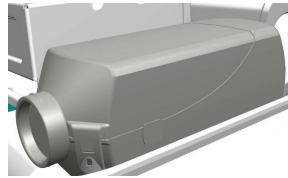

Eberspacher airtronic D2 dry type heater is used. This device is placed under the lower bed inside the cab. On/off switch is located on the front console and the right wall of the lower bed. Detailed settings may be performed on the instrument panel. Auxiliary heater can also be operated when the ignition is off.

### CAUTION

On vehicles with dry type cab heaters, air may enter to the fuel line and prevent system operation when the fuel level in the fuel tank is decreased to a certain level.

Review the error code table for the details of the error codes read on the instrument panel and the actions to be taken. (Do not turn the heater switch off and on before filling the fuel tank)

### CAUTION

Pump is sensitive. High quality diesel fuel shall be used against freezing. Auxiliary heaters may be operated while the engine is running. However, auxiliary heaters shall be turned off automatically when the ignition is turned off if the auxiliary heaters are on while the engine is on. You may press the auxiliary heater on/off button to switch them on again. If the dry type heater is operated when the engine is off, A/C control module activates for 5 minutes at every 30 minutes automatically to freshen the air inside the cab and ventilation control unit blows air from external environment to the cab. If the auxiliary heaters are operated when the engine is off, heaters resume to be active until the cab reaches the desired temperature even if the engine is operated later.



# OPERATION

## A/C and Heater

Fuel consumption: 0.28 l/h during the initial start-up when the temperature inside the cab is low; and 0.10 l/h for the operating phase.  
Blowing temperature from the nozzle is 75°C max.

Do not cover the blower and the intake nozzle inside the cab. This is important as it affects the service life and the speed of the motor.

### **CAUTION**

In-cab auxiliary heater hot air outlets are behind the driver's seat and the passenger seat.

Therefore, dangerous material such as flammable or explosive material shall not be placed between the driver's seat and bed.

### Wet type heater

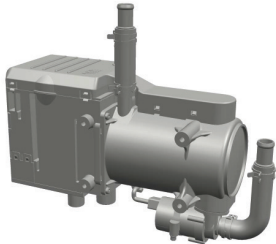

Eberspacher hydronic M2 is used. Cab is heated by heating the engine coolant with diesel fuel.  
This unit is placed under the right step on the vehicle.

This device has hoses on its own for exhaust and combustion air requirements. It is operated with diesel fuel.  
This unit adjust the cycle automatically and takes fuel from dosage pump with the help of an element sensible to the in-cab temperature.

### Maintenance

- We recommend that the heater is inspected in Ford authorized workshops in the start of each winter season.
- Keep the heater air inlet and outlet ducts clean. Dirty air ducts cause overheating and deactivation of the heater control unit.
- Operate the heater once every month for 10 minutes to prevent the jamming of the mechanical components.

### **CAUTION**

Turn off additional heating system(s) when refuelling.

### **CAUTION**

Heater should not be operated in enclosed areas as it produces exhaust gas.

### Malfunction

If the heater has a fault, check the fuse harness for safety. Contact an authorized service if the precautions below do not solve the problem.

### Cab Air Filter Replacement:

Cab air filter catches the particles in the air incoming to the cab and ensure that the cab is free of said particles. If the air flow to the cab is decreased, the filter shall be replaced before the periodic maintenance intervals. Filter shall be replaced rather than having been cleaned.

# OPERATION

## A/C and Heater

### Controls Programming

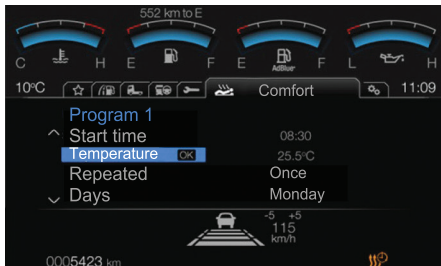

- 1. Start:** Set the schedule start time from this menu. Auxiliary heater shall operate at the time you have specified.
- 2. Temperature:** Set the schedule operating temperature from this menu.
- 3. Frequency of repetition:** Determines the frequency of repetition. Options: There are 2 options, namely once and repeated.
- 4. Day:** You may set the operating day(s) of the schedule.  
Options:  
Mon, Tue, Wed, Thu, Fri, Sat, Sun, weekdays, weekend, every day

You may set the temperature desired in the cab from 15° C and 30° C with intervals of 0.5° C. You are not allowed to set a temperature other than these values.

### Schedule On/Off

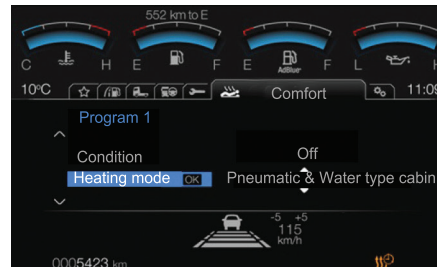

1- Turns the auxiliary heater schedule on or off.

2- Sets the heating mode

Options:  
Cab - Wet type  
Cab - Dry type  
Cab - Wet and Dry type  
Engine

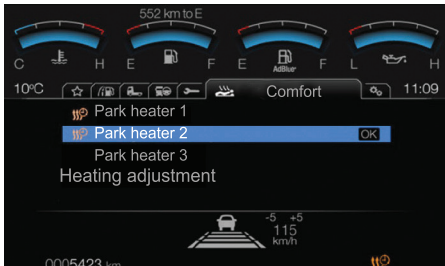

1- If the auxiliary heater schedule is set, an orange marker is displayed before the relevant schedule.

2- If the auxiliary heater schedule is set, control lamp is illuminated on the digital display.

You may select the operating period of your heater as desired; you do not need to turn the ignition on for unlimited operation. Heater may be operated at desired period even if the ignition is off.

If the dry type or wet type heater is activated with the buttons on the front console or on the bed compartment, it shall be turned off automatically after 10 hours maximum. If the dry type or wet type heater is from the instrument panel,

it shall be turned off automatically after 2 hours maximum.

### **CAUTION**

Automatic scheduling for auxiliary heater is deactivated on vehicles carrying dangerous goods (vehicles with ADR) for safety reasons.

### **CAUTION**

The main switch shall not be switched off before the auxiliary heater is stopped. If the button is turned off before the heater goes through a certain re-operation period, it may be damaged.

### **CAUTION**

When both wet and dry heaters are used at the same time, we recommend you to cancel automatic mode for conditioning selection to achieve a better heating performance

# OPERATION

## A/C and Heater

### Auxiliary heater error codes (Dry type)

Fault Code Read From the Heater	Malfunction description	Explanations
		• Corrective action
4	Warning: Short circuit on the control box, at the fresh air outlet	Call the authorized service
5	Warning: Short circuit on the control box, at the vehicle alarm outlet	Call the authorized service
6	Warning: Unexplainable atmospheric altitude information	Call the authorized service
9	(Displayed in heaters with a "H-Kit" label on name plate only.)	Call the authorized service
10	ADR interrupted.	Call the authorized service
11	Over voltage - interruption	Call the authorized service
C	Low voltage - interruption	• Check hot air pipes against blockage → remove the blockage.
	Excessive heating in the excessive heating sensor	Call the authorized service if the problem is not solved
D	Excessive heating in the flame detector	• Check hot air pipes against blockage → remove the blockage.
E	Temperature difference between flame detector and excessive heating sensor	Call the authorized service if the problem is not solved
F	Operation locked	• Check hot air pipes against blockage → remove the blockage.
11	Overheating	Call the authorized service if the problem is not solved
12	Starting power of the glow plug is very low (Displayed in heaters with a "H-Kit" label on name plate only.)	Call the authorized service
13	Ignition power is too low	Call the authorized service
14	Glow plug - interruption	Call the authorized service
15	Glow plug - short circuit, short circuit after overload or negative load	Call the authorized service
16	Glow plug, output (+) - short circuit after UB (battery voltage)	Call the authorized service
19	* Diagnostic cable bl/ws - short circuit after UB (battery voltage)	Call the authorized service
1F	Blower - interruption	Call the authorized service
20	Blower motor - short circuit after negative	Call the authorized service
	Please note!	
	Provide compliance with the test voltage	
	Part is destroyed if the voltage value is exceeded. Make sure that the power supply has adequate short circuit resistance (20 A minimum).	

# OPERATION

## A/C and Heater

4

Fault Code Read From the Heater	Malfunction description	Explanations
		• Corrective action
21	Blower motor does not rotate or short circuit after negative	Call the authorized service
	Please note!	
	Provide compliance with the test voltage	
	Part is destroyed if the voltage value is exceeded. Make sure that the power supply has adequate short circuit resistance (20 A minimum).	
22	Blower motor, output (+) - short circuit after UB (battery voltage)	Call the authorized service
2F	Metering pump - short-circuit or overload	Call the authorized service
30	Metering pump - interruption	Call the authorized service
31	Metering pump output (+) - short circuit after UB (battery voltage)	Call the authorized service
32	Too many failed operation attempts (operation locked)	Call the authorized service
33	Flame detected during operation	Call the authorized service
34	Safety time exceeded	No flame detected during operation cycle.
		• Check the exhaust and combustion air system.
		* Check the fuel supply / fuel amount
		Call the authorized service if the problem is not solved
35	Flame interruption during "POWER" control	Heater ignited during power stage (flame detected) and flame interruption signal issued.
		• Check the exhaust and combustion air system.
		* Check the fuel supply / fuel amount
		Call the authorized service if the problem is not solved
36	Flame interruption during "HIGH" control stage	Heater ignited during power stage (flame detected) and flame interruption signal issued.
		• Check the exhaust and combustion air system.
		* Check the fuel supply / fuel amount
		Call the authorized service if the problem is not solved
37	Flame interruption during "MEDIUM" control stage	Heater ignited during power stage (flame detected) and flame interruption signal issued.
		• Check the exhaust and combustion air system.
		* Check the fuel supply / fuel amount
		Call the authorized service if the problem is not solved

# OPERATION

## A/C and Heater

Fault Code Read From the Heater	Malfunction description	Explanations
		• Corrective action
38	Flame interruption during "LOW" control stage	Flame interruption detected during operation cycle.
		• Check the exhaust and combustion air system.
		* Check the fuel supply / fuel amount
		Call the authorized service if the problem is not solved
39	Flame interruption during operation stage (Displayed in heaters with a "H-Kit" label on name plate only.)	No flame detected during operation cycle.
		• Check the exhaust and combustion air system.
		* Check the fuel supply / fuel amount
		Call the authorized service if the problem is not solved
3C	External temperature sensor - interruption	Call the authorized service
3D	External temperature sensor - short circuit	Call the authorized service
3E	Control unit interruption	Call the authorized service
3F	Control unit short circuit	Call the authorized service
	Fault detection works at heating mode only.	
	On the other hand, if the short circuit already happened and then the heater is turned on, "Ventilation" shall be activated (this is not an error code).	
40	Flame detection - interruption	Call the authorized service
41	Flame detector - short circuit	Call the authorized service
47	Overheating detector - interruption	Call the authorized service
48	Overheating detector - short circuit	Call the authorized service
4A	Control box faulty	Call the authorized service
5A	Control box faulty (internal error)	Call the authorized service
5B	External interference voltage	Call the authorized service
5C	Control box faulty (ROM error)	Call the authorized service
5D	Control box faulty	Call the authorized service
5E	Control box faulty (EEPROM error)	Call the authorized service
5F	Control box faulty	Call the authorized service
60	Internal temperature sensor faulty	Call the authorized service
61	Control box faulty	Call the authorized service
62	Control box faulty	Call the authorized service
63	Too many successive resets Transistor error in the control box	Call the authorized service

# OPERATION

## A/C and Heater

### Auxiliary heater error codes (water type)

Fault Code Read From the Heater	Malfunction description	Explanations
		• Corrective action
5	Warning Short circuit on the "Burglary Alarm" output	Call the authorized service
9	ADR / ADR99 off	Turn the heater off and on again.
A	Over voltage interruption	Call the authorized service if the problem is not solved
B	Low voltage interruption	Call the authorized service
C	Overheating	Call the authorized service
E	Difference between overheating detector and temperature sensor is too big	Call the authorized service
11	Overheating,	Call the authorized service
	Equipment threshold exceeded	
	Control box locked	
13	Glow plug 1, Ignition power is too low	Call the authorized service
14	Glow plug 1, interruption	Call the authorized service
15	Glow plug 1, overload / short circuit after grounding	Call the authorized service
16	Glow plug 1, short circuit after +UB	Call the authorized service
17	Glow plug 2, interruption	Call the authorized service
18	Glow plug 2, overload / short circuit	Call the authorized service
19	JE-K line fault	Call the authorized service
	Heater is kept ready for operation	Call the authorized service
1A	Glow plug 2, short circuit after +UB	Call the authorized service
1D	Glow plug 2,	Call the authorized service
	Ignition power is too low	Call the authorized service
1F	Combustion engine, interruption	Call the authorized service
20	Combustion engine, overload	Call the authorized service
21	Overload, speed error / blocked	Call the authorized service
22	Combustion engine, short circuit after +UB or grounding	Call the authorized service
25	Water pump does not operate	Call the authorized service
29	Water pump, interruption	Call the authorized service
2A	Water pump, Overload / short circuit	Call the authorized service
2B	Water pump, Short circuit after +UB	Call the authorized service
2F	Metering pump	Call the authorized service
	Overload / short circuit	
30	Metering pump interruption	Call the authorized service

# OPERATION

## A/C and Heater

4

Fault Code Read From the Heater	Malfunction description	Explanations
		• Corrective action
31	Metering pump, Short circuit after +UB	Call the authorized service
34	Safety time exceeded	No flame detected during operation cycle.
		• Check the fuel supply, the exhaust and the combustion air system.
		Call the authorized service if the problem is not solved
35	Flame interruption:	Heater ignited during power stage (flame detected) and flame interruption signal issued.
	"POWER" control stage	• Check the fuel amount, the blower speed, the fuel supply and the exhaust and the combustion air system.
		Call the authorized service if the problem is not solved
36	Flame interruption:	Heater ignited during power stage (flame detected) and flame interruption signal issued.
	"HIGH" control stage	• Check the fuel amount, the blower speed, the fuel supply and the exhaust and the combustion air system.
		Call the authorized service if the problem is not solved
37	Flame interruption during "Medium" control stage (D 8 W / D 10 W)	Heater ignited during power stage (flame detected) and flame interruption signal issued.
	"Medium1" control stage (D 12 W)	• Check the fuel amount, the blower speed, the fuel supply and the exhaust and the combustion air system.
		Call the authorized service if the problem is not solved
38	Flame interruption:	Heater ignited during power stage (flame detected) and flame interruption signal issued.
	"Medium 2" control stage (D 12 W)	• Check the fuel amount, the blower speed, the fuel supply and the exhaust and the combustion air system.
		Call the authorized service if the problem is not solved



# OPERATION

## A/C and Heater

Fault Code Read From the Heater	Malfunction description	Explanations
		• Corrective action
39	Flame interruption:	Heater ignited during power stage (flame detected) and flame interruption signal issued.
	"Medium 3" control stage (D 12 W)	<ul style="list-style-type: none"> <li>• Check the fuel amount, the blower speed, the fuel supply and the exhaust and the combustion air system.</li> <li>• Call the authorized service if the problem is not solved</li> </ul>
3A	Flame interruption:	Heater ignited during power stage (flame detected) and flame interruption signal issued.
	"LOW" control stage	<ul style="list-style-type: none"> <li>• Check the fuel amount, the blower speed, the fuel supply and the exhaust and the combustion air system.</li> <li>• Call the authorized service if the problem is not solved</li> </ul>
3B	Water temperature increasing too quickly	Call the authorized service
3C	Temperature sensor interruption	Call the authorized service
3D	Temperature sensor short circuit	Call the authorized service
40	Flame detector interruption	Call the authorized service
41	Flame detector short circuit	Call the authorized service
47	Overheating detector interruption	Call the authorized service
48	Overheating detector short circuit	Call the authorized service
4A	Sensing equipment faulty on the overheating detector, operation locked	Call the authorized service
5A	External reset	Call the authorized service
5B	Internal reset	Call the authorized service
5C	ROM error	Call the authorized service
5D	RAM error, at least one RAM cell does not operate	Call the authorized service
5E	EEPROM error, operation data, diagnostic parameters or checksum error in the setting values field	Call the authorized service
5F	Invalid data record checksum error	Call the authorized service
60	Internal temperature sensor faulty	Call the authorized service
	/ ECU too hot	
61	Internal device error	Call the authorized service
62	Main relay faulty	Call the authorized service
63	Too many resets, operation locked	Call the authorized service

# OPERATION

## Driving

### Before taking off



Check the air pressures on the brake circuits.



#### CAUTION

Visual and audible warnings are displayed on the screen when brake air level is low in the vehicle. Do not bring the parking brake to drive position and attempt to drive the vehicle before the stopping of the visual warning and the buzzer.

### Starting the engine

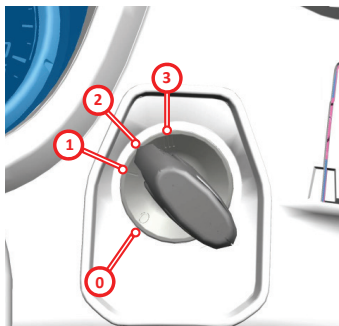

Turn the ignition on.

- Bring the ignition switch to position **2**. Wait until the engine warning lamp is turned off. Refer to maintenance and service chapter MIL lamp.
- Switch the engine on by turning the ignition switch to **3** position while the gear is at neutral. (allowed for max. 15 seconds)
- Wait for 15 seconds if the engine does not start and repeat the same procedure in the same order.



#### CAUTION

Wait for the period determined by the electronic control unit (10 to 60 seconds) before starting again after a start failure. Do not attempt to start in this period.

### Cold Starting of the Engine

Turn the ignition on. (position **2**) cold starting lamp shall be continuously on.



- Start the engine (position **3**) when the cold start lamp turns off,
- If the engine does not start, switch the ignition off, wait for 10 minute and repeat the steps above.

### Starter Protection System

Starter Protection System is a system that prevents the burning of the starter due to unnecessary starting operations. Electronic control unit calculates the maximum appropriate duration of a starting operation by gathering many data via the sensors on the engine to protect the starter.

When the user exceeds the specified maximum start duration, he is prevented from starting again.

The system allows starting again at the end of the period determined by the electronic control unit.

Please follow the instructions below in such a case.



### CAUTION

If your engine is not started after some attempts, there may another problem in another system of your engine. First complete the other checks, and attempt to start again.

#### To stop the engine

Do not stop the engine right after the vehicle is stopped, wait until the turbocharger speed is reduced by operating the engine in idle for 2 minutes. If the engine is stopped immediately when the vehicle is stopped, the turbo which is rotating in high speed shall not be adequately lubricated.

#### Air deflector

Adjust the air deflector on the cab according to the trailer.

**Note:** A correctly adjusted air deflector reduces the fuel consumption.



### WARNING

There is a risk of falling down from the cab and being injured while adjusting the air deflector.

We advise you on that adjustments on the air deflector shall be performed by FORD OTOSAN authorized dealership with the required expertise and special equipment.

#### Smart acceleration feature:

Acceleration of the vehicle is controlled by limiting the engine acceleration profile to a specified percentage of the maximum weight that can be carried by the variant for trucks, and maximum load that can be drawn for the tractor trucks.

Abrupt and unintentional accelerator responses of the unloaded vehicle have been prevented, and thus driveability of the vehicle is improved besides providing fuel economy. Smart acceleration function is deactivated especially in uphill start and climbing manoeuvres and it is optimized to prevent adverse effect on the vehicle performance.

# OPERATION

## Driving

### Cruise Control System Principal of Operation

Cruise control system allows you to maintain the set speed without keeping your foot on the accelerator pedal. You may use cruise control system when your vehicle speed exceeds 30 km/h.

### Operation of Cruise Control System



#### WARNING

Do not use cruise control in heavy traffic, on winding roads or when the road surface is slippery. This may cause the loss of the control of the vehicle and accidents that may cause serious injuries or death.



#### WARNING

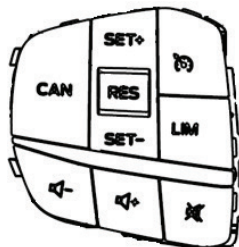

When you are going downhill, your speed may exceed the set speed, the system shall reactivate once the vehicle speed drops below the set speed. Change down a gear and press the SET- switch to assist the system in maintaining the set speed. When the cruise control is activated, it is automatically deactivated in the following conditions:

- Applying the brake
- Activating the engine brake
- Pressing the accelerator pedal shall deactivate cruise control system automatically.



Speed controls are located on the steering wheel.

### Turning the Cruise Control System on

Press cruise control symbol  and release it. The  symbol shall be displayed on the indicator.

### Adjustment of Drive Speed

1. Accelerate to the desired speed.
2. Press **SET+** or **SET-** and release.

3. Take your foot off the acceleration pedal.

**Note:** The colour of the display changes.

### Changing the Set Speed

- Press and release the **SET+** or **SET-** button.
- Press the accelerator or brake pedal until you reach the desired speed. Press and release the **SET+** or **SET-** button.

**Note:** If you accelerate by pressing the accelerator pedal, the set speed shall not change. When you release the accelerator pedal, your vehicle shall return to the speed that you have previously set.

### Cancelling the Set Speed

Press and release the CAN button or press the brake pedal. The set speed shall not be deleted.

### Resuming the Set Speed

Press and release the RES button.

### Turning the Cruise Control System off

Press cruise control symbol and release it when the system is at the waiting position or after turning the ignition off.

**Note:** Set speed is deleted when you turn the system off.

### MaxCruise® - Predictive Speed Control System Principal of Operation

MaxCruise® is a function that operates inside cruise control system and that affects the fuel economy by keeping the vehicle speed within the specified speed limits as per the information on the road. You may use this function while cruise control system is effective.

### Using the MaxCruise® - Predictive Speed Control System

MaxCruise® adds the speed band values selected by the driver both as positive and negative based on the driving speed set in the cruise control system. The system tries to keep the vehicle speed within these values and at the same moves the vehicle at the speed with the minimum fuel consumption independent of the driver.

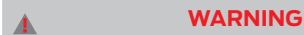

Auxiliary brakes of the vehicle may be activated when the speed of the vehicle exceeds the upper limit specified for the MaxCruise® system. In such a case, the system is not deactivated.



### WARNING

In some cases, vehicle speed may exceed the speed band values even if the auxiliary brakes are activated. Vehicle shall display a visual warning on the instrument panel in such cases. Ensure that the vehicle speed is kept at the safe level by changing the speed values set in this case.

### Turning the MaxCruise® - Predictive Speed Control System on

To turn the MaxCruise® system on, you shall specify the upper and lower limit speeds for the system. There are two ways to specify these values. You shall go to the MaxCruise® system level selection screen under the drive assists tab in the instrument menu of the vehicle. Or you can go to this screen by pressing  twice on the cruise control icon.

There are 4 levels in this screen. Off, Level 1, Level 2, Level 3



User may select these levels by using the bottom and top menu buttons. Value to be selected shall be selected by pressing the OK key in the menu. The leaves of the selected level shall turn from grey to . These levels change the upper and lower limit of the set drive speed of the vehicle. Points to be considered while selecting the levels in this respect:

- While selecting the level, pay attention to the lower and upper speed values specific to that level on the indicator display. Vehicle shall add or remove these values to the drive speed and try to keep the speed between these values.
- The higher the level, the more fuel economy shall be obtained. This condition is shown on the display with fuel economy leaves . The more number of leaves, the more fuel economy.

# OPERATION



## Driving

4

- It is important that the driver selects especially the upper limit so that it shall be lower than the permissible speed limit as the upper and lower limits of the driving speed of the vehicle shall change. The driver is responsible for possible increases in the speed.

The level selection of the MaxCruise® system may be performed while the vehicle is moving or stopped, and the selected level shall be activated when the vehicle is restarted.

To operate the MaxCruise® system:

1. Set the MaxCruise® system level to a position other than OFF.
2. Turn the cruise control system on.
3. Set the vehicle speed to a certain value.
4. Remove your foot off the accelerator pedal.
5. Ensure that  or  symbol is displayed on the screen.
6. Make sure that the upper and lower speed values specified in the level selection appear on the display where the driving speed is displayed.



### WARNING

While the MaxCruise® system is active, the cruise control system is also active at the same time. In this respect, adjustment and cancellation of the set speed of the cruise control system as described in the cruise control system are possible, and these changes shall also affect the MaxCruise® system.



### WARNING

The upper speed limit values at different levels of the MaxCruise® system may vary according to the values specified for the driving speed of the vehicle in the cruise control system. In this respect, there is a maximum limit for the upper limit, and when the level is set, this limit is displayed to the driver on the level adjustment screen. Also, the upper band of the MaxCruise® system, which is actively displayed on the main screen of the instrument panel, may vary depending on the changing driving speed.

### Changing the Set Level

The MaxCruise® system level set may be changed on the relevant screen by the method mentioned above regardless of whether the system is active or not. Changing the set speed of the cruise control system shall not change the level.

### Turning the MaxCruise® - Predictive Speed Control System off

MaxCruise® system shall be deactivated when the set level is brought to OFF position.

### Using Adaptive Speed Control System

Always pay attention to changing road conditions, especially when adaptive speed control system is used. The use of an adaptive cruise control system does not replace careful driving. Otherwise, you may cause an accident that could result in serious injuries or death.

Do not use the adaptive cruise control system when entering or exiting a highway, at intersections or roads with roundabouts, at traffic with no vehicle, or on rolling, slippery, unpaved roads or steep slopes.

Do not use the system in the case of bad visibility, for example when there is fog, heavy rain, drizzle or snow.

Do not use tires with dimensions other than those recommended as the normal operation of the system may be affected. If you use the system, you may lose control of the car in such a way that may result in serious injuries.

The adaptive cruise control system may not detect vehicles that are stationary or moving at a speed of less than 10 km/h.

The adaptive cruise control system does not detect the pedestrians or objects on the road.

The adaptive cruise control system does

not detect oncoming vehicles at the same lane.

The adaptive cruise control system is not a collision warning or prevention system.

The system helps you to maintain the distance between you and the vehicle in front of you. The system adjusts the vehicle speed to maintain the distance between your car and the vehicle in front of you. The system applies brakes to slow down your vehicle in order to maintain the distance with the vehicle in front of you.

**Note:** It is your responsibility to stay alert, drive safely and be in control of the vehicle at all times.



Controls of the adaptive speed control system are located on the steering wheel.

### Turning the Adaptive Speed Control System on



Press and release the switch. Gray indicator light is displayed on the information display. System is now at stand-by.



Indicator, current distance setting and the set speed are displayed on the information display.

### Adjustment of Drive Speed

Accelerate to the desired speed.



Push the button up to set the current speed.

1- Take your foot off the acceleration pedal.

2- Green indicator light and the current distance setting shall be displayed



# OPERATION

## Driving

3- Vehicle symbol is lit if a vehicle is detected in front of you.

**Note:** When the adaptive speed control system is activated, the speed displayed on the information display may be slightly different than the set speed.

### Following a Vehicle

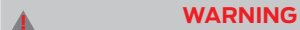

While following a vehicle, your vehicle shall not slow down automatically to stop or slow down quickly to prevent a collision without interruption of the driver. Apply brakes when required. Otherwise, you may cause an accident that could result in serious injuries or death.

The adaptive speed control system brakes up to 30% of the maximum deceleration of your vehicle. The adaptive speed control system shall give a visual warning and sound a buzzer if this deceleration is not adequate. There is a risk of accident in such a case.

Apply brakes yourself and attempt to make avoiding manoeuvres in such a case. The adaptive speed control system provides warnings on the vehicles detected with radar sensor only. In some cases there may be no warning or the warning may be delayed. You should

always apply the brakes when necessary.

Otherwise, you may cause an accident that could result in serious injuries or death.

Vehicle speed is adjusted when a vehicle in front of you enters your lane or if there is a slower vehicle at the same lane to maintain the distance set.

**Note:** A sound may be heard when brakes are applied by the system.

When following a vehicle, the system may temporarily accelerate your vehicle slightly when you operate the turn signal towards the driver's side.

Your vehicle shall continue to maintain the distance from the vehicle in front of you until the following conditions occur:

- When the vehicle in front of you accelerates to a speed above the set speed.
- When the vehicle in front of you comes out of your lane or disappears from sight.
- When your vehicle speed drops below 30 km/h
- When a new following distance is set

The system applies auxiliary brakes and pedal brakes to slow down your vehicle in order to maintain the distance with the vehicle in front of you. The system carries out the maximum braking as limited. Press the brake pedal to deactivate the system. If the system decides that the maximum braking effect shall not be adequate, a warning buzzer is played and a message is displayed on the information display while the system continues to apply the brakes. You shall take precautions immediately.

### Adjusting the Distance



By pressing the distance control you may reduce or increase the distance between your car and your vehicle in front of you.

**Note:** It is your responsibility to select a distance that is suitable for the driving conditions.





The selected distance is shown as a bar graph in the information display. You may select four distance values.

Graphic Display, Distance Between Vehicles is Displayed With Bars	Distance Between Vehicles	Dynamic Action
1	Closest.	Sport.
Emergency Management	Close.	Normal.
3	Medium.	Normal.
4	Distant.	Comfort.

The distance setting is set to Medium whenever you turn the ignition on.

### Cancelling the Set Speed



#### WARNING

If you deactivate the system by pressing the accelerator pedal, it shall not brake automatically to maintain the distance from the vehicle in front of you.

Use the accelerator pedal in a normal way to exceed the set speed limit deliberately. Set Speed is displayed as invalid when you disable the system.

The system continues to work when you release the gas pedal. The vehicle speed falls to the set speed or falls to a lower speed if you are following a slower vehicle.

### Changing the Set Speed



Press the button down to decrease the set speed.

The set speed changes in small increments.

**Note:** Press and hold the button up or down to change the set speed at larger increments.

The system may apply brakes to bring the vehicle to the new set speed. When the system is activated, the set speed value is continuously displayed on the information display.

### Cancelling the Set Speed



Press and release the switch or press the brake pedal.

The last set speed and distance setting are displayed in grey, but they do not disappear from the screen.

### Resuming the Set Speed



Press and release the switch.

The vehicle of your speed returns to the previously set speed and distance. The set speed is displayed on the information display as long as the system is active.

**Note:** Resume the set speed if you know the set speed and want to use this speed only.

### Auto Cancellation

The system shall not operate at speeds below 30 km/h. If the vehicle in front is slower and the system starts to apply brakes to adjust the distance, a warning buzzer is sound and the automatic braking is continued in limited braking mode.

The system may also be deactivated automatically in the following situations:

- When you shift to neutral
- When you disable ESP
- When the wheels slip.
- When the engine speed is too low.
- When you apply the parking brake.
- When you activate the auxiliary brakes manually.
- When there is a fault in the brake system/electronic management system

# OPERATION

## Driving

### Operation at Down Slopes

**Note:** If the brakes are applied for a long time, a warning buzzer is sound and system is deactivated. This allows cooling of the brakes. System operates normally again after the brakes are cooled.

If you are using the system in manual mode, you should select a lower gear to use the auxiliary brakes instead of the pedal brakes when the system is activated, for example when you are travelling long distances uphill or downhill, such as on mountainsides. If you use are using the system in automatic gear mode, the transmission shall set the gear automatically.

### Turning the Adaptive Cruise Control System off



Press and release the switch.

**Note:** Set speed is deleted when you turn the system off.

### Problems of Detection



#### WARNING

For example, there may be detection problems due to infrastructures such as bridges, tunnels and safety barriers. In these cases the system may brake late or unexpectedly.

At all times you are responsible for controlling the vehicle, supervising the system and intervening, if required.

The radar sensor has a limited field of vision. In some cases vehicles may not be detected at all or detected as later than expected. Vehicle in front symbol is not displayed if the system does not detect a system in front of you.

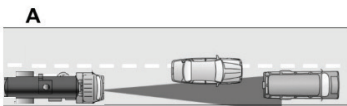

A

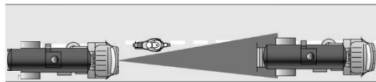

B

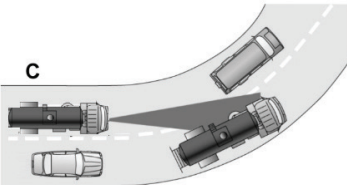

C

E71621

### Detection issues can occur:

A. With vehicles on the edge of your lane that may only be detected once they have moved fully into your lane.

B. Motorcycles may be detected late, or not at all.

C. With vehicles in front when going into and coming out of a bend. The detection beam shall not follow sharp curves in the road.

In these cases the system may brake late or unexpectedly. You should stay alert and intervene if necessary.

Radar sensing area may change if the front of the vehicle gets damage or if something hits to the front of the vehicle. This may lead to incorrect detection or lack of detection. We recommend you to contact a Ford Authorized Service as soon as possible.

### System cannot be used

Following are included in the conditions that cause the system to deactivate and that prevent activation of the system.

- Blocked sensor.
- High brake temperature.
- Malfunction in the system or in a relevant system.

# OPERATION

## Driving

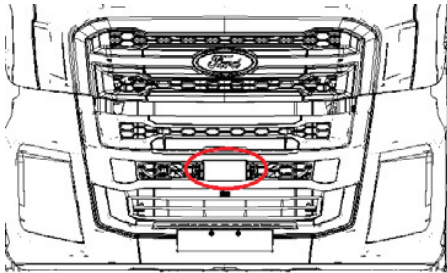

A message is displayed when the radar signals taken from the sensor are blocked by an object. The sensor is located behind the grille. When the sensor is blocked, the system cannot detect the vehicle in front, and thus cannot operate.

**Note:** You cannot see the sensor, it is located under the panel.

Keep the front of your car clean and do not keep metal badges or other objects on the vehicle. Vehicle front protectors and retrofitted lamps may also block the sensor.

Reason	Procedure
The radar surface inside the grill is dirty or covered with something.	Clean the grill surface in front of the radar or remove the covering object.
Radar surface is clean, but there is still a message on the screen.	Wait for a short period of time. It may take a few minutes before the radar finds out there is nothing in front of it.
Excessive rain or snow blocks radar signals.	Do not use the system in such conditions as it shall not be able to detect the vehicles in front.
Water, snow or ice on the road surface may block the radar signals.	Do not use the system in such conditions as it shall not be able to detect the vehicles in front.
When you are in a desert or remote area where there are no other vehicles or road markings in your vicinity.	Wait for a short time or switch to normal speed control.

### Switching to Normal Speed Control



#### WARNING

Speed control does not apply brakes when you are approaching slower vehicles. Always be aware of the operating mode you have selected and apply brakes when required.

You may switch from adaptive speed control to standard speed control using the information display.



If you select normal speed control, the adaptive speed control system indicator lamp shall be replaced with the normal speed control indicator lamp. Distance value is not indicated, the system does not automatically respond to vehicles in front, and automatic braking does not work. The system recalls the last setting you made when you have used your vehicle.

# OPERATION

## Driving

### Speed Limiter

#### Principal of Operation



#### CAUTION

When you are going downhill, your speed may increase above the set speed. When you are going downhill, speed limiter brakes the vehicle automatically with auxiliary brake to resume the speed limit. **LIM** symbol flashes on the screen if the set speed is exceeded.

System is designed to support the driver. However, the system does not relieve you of the responsibility to be attentive and to decide correctly. The driver is always responsible for driving the vehicle with the required care and attention.

Speed limiter resumes to be active until the ECU sleeps after the engine is turned off, then it is deactivated.

The system allows you to set a speed value to limit your vehicle speed. The speed limit set shall be the active maximum speed of your vehicle. The

speed limit set may be exceeded provisionally in cases such as overtaking.

#### Using the Speed Limiter

The buttons are located on the steering wheel.

#### Switching the System On and Off

**LIM** Press the LIM button to switch the system to stand-by mode. Press the LIM button again to turn the system off.

#### Setting the Speed Limiter

**SET+** **SET-** While the system is at stand-by mode, press the speed up or down button to set the speed limiter to the current vehicle speed. The speed limit is recorded and displayed on the information display. Speed limit may be set with smaller or larger increments. Press the up or down button to change the set speed with smaller increments. Press and hold the up or down button to change the set speed with larger increments. To activate the speed limiter, activation

conditions of the PTO speed controller shall not be met (PTO activation conditions are for example, vehicle at standstill, park brake applied, shift at neutral, brake pedal not pressed, etc.) Otherwise, PTO speed controller shall be activated.

#### Cancelling the Set Speed

**CAN** Press the cancel (CAN) button to cancel the set speed. System returns to Stand-by mode.

#### Resuming the Set Speed

**RES** Press the RES button to resume the set speed.

#### Intentionally Exceeding the Set Speed Limit

Press the accelerator pedal fully to provisionally exceed the set speed limit deliberately. System resumes the set speed when the current speed is lowered to a speed below the set speed or when you press the RES button.

### Remote Software Update

Remote software update is a function that allows downloading new software that applies to your vehicle automatically and installing of such software with the approval of the user.



#### CAUTION

The SIM card in your vehicle shall be activated in order to use the remote software update function.

### Using the Remote Software Update System

You shall be informed about a software update by the instrument panel when you turn the ignition on for the first time when there is a new software update for your vehicle. To start the software update, enter the software update sub-menu under the maintenance menu, and ensure that:

- Your vehicle is at standstill,
- Park brake is applied,
- Engine is not on and press and hold the OK key on the menu for 3 seconds.

If there are more than one software available for your vehicle, software update procedure shall start with the installation of the software with higher priority. Number of software updates available shall be displayed on your screen after each successful software update procedure. If the number of software updates is "0", you have no new software remaining for your vehicle.



#### WARNING

When the software update is confirmed by the user, system shall check whether some other requirements are also met in addition to the requirements specified above.

If the prerequisites are not met (e.g., When the battery voltage is not adequate) software update procedure shall not be started.



#### WARNING

Do not turn the ignition off after starting the software update and do not start the engine until the procedure is completed. Your engine control unit may be restarted during the software update procedure. Wait until the relevant messages are displayed on the instrument panel and do not take any action before in such a case.



#### CAUTION

If you encounter any technical faults during software update or if you encounter a message indicating that the procedure has failed, attempt to restart the procedure first. If the procedure fails still, contact your nearest authorized service representative.

# OPERATION

## Driving

### Hill launch assist

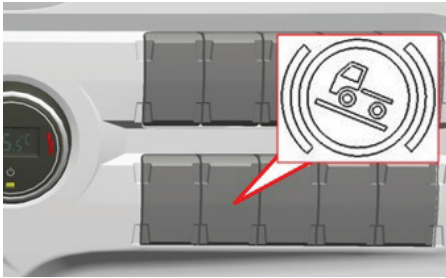

- 1- Stop the vehicle with service brake.
  - 2- Activate the hill launch assist by pressing the button on the center console.
  - 3- Release the brake pedal.
  - 4- Hill launch assist holds the brake for a maximum of 2.5 seconds. If the engine torque reaches the specified level earlier, hill launch assist is deactivated before 2.5 seconds.
- Hill start assist active warning is displayed on the instrument when the hill start assist is active.

### Fifth wheel position change

If necessary, the position of the fifth wheel can be changed by shifting it a maximum of one hole in the direction of the vehicle cab.

### Disc brake system

Brake System: Arvin Meritor Elsa 225H air disc brake with sliding brake calliper.  
Disc: 430 mm anti-conical disc with air ducts. System Air Pressure: 12,5 bar

### Brake friction pads

The new brake pad thickness is 19mm. Brake pads should be replaced when they fall to 3 mm thickness. Vehicles with disc brakes have a sensor on each brake that constantly measures the amount of wear. The display screen shows how many kilometers the pad of the brake pad on each axle will go in <<KM>>. Data is collected for a predetermined period of time based on the driver and usage conditions, and is displayed on the display as an hourglass. Different wear between right and left brake pad, brake pad sensor error, general error, remaining brake pad life under 6% and installing worn brake pad under 35% are shown on the display in <<--->> and the problem should be solved by going to service. When the amount of brake lining in any brake approaches the end, the driver is informed with the warning light. After the warning light turns on, the problem should be

solved by going to the nearest service.

An indicator lever is available on the brake to allow monitoring of the lining thickness besides the percentage indication on the display. Linings shall be replaced when the indicator lever is fully worn.

As the service life of the lining shall differ greatly due to causes such as vehicle load, operating conditions etc., monitor the lining thickness periodically from the display or check it every month with the indicator lever on the brakes when it is not possible to monitor it from the display.

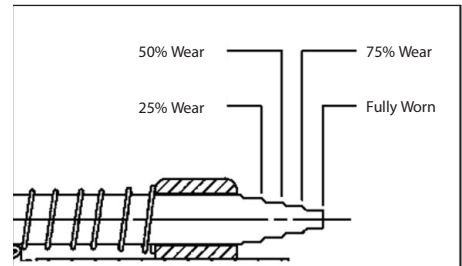
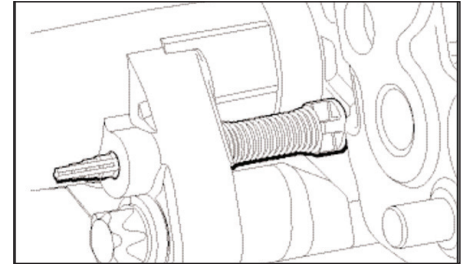

# OPERATION

## Braking

### Disc Brake System

The thickness of the new discs is 45 mm. Discs shall be replaced when the thickness becomes lower than 39 mm. Check the disc thickness every three months as the service life of the disc shall differ greatly due to causes such as vehicle load, operating conditions etc. Inspect the disc surface against cracks during thickness inspection.

Replace the disc if the cracks on the surface has reached air ducts or grown up to 25% of the lining pressure surface. Cracks that have not grown up to 25% of the surface do not affect the performance, you may continue to use the disc.

Blue areas on the disc surfaces indicate that they have been subject to excessive heating. We recommend you to machine the disc as the structure of these areas have been deformed. Linings that have been subject to excessive heating shall also be replaced.

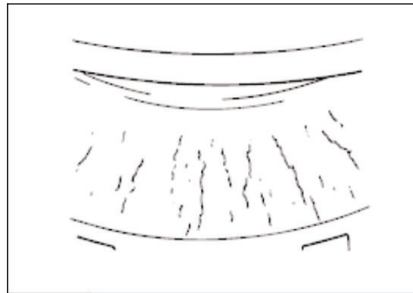
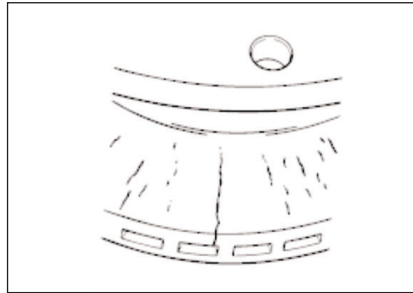

### Drum Brake System

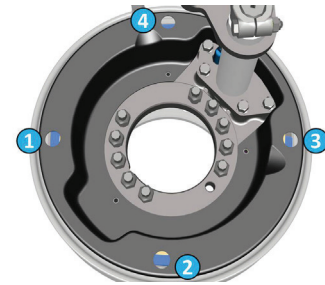

Z-cam brake system is a lining-drum type braking system. Brake lining wear is inspected from 4 holes on the brake plate. Remove the plugs on the plate for inspection, and replace them after inspection.

\*Z-cam brake system is optional.



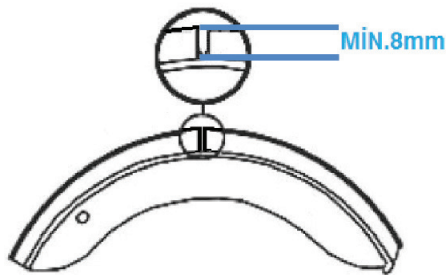

Lining wear inspection may also be performed visually from the inspection holes on the brake dust plate.

If the thickness of the lining remaining on the brake pad is less than 8mm, we recommend that you shall have your lining replaced in a Ford Trucks authorized service immediately.



### CAUTION

Even if one of the mutual linings is worn, replace both linings.



### CAUTION

Install the plugs again after lining inspection. Otherwise, dust and dirt ingress between the lining and drum may cause premature lining wear and damage to the drum.

# OPERATION

## Braking

### Emergency brake bellows

Brake air bellows on the drive axle of your vehicle have emergency feature. Emergency bellows are activated in 2 conditions:

- When the park brake is applied
- When there is not enough air in air tubes to brake the vehicle



### Discharging the emergency bellows

To discharge the emergency bellows, turn the bolt behind the bellow in tightening direction (clockwise) completely.



### CAUTION

No braking shall be available to hold the vehicle in place when the emergency bellows are discharged. Do not discharge the bellows before taking necessary safety precautions.



### CAUTION

To start park brake mechanism again, please contact to the authorized workshops or refer to the repair catalogue. If the vehicle is going to be parked for more than a month, perform the following to protect the linings and drums.

- Park the vehicle, chock the wheels and release park brake lever.
- Drain air tanks completely.
- Release the park brake unit as specified depending on the vehicle model.
- Run park brake unit and refill the system with air when you will drive the vehicle again.

# OPERATION

## Braking

### Engine brake (Standard)

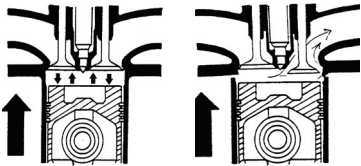
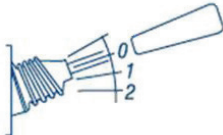

Fig. 1 Fig. 2

Your engine provides the engine brake feature as standard. At the end of the compression cycle (Fig. 1), before several degrees from the Top Dead Center, a special equipment in engine pistons opens the exhaust valves a little and releases the pressure grown inside the cylinder (Fig. 2). Thus, braking torque of the compression cycle is used.

### Activation of the engine brake



	Engine Brake
1. Range	Reduced Brake Power
2. Range	High Brake Power

Engine brake is activated by the lever on the right of the steering. warning is displayed on the indicator. Retarder / optional Retarder is a special brake system for decelerating the vehicle and maintaining the speed in downhill travels, and also known in the market as "drive shaft brake". Retarder provided in your vehicle has a hydrodynamic braking system also known in the market as fluid type.

- Braking Moment: 3,650 Nm
- Braking Power: 500 kW
- Weight: 52 kg
- Operating principle: Hydrodynamic braking

• Fully compliant with ABS-EBS system

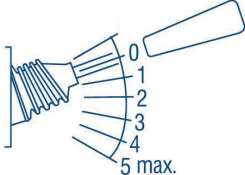

Retarder is activated by the 5 step lever on the right of the steering.

	Engine Brake	Retarder
Retarder 1	50% Max. Brake Power	20% Max. Brake Power
Retarder 2	50% Max. Brake Power	40% Max. Brake Power
Retarder 3	100% Max. Brake Power	60% Max. Brake Power
Retarder 4	100% Max. Brake Power	80% Max. Brake Power
Retarder 5	100% Max. Brake Power	100% Max. Brake Power

warning is displayed on the display when the retarder is activated. Bring the retarder lever to 0 (off) position when the required speed is reached. When the retarder lever is pulled, rear brake lamps are turned on when the vehicle reaches a specified braking power. (-0.7 m/s<sup>2</sup>).

# OPERATION

## Braking

4

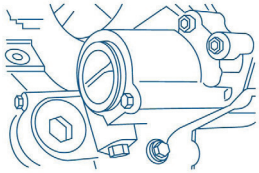

!!

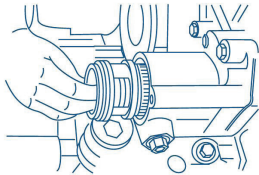

### CAUTION

Retarder requires maintenance. The oil filter should always be changed at every replacement interval of the transmission oil.



### WARNING

Retarder oil is cooled with the engine coolant. Check whether the coolant is heated excessively from the coolant temperature indicator especially when the retarder is used in long intervals.



When the coolant has reached 105 °C, retarder is deactivated automatically to prevent excessive heating of the engine.



### CAUTION

Using Retarder for any type of deceleration will extend service life of the brake linings.



### CAUTION

Do not use pressurized water to clean the retarder unit. Pressurized water may cause harm to the valves, sensors and breathers.

### Service Brakes Temperature Alert

In case of frequent use of service brakes, the yellow information lamp turns on (!) and; «Brakes overheating, reduce your speed and apply auxiliary brakes.» message along with The Brake Temperature Alert Symbol appears on the information display.

After this warning is given; the brake pedal should be pressed further in order to obtain the same amount of braking performance from the vehicle prior to the warning.

When the yellow information lamp (!) goes out, the service brake temperatures are reduced.

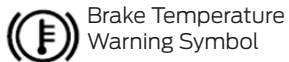

### CAUTION

Depending on the road and traffic conditions, the vehicle must be used in accordance with the following warnings, when the brake temperature alert appears:

- Reducing the speed of the vehicle
- Down shifting if necessary
- Use of auxiliary brakes primarily in situations where braking is required
- Use of service brakes only when the auxiliary brakes do not meet the need.



### WARNING

Auxiliary brakes only affect the rear wheels. Using auxiliary brakes on slippery roads and during low load operation, may lock the rear wheels and cause the trailer to fold.

Do not accelerate under these conditions by using the service brakes. Taking traffic safety into consideration, the vehicle should be used more slowly and the service brake temperature should be decreased.

# OPERATION

## Braking

### Automatic hybrid brake mode



In automatic hybrid braking mode, the retarder \* and engine brake are activated in proportion to the amount of pedal depressing, as well as the service brakes when the brake pedal is depressed. This feature can be disabled by pressing the "AUTO" button in the center console. \* Retarder is not included in the standard vehicle package, it is optional.

When the vehicle is started, automatic combined brake mode is activated. You may disable the function by pressing the "AUTO" button. Combined brake mode shall be activated when the ignition is turned off and on again.



### CAUTION

If the right multifunction lever is brought to any position other than (0), automatic hybrid brake mode is deactivated until the lever is brought to position (0) again.

### Air tubes

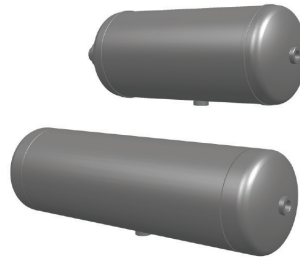

Volumes of the air tubes used in your vehicle are specified in their labels.



Drain the water in the tanks every day. Pull the ring attached to the cock until all air is discharged to drain the water inside the tanks.

When the air tanks are drained, low pressure warning should sound as the ignition is switched on. If the warning system is not operated due to a fault on the warning circuit, the fault on the system should be repaired immediately. Do not drive your vehicle until the normal pressure is displayed on the air pressure indicators. Air drier filter may be not operating if greasy mud deposit is seen during the air tank draining procedure. Replace the filter of the air dryer.

### Air Dryer (APU)

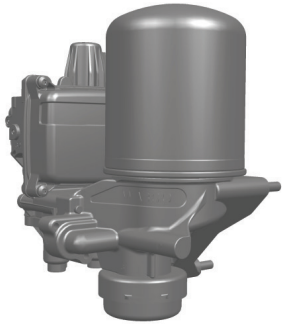

The air processing unit in your vehicle, is a unit that separates the oil inside the air, discharges the air besides the air drying function and that contains the multi-way safety valve.

Air drier filter shall be replaced in periodical maintenance intervals. If the drier filter does not operate properly, it may cause damage to itself and to the systems using air. For this reason, it shall be replaced with a filter that offers a humidity and oil trapping feature in the service.



### CAUTION

The electronic air processing unit cleans its filter at certain periods. During the cleaning process, the air level decreases and the compressor restarts. This process may be continued for several times in succession, and it is possible to drive the vehicle while the filter cleaning process is in progress.

### Auxiliary Air Line

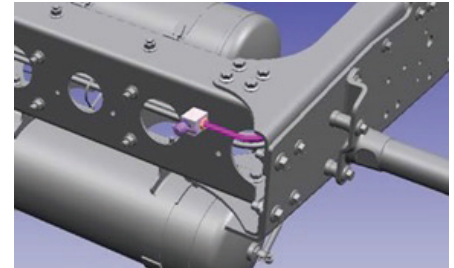

### CAUTION

 You shall not draw air directly from the tubes. When it is required to draw air for special operations, the connection shown in the figure shall be used. The pressure level here is the same as the brake pressure level displayed on the screen.

# OPERATION

## Braking

### Brake pedal test:



There are some faults that cannot be directly detected by EBS and that can be detected by monitoring the behaviour of the vehicle and the brake system only. These monitoring functions are called plausibility checks. If a plausibility error is detected by EBS, the system may be restored when the EBS performs a system test (called reverse test) according to legal requirements and the test result is positive (operation of the brake system is correct) only. This means that a reverse test is required when the cause of the fault corrected (in case of a temporary fault or when the vehicle is repaired).

In order for the EBS to perform the reverse test, the driver shall press the brake pedal once under a certain condition. When the EBS requires that the pedal shall be pressed in this way to resolve the fault, it shall send a request with the following fault code:

Path: 253 (Vehicle braking system)

Type: 201 (Request for pressing the brake pedal) (SPN 64969)

You shall press the pedal as follows:

After the detection of the fault, the ignition shall be switched off and on again to reset the EBS.

- To turn off the EBS, the ignition shall be off at least for 5 seconds and
- When the ignition is off, the brake pedal shall be released to avoid braking without resetting the EBS in waking mode.
- After the ignition is switched on, for at least 7 seconds:
- The vehicle shall remain stationary and the brake pedal shall be released.
- The EBS supply voltage shall be sufficient for electronically controlled braking.
- In case of TCM malfunctions, the parking brake shall be released.
- The warning light is on, system restriction is active.
- Pressing the brake pedal under following conditions:
- When the vehicle is stationary, a brake pedal request warning message appears on the display.
- Do not start to press the pedal within 7 seconds after the ignition is turned on.
- The pedal stroke shall be increased to the full brake position without any

conditions.

- The full braking position shall be maintained for at least 3 seconds.
- The pedal shall be released to the full release position without any conditions.
- The brake pedal shall remain in the fully released position for at least 3 seconds.
- The warning light illuminates. System restriction during braking is not active. Braking is controlled by the electronic pressure control.

### Brake pedal test successful:

- No fault is detected during braking.
- Warning lamp is off, system restriction is not active.

### Brake pedal test failed:

- When a fault is detected during braking or
- When the maximum braking period of 25 seconds has expired or
- If the car starts to move.
- The warning light remains on, system restriction is active.
- To restart the brake pedal test, the ignition shall be switched off and on again.



### Automated transmission and shifting

Ford Trucks vehicles with automated transmission are equipped with a transmission with 12 forward and 2 reverse gears; and Ford Trucks vehicles with automated Ecotorq transmission are equipped with a transmission with 16 forward and 2 reverse gears (4 reverse gears as an option). No clutch pedal is available in the vehicle. Clutch release/clutch operation is performed by the mechanism controlled by the electronic control module. System components Shift Lever:

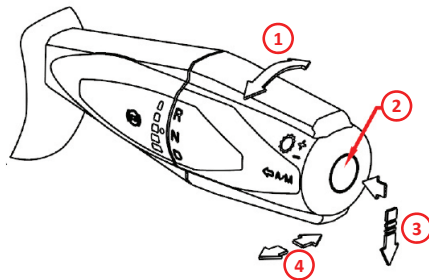

D: forward gear  
N: EMPTY  
R: Reverse  
1 Selection of driving direction

- 2 Automatic / Manual gear selection
- 3 Auxiliary brake control
- 4 Upshifting / Downshifting



### CAUTION

Operate the vehicle when the transmission is in neutral (N) and the parking brake is applied.

Do not move the shift lever in the opposite direction (D-> R; R-> D) of the movement direction or to idle position (N) while driving.

Before leaving the vehicle, bring the shift lever to (N) and apply the parking brake. Do not leave the vehicle when the gearbox is in position (D) or (R).

Press the manoeuvre button on the control panel during the parking manoeuvre.



Lock mechanism prevents switching from N to D or N to R in case of hitting the lever with your arm. This mechanism allows you to shift quickly from R to D.

### Automatic and Manual Operation:

**Automatic:** Transmission electrical control unit selects the best gear according to the engine and load status. Gear selection and shifts are performed automatically. False gear selection is not possible.

- Transmission decides the take-off gear and the gearshifts.

Transmission model code can vary according to the features such as PTO and/or retarder.

# OPERATION

## Shifting

4

- If the engine brake is not active, the transmission shall automatically switch itself to the gear with the best economy (low engine speed).
- If the engine brakes is active, the transmission shall down-shift to increase the speed.
- Clutch movement and shifts are performed automatically.
- Gears may be corrected manually.
- False gear shifting is not possible.

### First operation (taking off)

#### Moving the Vehicle

Make sure that the air is filled up. You can tell whether the air is filled or not by the air pressure section of the instrument panel. Or you may wait until the driver's seat is completely filled with air.

If the driver's seat is filled with air, this means that there is enough air for the transmission.

AL warning shall be displayed on the screen if the air in the vehicle is inadequate.



Shift to D for moving forward.

When you shift to D, the transmission shall start in automatic drive mode and shall select the starting gear itself, depending on load and inclination. D shall be displayed on the screen, indicating that the vehicle is started in automatic mode.



### WARNING

In some cases, the transmission software may not be able to calculate the starting gear (when the vehicle is started recently, when no information received or due to calculation errors). If you think that the transmission can not select the appropriate gear according to the vehicle load and the inclination of the road, you may change the take-off gear with the + and - commands on the shift knob. (Max. 6th gear may be selected for take-off)

Release the park brake and press on the accelerator slowly. Transmission shall slowly release the clutch and allow the vehicle to move.



### CAUTION

If the vehicle is on a slope when you release the park brake, it may slip backwards or forwards if you do not press the accelerator.

Keeping the vehicle uphill and slightly depressing the accelerator pedal shall cause the transmission to half-clutch, the clutch shall start to slip and it shall warm up.



CL shall be displayed on the screen if the clutch is overheated. If you see this warning, either press on the accelerator a little to allow the vehicle to move or press on the brake to hold the vehicle. Otherwise, clutch may burn out on early mileages.



### CAUTION



If you see the CW warning on the screen, this means that the clutch is worn out. Vehicle shall not move in such a case. Call the authorized service.

### Using in Manoeuvre Mode

The automatic transmission has manoeuvring modes to move the vehicle forward and backward precisely.

When in the manoeuvre mode, the transmission does not close the clutch fully or closes the clutch in a very a long time. This prevents the vehicle from moving forward abruptly and provides driving safety in approaching manoeuvres that require precise movement. Shift to D and press the manoeuvre button on the control panel to use the vehicle in forward manoeuvre mode. Shift to R and press the manoeuvre button on the control panel to use the vehicle in reverse manoeuvre mode.



### CAUTION

Manoeuvre modes are not auxiliary shift modes, they may cause damage to the clutch by overheating the clutch when the vehicle is operated under load or on a slope for a long period of time.

### Initial Movement Downhill or Uphill

-If the gear is shifted and brakes are released while the engine is operated

- If the gear is shifted to D or to the manoeuvre mode and the vehicle is downhill, transmission closes the clutch slowly and vehicle starts to move slowly.

- If the gear is shifted to R or to the manoeuvre mode and the vehicle is uphill, transmission closes the clutch slowly and vehicle starts to move backwards slowly.

### Using in Creep Mode (On vehicles with Ecotorq transmission)

Crawler mode allows the vehicle to automatically take-off slowly and move in idle without pressing the accelerator pedal.

Crawler mode may operate at each gear allowed for take-off, unless the clutch is overloaded due to the vehicle load and the inclination of the road.

You may change the gear manually before the vehicle starts to move, and thus you may set the idle movement speed as per the speed of the traffic.

When the crawler mode is set to on, it is activated after the initial take-off only.

### Driving

#### Automatic Driving Mode

Automatic transmission detects the road and load conditions and calculates and selects the appropriate gear according to the driver's pressing on the accelerator. When you think that the automatic transmission does not select the appropriate gear, you may upshift or downshift by pushing / pulling the gear lever in the + / - direction.

# OPERATION

## Shifting

4

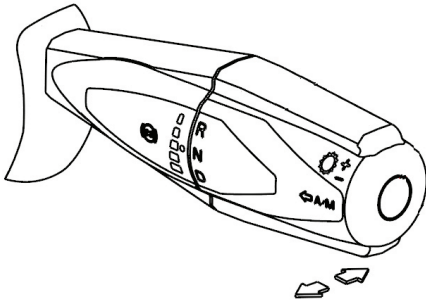

When the accelerator is pressed fully, it finds another level that can be sensed with the foot, too. If you press beyond this level, transmission downshifts for higher power and allows the engine to reach a higher speed. This feature, called as “kick-down”, helps the vehicle to accelerate while overtaking another vehicle or when power is required.

M shall be displayed on the screen temporarily if the gear is upshifted or downshifted with the gear lever. After some time, transmission shall return to automatic mode again, and D shall be displayed on the screen.

On automatic drive mode (D), the transmission adjusts the shifting speed according to the pressing level on the accelerator. Shifts gear at low speeds for economy when the accelerator is pressed lightly, and shifts gear at high speeds for performance when the accelerator is pressed strongly.

# OPERATION

## Shifting



### CAUTION



Manoeuvre modes shall only be used for coasting, and only as it is required.



### CAUTION

The duration of manoeuvre modes is limited by the transmission control unit. Maneuver mode (DM and RM) puts a strain on the clutch lining when it is used for a long time, then  warning is displayed on the display; shift the transmission to neutral and wait for a while.

### STOP

Transmission is faulty. Stop the vehicle and contact a Ford Trucks authorized dealership.

### SERVICE



Transmission is faulty.

Take the vehicle to a Ford Trucks authorized dealership in the shortest possible time.

### Manual Use:

- Take-off gear is automatically determined.
- Clutch movement and gear shifting operation are automatic when the gear is shifted manually via the shift lever.
- False gear shifting is not possible.
- Manoeuvre operation is available in automatic mode only.

If the vehicle is driven in manoeuvre mode despite the  warning on the display, transmission shifts to gear automatically. In this case, vehicle may be accelerated.



### CAUTION

Do not to exceed the maximum engine speeds allowed during manual operation.

### Display warnings:

Transmission warnings are displayed as 2 digit abbreviations on trip computer.



Transmission in neutral



Shift to neutral.

# OPERATION

## Shifting

4

**R2** Reverse, high range

**R1** Reverse, low range

**AL**  If the air pressure in the transmission air line goes below 5.8 bar, AL warning shall be displayed.

 **WARNING**

- Forcing to change gear when the air pressure is low may cause transmission to switch to neutral. In this case, exhaust brake shall not be active.
- When the air pressure drops, it is not possible to disengage the clutch.

**CL**  Clutch is overloaded.

This is displayed when you attempt to take off the vehicle with a gear higher than required in manual mode. Select a lower gear and take off the vehicle in this condition.

**CW**  Clutch lining wear

Clutch lining wear has reached limit value. Please visit a Ford Trucks authorized dealership in the shortest possible time.

**HT** 

Transmission oil temperature has reached upper limit. Stop the vehicle. Please contact a Ford Trucks authorized dealership.

### High speed drive mode

Tractor and Road series vehicles may some times require to operate continuously at high speeds. When high speed and power are required, you may turn on the power mode of the transmission, and allow the transmission to shift quicker at high speeds. To activate the power mode, press the power rocking switch on the front panel. Press on the switch again when you want to deactivate it. PWR flashes on the information display when the power mode is active.



### Off-road/rocking mode

All automatic transmission vehicles have a release function to rescue the vehicle through off-road/rocking when the traction wheels are stuck on the soft ground. To activate the off-road/rocking function, the off-road/rocking button on the front panel must be pressed for 3 seconds. When it is desired to deactivate it, it is sufficient to press the button again for 3 seconds. ROC inscription flashes on the information display while the off-road/rocking function is activated. When the off-road/rocking function is activated, differential locks are also activated automatically. After activating the off-road/rocking function, to release the vehicle, the accelerator pedal must be quickly pressed and released and the vehicle is ensured to be released back and forth.

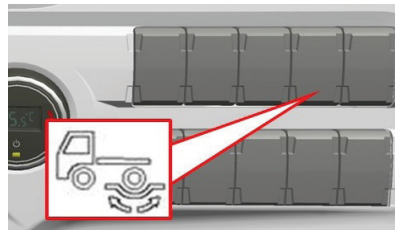

### EcoRoll mode

EcoRoll mode is a function that the driver does not press the accelerator pedal and that the transmission switches to neutral to achieve fuel economy as per the inclination of the road and the vehicle. EcoRoll mode switches off and the transmission selects the most suitable gear when the vehicle is braked, the accelerator pedal is pressed and when the vehicle moves out of a specified speed range. This function may be switched on by the driver from the instrument panel. When this function is activated while driving, the gear information shall be displayed as N besides the ROL warning on the instrument panel.

### Predictive gear selection

Predictive gear selection function receives the road information via on-board connectivity module, and allows selection of the best gear (including EcoRoll) in terms of fuel consumption and performance as per the changes on the road conditions. Predictive gear selection function does not operate during High Speed Drive and Manual Mode.

# OPERATION

## Power take off

### Power Take Off

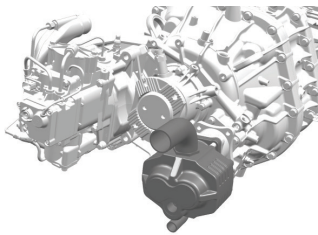

Illustration is for informational purposes only. There are no adaptors or pumps on the vehicle.

PTO is the unit connected to the transmission to operate the equipment that will be operated by taking power from the transmission (such as pumps). It transmits the power it takes from the transmission to the pump.

PTO installation is optional and can be performed on both manual and automated transmissions during production in the factory.

Contact a Ford Trucks authorized dealership for the retrospective PTO installations.

Engine electronic control unit allows that the engine is operated at a constant speed when PTO is activated. Maximum speed and function start parameters on the control unit may be set by a Ford Trucks authorized dealer.

The following preconditions shall be met for engine speed control: service. The vehicle shall be stationary, service. Transmission shall be shifted to N, service. The handbrake must be applied.

To activate the function: service. Press the “RES” button on the steering wheel, engine speed shall switch to function start speed service. When you use the “SET+” and “SET-” buttons, engine speed shall be increased and decreased with increments that may also be changed by the authorized service.

- PTO may only be activated when the vehicle is stationary and rotating knob is at position "N".
- PTO is activated by pressing the PTO button on the console.
- Shifting is not possible when PTO is activated and vehicle is moving.
- PTO cannot be activated when the vehicle is moving.
-  symbol shall be illuminated on the functions section of instrument when PTO is active.

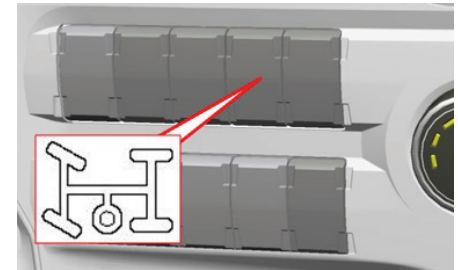



# OPERATION

## While driving

### PTO valve switch

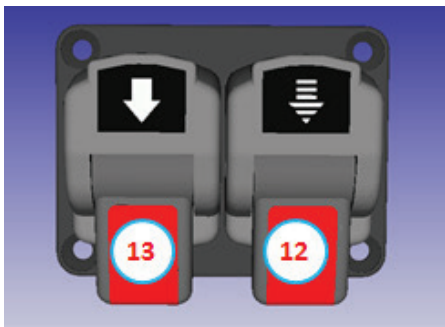

Control unit is used for lowering the bed in dump trucks. Button #12 is used for slow lowering, button #13 is used for fast lowering operation. Use the 'PTO (power take-off)' button in the panel to raise the bed.



### WARNING

The driving, braking and manouvering behaviour of the vehicle varies according to the type, weight of the load, and the location of the center of gravity. Make sure that the vehicle is loaded in a balanced way and avoid an unbalanced distribution of load.

Secure the load to prevent sliding when required. Otherwise, you may loose the control of the vehicle and cause an accident.



### CAUTION

Observe the allowed axle loads, wheel loads (half of the axle load) and maximum total weight of the vehicle. Otherwise, damage to the tires, chassis and axles may occur. Observe the indicators on the instrument panel while driving.



### WARNING

Make sure that the driven wheels are held on the road while driving, and especially on the off-road. Prevent the spinning of the driven wheels (Differential damages). Activate the differential lock.



### CAUTION

Driving the too much off-road may cause damage to the vehicle. The obstacles may not be noticed in time and the structure of the ground may not be assessed properly.

E.g. deep tracks formed before may damage:

- Axles
- Driveshafts
- Fuel tanks
- Compressed air tank
- Engine
- Transmission.

Therefore, always drive slowly off-road. If you shall drive over the obstacles, co-driver shall provide directions.

Always observe the height of the vehicle from the ground. Avoid obstacles whenever possible.

# OPERATION

## While driving

4



### WARNING

In the vehicles with engine driven power output (Engine-PTO), the angle of the shaft mounted at this point by the superstructure manufacturer with respect to engine shall not exceed the value of 3°. Make sure that the superstructure of your vehicle was constructed accordingly. Otherwise, it may result in vibration, balance and thus serious engine and superstructure problems.



### CAUTION

You may not observe the obstacles in time or assess the structure of the ground properly. Always drive slowly off-road to prevent damages to the vehicle. Vehicle may slip sideways or turned over. Never drive the vehicle in direct angle to the slope, always drive in parallel to the slope. Do not manoeuvre in the opposite direction. If your vehicle cannot take a slope, drive in the reverse gear. You may lose the control of the vehicle when you shift to neutral or press the clutch or try to brake the vehicle with the service brake only in slopes. Do not let your vehicle to move in neutral or with the clutch activated.

If you load your vehicle excessively, this would increase the risk of turning over. Do not exceed the maximum permissible axle load. Maintain the center of gravity as low as possible when you are loading your vehicle. Materials that lower that the effect of braking, such as sand or water mixed with oil, may enter the brakes if you drive your vehicle on muddy or swampy areas frequently. This may cause excessive wear and a decrease in the braking effect. A risk of not being able to use the braking effect fully in emergency conditions is present. Test the brakes after any off-road drives. If the braking effect is lowered or that rubbing noises are present in this test, make sure that your brake system is checked by a FORD OTOSAN authorized dealership.



### WARNING

Acceleration forces act on your body from all directions due to the improper nature of the ground. There is a risk of bouncing off the seat and injuring yourself. Always fasten your safety belt in the off-road drives, too.

Drive systems for off-road trips. Driving systems and equipment described below allows you to drive your vehicle safely off-road:

- Disengagement of the ASR.
- Differential locks.



### WARNING

The steering wheel may strike back and cause injuries on the thumbs of your hands when driving over obstacles or the tracks formed over the road. Hold the steering wheel tightly with your both hands. Consider the high forces occurring for a short period of time while driving over the obstacles.

- Stop the vehicle and engage a lower gear before driving off-road.
- Always drive the vehicle with the engine running and a gear engaged while driving off-road.
- Drive slowly and with a stable speed. Drive with the crawling speed if required.
- Make sure that the wheels are always held on the road.
- Activate the differential lock.
- Drive with extra care in an unknown or a non-visible area. Get off the vehicle first, and inspect the terrain for safety reasons.

- Check the depth of the water before driving through the water.
- Observe the obstacles like rocks, holes, trunks and trenches.
- Avoid skirts of the ground that the ground may be torn.

### Before driving off-road

- Engagement of the differential lock
- Disengagement of the anti-skid control
- Equipment specified below should be available on the vehicle:
- Shovel
- Climbing rope with bolted Y anchor.

### After driving off-road



#### WARNING

Faults caused by off-road driving may cause accidents or prevent some parts from operating. Clean and check your vehicle after driving off-road. Have the fault repaired before next operation of the vehicle.

- Disengage the differential lock
- Engage the anti-skid control (ASR)
- Clean the vehicle
- Check the vehicle for any damage.

### Fuel consumption varies according to

Fuel consumption depends on the conditions below:

- Model of the vehicle
- Driving style
- Operating conditions
- Tire dimensions, tire profile, tire pressure, condition of the tires
- Upper structure, air deflector
- Drive train for the drive applications
- Auxiliary applications (A/C and heater, auxiliary power outlet, viscous fan)

Fuel consumption information may be displayed on the standard on-board computer.

### Driving style

- To lower the fuel consumption:
- Avoid frequent acceleration and braking
- Drive carefully by paying attention on the road
- Drive within the economic engine speed limits

### Workstations

It is not possible to provide a certain value for the fuel consumption of the vehicles operating under the following conditions:

- Highland conditions
- Traffic in cities and short distances
- Vehicle load
- Operation while the vehicle is parked
- Frequent starting when the engine is cold



#### CAUTION

Stop lamps may flash quickly to warn the vehicles behind in case of harsh braking. Then the flashers may turn on after the vehicle has stopped.

# OPERATION

## ECAS (Electronically Controlled Air Suspension)

### Manual Control Unit (On Vehicles with Air Suspension)

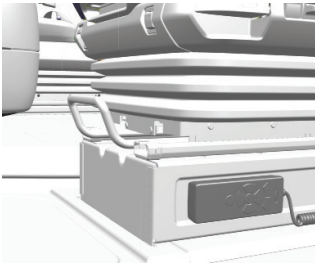

Chassis height of the vehicles with air bellows on rear axle may be adjusted by the control.

ECAS control is fixed to the metal surface on the lower left of the driver's seat with a magnet.



### WARNING

⚠ Do not change the chassis height of your vehicle by the manual control unit when driving. Use the manual control unit when your vehicle is stationary and parking brake is applied. This is important for the safety of you and your vehicle.

⚠ If the vehicle air pressure is below 7 bar, ECAS shall not operate

### Using the Manual Control Unit

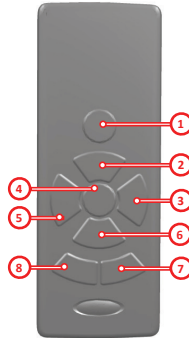

- 1 - Stopping button (STOP)
- 2 - Lifting button
- 3 - Axle selection button (right)
- 4 - Normal drive height button
- 5 - Axle selection button (left)
- 6 - Lowering button
- 7 - M2 memory button
- 8 - M1 memory button

⚠ As the rear surface of the control is magnetized, it shall not be used in areas with metal burrs or where there is a risk of scratching without being cleaned after being used.

1. Ignition switch should be in position **2** to activate the air control system by the "manual control unit".
2. Drive axle selection is performed by using buttons no. 3 or 5. Axle selection may be activated or deactivated using the right or left arrows. Illumination shall be active as per the axle on the vehicle when the axle is selected. Control functions shall be available after performing this selection. You bring the vehicle to the desired height using the up, down and driving height buttons after this time.
3. Press the "STOP" button if you need to stop the operation during any procedure.
4. If you want to record a certain chassis height, press the "STOP+M1 or M2" buttons for 2 seconds at the same time. This would record the height to the system. In the future, when you want to adjust the vehicle to this height, use M1 or M2 buttons.



The symbol is illuminated on the instrument when the vehicle is not at driving height.

## ECAS (Electronically Controlled Air Suspension)

### ECAS indicator interface

Axle weight information shows the most correct information when the vehicle is at driving height.

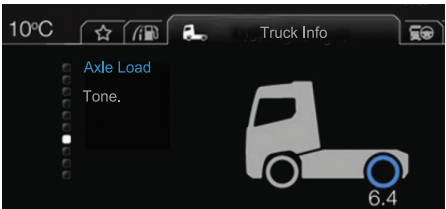

If the lights of the ECAS control are not illuminated or it does not work, you may use the level adjustment function on the indicator until you drive to the service.

To use the ECAS adjustment function on the indicator;

1. Enter the ECAS adjustment screen using the direction
2. Press the OK button to enter the adjustment screen.
3. Press OK button again to bring the vehicle back to the driving height.
4. Use navigation keys to select raise or lower height expressions and keep "OK" key pressed to move the vehicle up or

down. These functions lower or raise the vehicle while the keys are pressed as it is in the control.



5. Check the warning colour when "ECAS warning active" message is displayed on the Display Screen. Error is critical and no ECAS function shall operate if the red warning is active. ECAS functions resume to operate manually or as limited as per the status of the error if the yellow warning is active. However, we recommend you to drive to the authorized service in both cases.



### Front Axle Height Adjustment Mechanism



Front axle lifting system shall be deactivated when the ignition is switched off and vehicle shall be lowered to drive level. In this case, use care for the relationship of the parts of the vehicle approaching the ground with the surroundings.

Front axle lifting system shall be deactivated when 30 km/h speed is exceeded and the vehicle shall automatically be adjusted to driving height.

### Operating Instructions for Front Axle Height Adjustment Mechanism (Only for Vehicles that the height of the 5th wheel is lowered)

Ignition switch should be in position 2 to activate the air control system by the "Lifting Switch".

When the front axle lifting switch  is pressed, front suspension bellows start to raise the front chassis of the vehicle. While the system is active, on vehicles with Manual transmission: An audible warning signal with a gong sound is heard. On vehicles with an automatic transmission: An audible warning signal with a gong sound is heard and  symbol is displayed on the indicators.

When the rear axle lowered drive level control button  is pressed,  symbol is displayed on the indicator.

Allows lowering of the rear axle that is taken to the drive level in manual control to lower the level of the 5th.

# OPERATION

## EBS-ESP

4



### CAUTION

ESP is an auxiliary brake system. Always remember that no system can change the physical laws. Driving safety is responsibility of the driver despite all auxiliary systems.

### EBS (Electronic Brake System)

EBS (Electronic Brake System) is an integrated braking system that includes sub-systems.

#### 1-Braking power control:

EBS control unit adjusts the braking power on the wheels automatically based on the information from the load sensor and the brake pedal travel applied by the driver.

**2-Automatic braking power distribution between axles:** EBS adjusts the braking power that will be applied to the axles based on the axle load.

#### 3- ABS:

ABS maintains steering control by preventing the locking of wheels during brakes.

#### 4-Automatic Traction Control:

Main purpose of this function is to prevent skidding of driven axle wheels.

a) Braking power control: The speeds of the wheels of the driven axle are equalized by decelerating the skidding wheel by braking.

b) engine torque is automatically limited to ensure that the vehicle moves stably.

#### 5-Inertia torque control:

Wheels may skid due to the engine inertia in slippery surfaces. Especially, when the transmission is downshifted and/or retarder is activated, wheels may have an inclination to skid.

Inertia torque control system sends a signal to engine control unit and adjusts the engine torque to overcome the inertia of the engine.



### CAUTION

Retarder may cause the vehicle to skid in slippery road conditions.

#### 6- Emergency brake assist system:

System senses the braking operation and increases braking power according to the pedal travel.



### CAUTION

Emergency brake assist cannot increase the maximum capacity of braking power. Vehicle shall be braked in the limits of maximum braking power.

**7-Tilt prevention system:** System senses the risk of tilting automatically when the brake is applied and decreases the braking power of front wheels and increases the braking power of rear axle. Thus, vehicle is prevented from tilting.

### ESP Deactivation Mode:

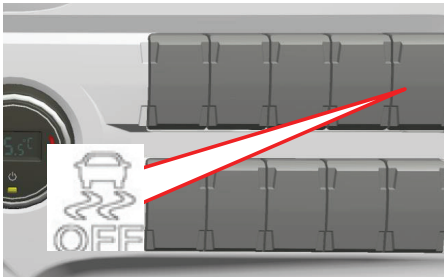

You may want to disable ESP on soft road conditions. In this case, press the ESP cancel switch located in the centre console.



light is illuminated on the display when this mode is active.

# OPERATION

## Differential Lock

### What is differential lock?

Differential lock is a system that increases the capacity of transmission of power to the surface. Lock gear is consists of the yoke that moves the gear and an air operated piston.

### When the differential lock is engaged,

Engine torque transmitted to the left and right sides of the vehicle and wheel speeds are equalized. Activate the differential lock in bad and slippery road conditions where high and stable traction power is required.

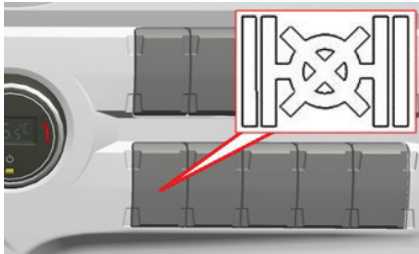

### Engagement of the differential lock

1) Activate the differential lock before running into worsening road conditions. Ensure that the road conditions are not slippery or any wheel is not slipping or skidding while it is being engaged.

Ensure that the wheels are not on slippery surface first and stop the vehicle completely.

2) Engage the differential lock button on the center console.

3) Differential lock light  shall be illuminated on the instrument panel when differential lock is activated, and a warning buzzer shall sound if available.



### CAUTION

If the differential lock is not used properly, there is a risk of heavy damage to the differential unit and/or a serious risk of accident. Differential faults caused by using improper use of differential lock are out of warranty cover.



### The points to be considered when the differential lock is activated:

The points to be considered when the differential lock is activated:  
If required, the differential lock shall be engaged prior to go through the rough surface at the required distance and its engagement and disengagement shall be monitored via the illuminated warning sign on the instrument cluster.

Vehicle may move outward of the curve in turns while the DCDL is completely activated.

Do not use differential lock on paved roads, and never perform turns when the locks are engaged.

When turning, make sure the differential lock is disengaged. Otherwise the differential of your vehicle may be damaged severely and you may have to call for AAA.

The maximum speed shall be 20 km/h when differential lock is engaged.

### Deactivating the differential lock:

- 1) When it is safer to drive above certain speeds as soon as road conditions become normal, differential lock must be deactivated.  
Vehicle shall be stopped and differential lock shall be disengaged after making sure that the vehicle moved far away from the slippery surface.  
Ensure that the wheels are not on slippery surface first and stop the vehicle completely.
- 2) Deactivation of the differential lock is performed when the warning light on the instrument panel is turned off and this may take about 500 meters sometimes.  
Turn the differential lock switch(es) on.  
Drive the vehicle very slowly by applying the accelerator slowly to deactivate the differential lock.
- 3) The differential lock will disengage once the illuminated warning sign on the instrument cluster and the warning buzzer, if any, will stop.

- 4) You can continue driving observing the legal speed limits according to flow of the traffic.



### WARNING

Vehicle should always be decelerated in sharp curves, and it is advised that the the differential lock is deactivated in sharp curves. User is informed by buzzer on that differential lock is activated.



### CAUTION

Deactivate the differential lock when driving the tractor vehicles down the slopes. Trailer may be folded due to the loss of the vehicle dynamics.

# OPERATION

## Lane Departure Warning System

### WARNING

△ Lane Departure Warning System is just a warning system and does not interfere with the vehicle dynamics. Always use your vehicle carefully and do not test the system on the road.

△ System shall not warn you if the hazard flashers are active.

△ System shall not warn you when the Lane Departure Warning Lamp  is illuminated solidly. Solid illumination of the warning lamp indicates a system fault or that the system is turned off by the driver.

△ Always activate the turn signal at the direction that you are leaving the lane, so that you do not receive a lane departure warning while changing lanes actively.

△ The Lane Departure Warning System does not mitigate your responsibility to use the car carefully and attentively.

△ The driver shall have the vehicle under control always and at all times. It is the driver's responsibility to intervene or disable the system when required. Sensor may follow the lanes incorrectly, and may mistake them for other structures and objects. In such a case, the system may give false or incomplete warnings.

### WARNING

△ The system may not work under bad weather conditions. Rain, snow, liquids splashing on the windshield, dirty or worn lane lines, and high contrast of the lighting may adversely affect the operation of the sensor.

△ The system may not work in areas where the road is under construction.

△ The system may not work in sharp bends and narrow lanes.

△ Do not repair the windscreen on the areas near the camera sensor.

△ The system may not work properly in the following situations:

- If the lane lines are not regular
- When the lights of the oncoming vehicles, the sunlight or the lights reflected from the wet surfaces come directly to the sensor
- If the lighting on the road is insufficient, or in case of snow, rain, fog or water splashes to the windshield
- If the lane lines are not detected when the distance from the vehicle in front is small.

- If the area where the camera is located on the windshield is dirty, fogged, damaged or covered by any object
- If there are no lane lines on the road or if there are multiple lane lines

**Note:** The system shall be activated when the vehicle speed is 60km/h or above.

**Note:** The system may only work when at least a lane is detected and followed.

### Operating principle

The sensor of the Lane Departure Warning System located behind the windshield, on the lower center area of the windshield. When active, the system constantly monitors the road and driving conditions, warning the driver at high speeds when the vehicle inadvertently exits the lane. If the vehicle is moving above a speed of 60 km/h and there are visible lane lines on both sides of the road, lanes lines that indicate that the system is and ready to provide warning shall appear on the information display, on the area separated for the Lane Departure Warning System.

## Lane Departure Warning System



Lane Departure Warning System icon on the Information display

Lane departure warnings are given audibly and visually. The audible warning is issued directionally either from the right or left to indicate the direction from which the vehicle leaves the lane inadvertently. In order to increase the audibility of the audible warning, the radio is muted and the fans of the air conditioning system are automatically switched off during the warning.

Once the system provides a warning, the vehicle shall return completely to the lane so that a second warning may be given.

### Switching the System On and Off

**Note:** When the ignition is turned on, the system shall be activated automatically as long as there is no fault. To turn off the system, press the off button. The system shall be turned off and the warning lamp on the instrument panel shall be lit solidly. To turn the system on, press the Lane Departure Warning System button again

and make sure that the warning light on the instrument panel is turned off.

**Note:** The system is only designed to provide warnings on inadvertent lane departures.

The attention of the driver is determined by evaluating a number of entries listed below. If these inputs clearly indicate that the driver is using the vehicle actively, the system shall not provide a warning.

- Lane departure speed
- Use of brake pedal
- Activation of the turn signal on the side that the vehicle comes out of the lane
- Activation of the hazard warning flashers

**Note:** If the right/left turn signals are active for longer than one minute, these signals shall not prevent the system from giving a warning.

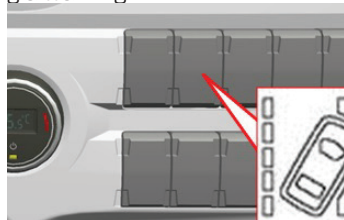

Lane Departure Warning System on/off button



Lane Departure Warning System warning lamp

**Note:** When the camera's view is blocked, the following message shall appear on the instrument panel.



When the above message is displayed:

- If camera vision is blocked due to heavy snow or rain, the shall be operated at the proper speed or the automatic wiper function shall be activated. If the windshield is dirty, the windshield washer shall be activated and the dirt shall be removed.

# OPERATION

## Emergency braking system

- If there is mist on the windshield, operate the ventilation or the windshield heating function to remove the mist.

**Note:** The system may be deactivated if the camera's view is blocked. In such a case, the Lane Departure Warning System warning lamp shall be lit solidly.



**Note:** If you see the following warning on the instrument panel, you shall take your vehicle to a Ford Authorized service. The Lane Departure Warning System shall not be active until the vehicle is inspected by the service.

**Note:** If the warning light is illuminated solidly for a long time, there may have been an error in the system that would have caused the Lane Departure Warning System to turn off.

## Emergency braking system

### Emergency braking system

If your vehicle is approaching a stationary vehicle or another vehicle that is moving in the same direction as you and the Emergency Braking System detects the possibility of a rear-end collision with the motor vehicle in front of you, system offers functionalities with the two levels specified below:

1. Collision warning
2. Emergency braking

**Collision Warning:** If the system detects that a collision is possible, the warning lamps  starts flashing, an intermittent warning buzzer is heard, and a collision warning is displayed on the screen. In order to increase the audibility of the audible warning, the radio is muted and the fans of the air conditioning system are automatically switched off during the warning. If the system detects that you have not taken control of your vehicle to prevent a collision and if it is still possible to determine that a collision is possible, the system may start partial braking to warn you and continues to provide collision warnings.

**Emergency Braking:** If the system continues to detect that you have not the control of vehicle to avoid any crash and is still capable of detecting any possibility of crash, the system may perform full braking to reduce the intensity of crash or to avoid crash completely and keeps giving warning to draw your attention.

Emergency braking system is active at speeds above 15 km/h approximately.

The Emergency Braking System does not become activated when the speed difference between you and the vehicle ahead of you is less than 10 km/h.

### WARNING

Switching off the ESP function shall also cause the Emergency Braking System to turn off automatically.

The fact that the Emergency Braking System warning lamp  is lit solidly indicates that the system has been shut down by the driver or that the system has shut down due to a fault. In such a case, the system is turned off. It shall not warn you and shall not apply the brakes.

### WARNING

 A collision warning indicates that a possible collision is determined by the system. If you get this warning, always apply the brake yourself and make the necessary manoeuvres to prevent the collision, if required. Failure to observe this may result in loss of control, serious injuries or death.

### WARNING

 The Emergency Braking System is a collision avoidance system; however the system may never replace safe and careful driving. The system works within certain limits for certain traffic scenarios only. The system may not work as expected in all conditions and circumstances. The system certainly does not remove your responsibility to use your car safely and carefully. Failure to observe this warning may result in loss of control, serious injuries or death.

 The system cannot predict what other drivers in the traffic will do. Always leave a safe distance with the vehicle in front of you while driving. Failure to observe this warning may result in loss of control, serious injuries or death.

# OPERATION

## Emergency braking system

4

⚠ The system is designed to provide active driver support only to prevent a possible frontal collision or to reduce the severity of the collision under real traffic conditions.

⚠ The system may not always detect the possibility of collision and/or may not be able to prevent the collision even if it detects it. The system is not designed to prevent all kinds of collisions or to detect complex traffic conditions. Careful driving is always the responsibility of the driver. Always use your vehicle with caution and be ready to apply the brakes. Failure to observe this warning may result in loss of control, serious injuries or death.



### CAUTION

⚠ The system does not respond to bicycles, motorcycles, pedestrians, animals, or vehicles moving in a different direction. Failure to observe this may result in loss of control, serious injuries or death.

⚠ The system is not designed to prevent accidents that may occur with stationary vehicles. The system may only reduce the severity of rear-end collisions that may occur with stationary vehicles under certain circumstances only.

⚠ The system may not work while taking sharp turns.

Failure to observe this may result in accidents or personal injury.

⚠ Under cold or harsh conditions, the system may not operate or may operate with low performance. Snow, ice, rain, water and fog that splashes from the wheels of the vehicle in front of you or from the road in extreme amounts can adversely affect the operation of the system. Failure to observe this may result in loss of control, serious injuries or death.

⚠ If you replace the windshield with a windshield that is not produced by Ford, the system may not work correctly. Do not perform windshield repairs in the areas in front of the camera sensor. Failure to observe this warning may result in accidents or injuries.

⚠ System may not detect objects with surfaces that absorb reflections. Failure to observe this may result in loss of control, serious injuries or death.

⚠ System performance may be deteriorated if the camera sensor's sensing capability is limited. For example, direct sunlight that dazzles the eyes, inadequate sunlight, vehicles with rear stop lights that do not work at night time, narrow vehicles and unusual vehicle types may not be detected by the system. Do not drive recklessly relying on the system

and always pay attention to your speed and your distance from the car in front.

⚠ The effectiveness of the system vary depending on the speed, driver inputs, heavy rainfall, the behaviour of the vehicle in front of you, your vehicle's condition and road conditions.

⚠ If you do not have the periodical maintenances of your vehicle performed by Ford authorized services, the system may not work correctly.

⚠ If your vehicle shall be towed by another vehicle, turn off the system by pressing the off  button. If your vehicle is towed while the system is on, the system may cause your vehicle to provide warnings or to brake unexpectedly.

⚠ While driving your vehicle in terrain conditions, you shall turn off the system by pressing the off  button. **How shall the driver maintain the system under normal operation conditions?**

**Note:** If you receive a warning that the radar sensor is blocked on the information display, this means that the radar signals are blocked. The radar sensor is located behind the flat surface in the lower center area of the top grill as shown below. If the radar is blocked, the emergency braking system shall not operate and detect the vehicle in front.

## Emergency braking system



Radar sensor blockage warning

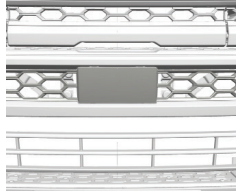

Radar and the flat surface in front of it

**Note:** It is the driver's responsibility that the radar sensor and the flat surface in front of it are clear and clean. Make sure there are no mud, heavy snow or any foreign objects on the front surface of the radar sensor and on the flat surface in front of the radar.

**Note:** Do not have any attachments installed to the front of the radar on your vehicle. The flat surface in front of the radar shall not be covered or painted. Any changes to the radar surface or the flat surface in front of it may cause the Emergency Braking System to malfunction or may reduce the functionality of the system.

**Note:** If the front of your vehicle is struck by an object or if the front of your vehicle is damaged, the radar vision setting may be impaired. This may cause the system to give false warnings or no warning at all. In order to ensure that the radar is working properly and to check the coverage area, you may contact a Ford Authorized Service Station

**Note:** If you see a warning about the "low front camera resolution" on the information display as follows, this means that the camera's view is blocked. Blocking of the camera view may cause the Emergency Braking System to lose its functionality or the may cause the system to turn off completely.



Camera sensor blockage warning

**Note:** The camera sensor is located in the lower center area of the windshield. If you see the warning above, clean the outside of the windshield in front of the camera by activating the windshield washer.

**Note:** Do not attach a sticker or a film on the part of the windshield in front of the camera to prevent the sunlight.

**Note:** Repair windshield damage in the camera's field of view.

### What to do When a Trailer is Connected to the Vehicle



#### CAUTION

**After you have connected a trailer to the vehicle and made sure that all the electrical connections between the trailer and the vehicle are made, if the ignition is still on, close and open the ignition completely. Otherwise, your vehicle's brake system and Emergency Braking System may not work properly.**

**⚠** Emergency braking system shall automatically shut down if there is a fault in the brake system of the trailer or if the trailer you have connected to the vehicle is not equipped with an ABS feature.

# OPERATION

## Emergency braking system

△ Emergency braking system is designed with the assumption that it shall be connected to one trailer maximum. If more than one trailer is connected, the system shall be turned off by pressing the off  button.



### Switching the System Off and On

**Note:** The Emergency Braking System shall be on whenever the ignition is switched on as long as there is no fault in the system.

**Note:** To turn off the system, press

the system off  button on the front

panel. The system warning lamp  on the instrument panel shall be lit solidly when the system is turned off. To turn the system back on, press the system off

 button for a little while. In this case, warning lamp  shall be turned off to indicate that the system is active again.

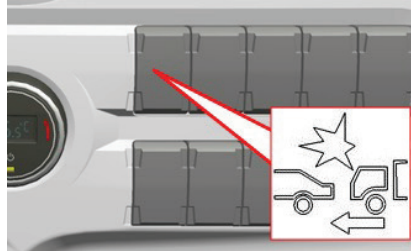

Emergency Braking System off button

### Why may the Emergency Braking System be turned off?

- You may have turned the system off by pressing the off  key.
- ESP function may have turned off.
- The system may have detected that the radar detection area setting has failed. In this case, the information screen shall display a warning that the system has failed. Your vehicle shall be inspected by a Ford Authorized Service to have the system activated again.

- The system may have turned itself off considering the possibility of a problem in the system if the system has switched over twice before the ignition is switched off. Your vehicle shall be inspected by a Ford Authorized Service to have the system activated again.



Emergency Braking System malfunction warning

**Note:** Faults in other systems or parts of the vehicle may cause the Emergency Braking System to turn off automatically. If the system warning lamp  has been lit solidly for a long time, your vehicle shall be inspected by a Ford Authorized Service.



## Emergency braking system

### How may the intervention of the emergency braking system be suppressed?



#### WARNING

The Emergency Brake System may warn you and brake your vehicle even if the traffic situation is not critical. Be prepared to suppress the system. You may stop the current Emergency Braking System warnings or suppress warnings that have not started yet by conducting one of the following actions:

- By signalling to left or right
- By pressing the brake pedal
- By pressing the accelerator pedal
- By pressing the system off  button

You may cancel an emergency braking operation that is triggered by the Emergency Braking System with one of the following actions:

- By pressing the accelerator pedal fully, and activating the button at the end of the pedal
  - By pressing the system off  button
- If you are stopped by an emergency braking operation triggered by the

Emergency Braking System, the system shall hold the brakes until you suppress the system with one of the following actions. To release the brakes in such a case:

- Depress the accelerator pedal.
- or
- Press the system off  button.



#### CAUTION

**Important Note:** In such a case, gain the control of your vehicle and make sure that you apply the parking brake before you leave the vehicle. Before leaving your vehicle, take all safety precautions to protect your vehicle and yourself.

# OPERATION

## Driver evaluation function

### Driver Evaluation

This function allows evaluation of the drivers by analysing all data based on driving experience.

Its aim is to ensure fuel economy by the driver while driving and to provide concrete results based on score by evaluating various driving characteristics of the driver. Driver Evaluation function may be used by selecting the driving evaluation option under the “driver assistance” menu.

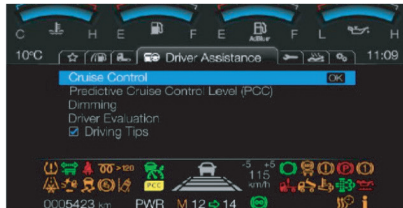

Driver Evaluation function scores the driver by his/her acceleration, anticipation, deceleration and driving scores as per his/her fuel consumption.

Driver shall cover some mileage to start the evaluation process. Evaluation results shall be submitted to the driver after collecting adequate amount of data\*. Driver evaluation starts with 80 points and the average score is displayed by scoring as per the driving characteristics of the driver. While aggressive driving in

the course of driving costs points for the driver, proper actions for driving shall bring points.

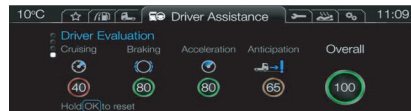

The screen shown above is an example of the driver evaluation screen.

\*Driver shall not be able to display any digital data on the screen until adequate amount of data is collected.

Scores displayed may be reset by pressing the “OK” key for 4 seconds whenever desired by the driver.



### Accelerate

Acceleration score is calculated as per the pedal travel on the accelerator pedal while driving and as per the engine speed of the vehicle. Aggressive operation of the accelerator by the driver, rapid accelerations and acceleration for a long period shall reduce the acceleration score.

### Deceleration

Frequency of the operation of the brake pedal and pedal travel on the brake pedal are amongst the factors that affect the deceleration score. Using auxiliary brakes, avoiding abrupt braking and frequent brakes shall bring a successful braking score.

### Driving

This is evaluated by the operation of the vehicle in fixed speed. Moreover, operation of Max Cruise and Cruise Control has a positive effect on the driving score of the driver.

### Anticipation

This is evaluated by the use of the distance that occur by acceleration and deceleration of the vehicle during driving by the driver. If the vehicle is allowed to move without using the accelerator and brake pedals and the distance with the vehicle ahead is kept stable, the anticipation score shall be successful.

### General

Average value for all driving parameters is displayed in this field.

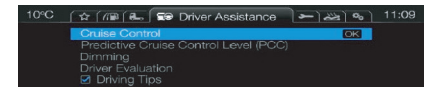

Driving Tips are active on the image above.

# OPERATION

## Accessories

### Coffee Maker

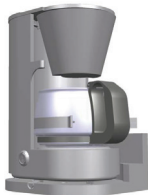

User manual of the coffee maker is delivered with the product. Please read the user manual carefully before starting to use the coffee maker.



#### CAUTION

The position shown in the figure is designed to secure the product when it is not being used, and it shall be installed by an authorized service.

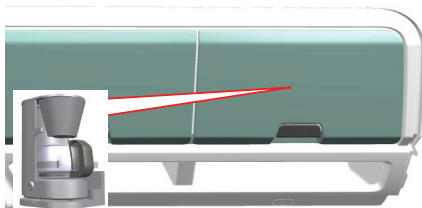

### Refrigerator



User manual of the refrigerator is delivered with the product. Please read the user manual carefully before starting to use the refrigerator.



#### CAUTION

If you want to install a refrigerator on vehicles that are not equipped with a refrigerator ex-factory, you shall have the product installed by an authorized service.



**Do not step on the refrigerator**

### Headlamp guard grill

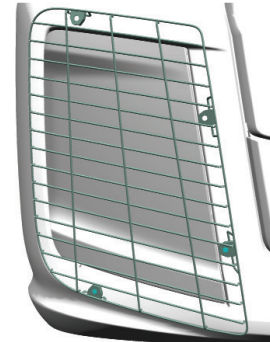

The Headlamp Guard Grill may be purchased from the services as an accessory for your vehicle.



#### CAUTION

The product shall be installed by an authorized service.

# OPERATION

## Useful Information

4

### **CAUTION !**

**YOUR TACHOGRAPH IS NOT CALIBRATED.  
PLEASE HAVE YOUR TACHOGRAPH CALIBRATED IN AN  
APPROVED SERVICE SPECIFIED IN THE  
MANUAL PROVIDED.**

- You have made a right choice by purchasing a Ford Truck. Congratulations.
- Please consider the following points and read this manual to obtain best performance and service life from your vehicle.

### 1. Air and oil filters

- Replace the air filter element when air filter warning light is illuminated inside the cab. Always refer to the warranty and service manuals for the main filter element replacement intervals.
- Use oil and air filters approved by Ford Otomotiv Sanayi only.

### 2. Adding oil

- Do not add oil until the oil level is reduced to min. line.
- Never add oil over the max. line.
- Add oil to the engine when the oil level warning light is illuminated.

### 3. Engine

- Your vehicle is equipped with a system that prevents starting of the engine while transmission is shifted to a gear.
- Always observe starting instructions provided in the manual.
- Do not increase the engine speed until oil pressure is increased after starting.
- We advise you to operate your vehicle in the green zone tachometer to obtain best traction. (1050 to 1600 rpm)
- Operate your engine at idle for 1 minutes before stopping the engine in order to allow continued lubrication of the turbocharger unit.
- We advise you to use the vehicles with automated transmissions in automatic mode as much as possible.

### 4. Injector pump

- Injector pump available in your vehicle is completely adjusted and sealed in factory.
- Do not let tampering of injector pump by any other workshops other than authorized dealerships.

### 5. Wheel nuts

- Have the wheel nuts tightened to the specified torque values after 500 km from the first loading point of your vehicle. This operation should be repeated after each nut removal. (750 +/- 50Nm)

### 6. Wheel alignment

- Have the front alignment adjustment of your vehicle checked, and have it adjusted by service support if needed in the first 1000 to 5000 km.

# OPERATION

## Useful Information

4

### 7. Braking system

- Drain the water in the air tanks every day.

### 8. Differential lock

- Contact authorized dealership when the differential lock warning lamps is illuminated while the differential lock switch is not pressed. The maximum speed shall be 20 km/h when differential lock is engaged.

### 9. Cab lift

- Ensure that park brake is applied, transmission is in neutral and hood is open before lifting the cab.

### 10. Upper bed

- Do not lower the upper bed while the vehicle is moving.

### 11. Refuelling

- Turn off the auxiliary cab heater before refilling fuel.

### 12. Tyre pressures

- Your vehicle is provided with low tire pressures from the factory. Adjust tire pressures according to the tire pressure values given in the manual before first loading.

### Authorized dealerships

Have your vehicle maintained and repaired by our dealerships available countrywide and using genuine Ford spare parts. We wish you a safe trip and a prosperous business!

# MAINTENANCE AND SERVICE



# MAINTENANCE AND SERVICE

## Attaching and Detaching a Trailer

### 5. Wheel (Platform) - Trailer Connection (for 5th wheels of SAF HOLLAND brand)

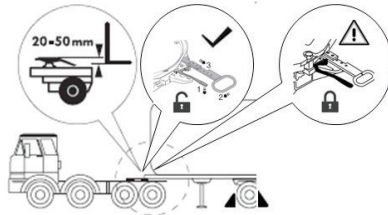

Figure-1

1- Block the wheels of the semi-trailer.  
2- Check that 5th wheel lock is open. The port for the semi-trailer pin should be open. (see Figure 1)

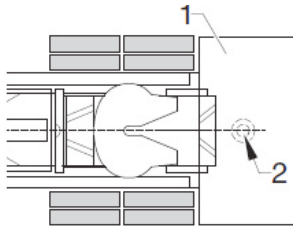

Figure-2

3- Position the truck in front of the semi-trailer. (see Figure 1 and Figure 2)

4- Position the vehicle so that there is a clearance of 20 to 50 mm between the bottom of the semi-trailer and the 5th wheel platform (see Figure 1)

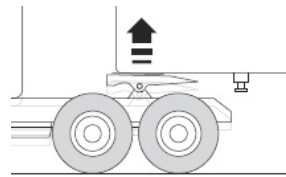

Figure-3

5- Lift 5th wheel with the help of the air suspension until the semi-trailer is slightly raised. (see Figure 3)

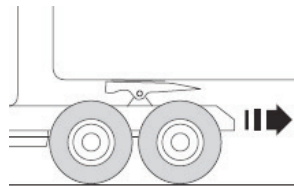

Figure-4

6- Reverse the vehicle slowly until 5th wheel coupling engages. (see Figure 4) The spring safety lever should return to its original position automatically. (see Figure 5)

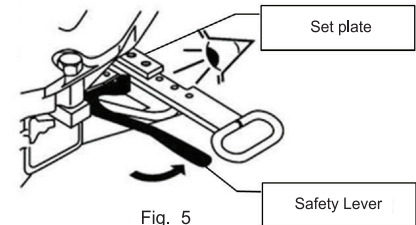

Fig. 5

7- Get off the vehicle and visually check that 5th wheel lock has fully engaged. If the lock is fully closed, the safety lever should be in the upper position and the small adjustment plate on the lock lever should contact 5th wheel platform. (see Figure 5 and Figure 6).

As shown in Figure 6, the latch on the safety lever should be in the upper position.

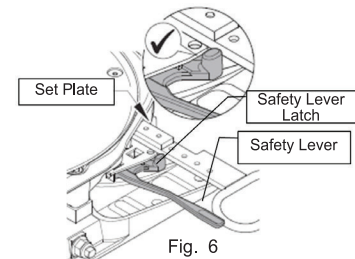

Fig. 6



# MAINTENANCE AND SERVICE

## Attaching and Detaching a Trailer

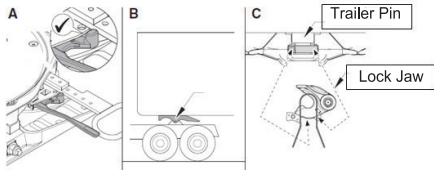

Fig. 7

8- As shown in Figure 7, carry out the visual check for fully locking in order (A, B, C).

**Check A:** Check the safety lever, the latch on the safety lever and the adjustment plate. The safety lever and the latch on the safety lever should be in the position shown in Figure 7-A.

**Check B:** There should be no gap between the semi-trailer and 5th wheel.

**Check C:** The Locking Jaw should cover the semi-trailer pin securely.



Figure-8

9- Perform a starting test. Apply the brakes of the semi-trailer and start the truck at low gear; the semi-trailer should not be detached.



### CAUTION

If any of the above conditions are not met, restart the entire locking procedure from the 2nd step. The starting test is not sufficient for secure locking. Visual checks should be performed. If the locking procedure is not completed successfully, a secure connection cannot be made (see Figure 9). The tag on the lock lever should be checked during visual checks.



Figure-9

10- Connect the supply lines and connection cables between the truck and the semi-trailer.

11- Complete the procedure for attaching the semi-trailer as per the instructions of the vehicle manufacturer.



### CAUTION

Attach the cables in such a manner that the pressure air and hydraulic hoses are not tense, they are not bent or rubbing and the canopy can easily follow the trailer in curves, etc. Pay attention to the voltage of the consumers on the semi-trailer before connecting the cable.

5. Wheel (Platform) - Detaching the Semi-Trailer (for 5th wheels of SAF HOLLAND brand)

- 1- Park the vehicle on flat and solid ground.
- 2- Secure and support the semi-trailer as per the instructions of the vehicle manufacturer.
- 3- Disconnect the supply lines and connection cables between the truck and the semi-trailer.
- 4- Unlock the 5th wheel lock with the opening lever. (see Figure 10-11)

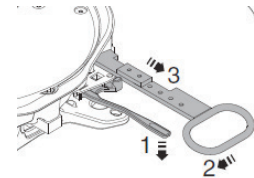

Figure-10

5- Press the safety lever down with your thumb - Arrow 1- and rotate the unlocking handle counter-clockwise - Arrow 2-. Extract the unlocking handle fully - Arrow 3- and attach the part near 5th wheel platform.

At this point, the adjustment plate should not contact 5th wheel platform, there should be a gap between them. (see Figure 10).

# MAINTENANCE AND SERVICE

## Attaching and Detaching a Trailer

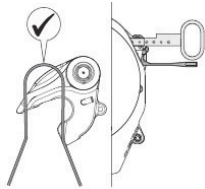

**Figure-11**

6- Make sure that the locking jaw is fully open for attaching/detaching the semi-trailer pin and the locking lever can be slid inside. (see Figure 11)

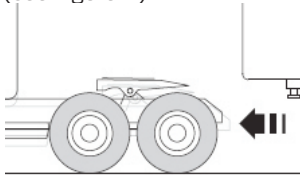

**Figure-12**

7- Drive the truck away from the semi-trailer slowly and straightly. (see Figure 12).  
8- Complete the procedure for detaching the semi-trailer as per the instructions of the vehicle manufacturer.

Note: Once the 5th wheel lock has been unlocked, the locking lever is ready to be slid inside again automatically (the unlocking lever can be slid inside). (see

Figure 13)



**Figure-13**

Note: Figure 13 shows the unlock position for the locking lever. At this point, the adjustment plate is away from 5th wheel body and the safety lever is down. Figure 14 shows the closed position of the lock. At this point, the adjustment plate is contacts 5th wheel body and the safety lever is up.



**Figure-14**



### CAUTION

If there is a damage/flexion on 5th wheel locking lever and the safety lever, visit the workshop and do not attempt to attach a semi-trailer; a secure connection might not be established. Check all parts for wear/corrosion/damage.

### 5. Wheel (Platform) - Trailer Connection (for 5th wheels of JOST brand)

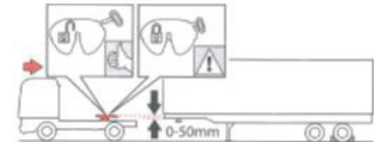

1- Block the wheels of the semi-trailer.

2-Pull the platform lock lever, this shall open the seat for semi-trailer pin.



# MAINTENANCE AND SERVICE

## Attaching and Detaching a Trailer

Drive the vehicle in reverse direction until the semi-trailer king pin fits on the housing on the 5th wheel. Spring release lever will return to its original position.

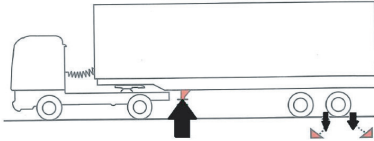

### CAUTION

Attach the cables in such a manner that the pressure air and hydraulic hoses are not tense, they are not bent or rubbing and the canopy can easily follow the trailer in curves, etc. Pay attention to the voltage of the consumers on the canopy/trailer before connecting the cable.

### Detaching the Semi-trailer

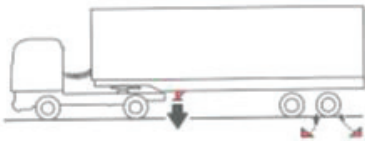

1- Block the wheels .  
Lower the semi-trailer legs to the ground. Disconnect brake and electrical connections.

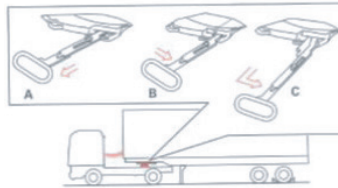

2- Pull the 5th wheel (platform) lock lever.



3- Drive the vehicle so that it will leave the trailer.



### CAUTION

If there is a damage/flexion on 5th wheel locking lever, visit the workshop and do not attempt to attach a semi-trailer; a secure connection might not be established. Check all parts for wear/ corrosion/damage.



### CAUTION

Remove the upper spare tyre bracket before a trailer is fitted to your vehicle.

### Trailer brake

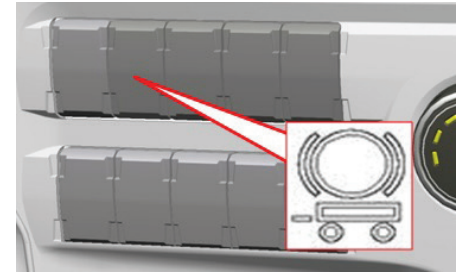

This brakes the semi-trailer only while attaching or detaching the semi-trailer, thus facilitates the attaching and detaching operations. If the  icon on the display is illuminated, this means that there is a fault in the system.

Attaching the Semi-Trailer:

1- Perform the semi-trailer to vehicle air connections.

# MAINTENANCE AND SERVICE

## Attaching and Detaching a Trailer

2- Press and hold the semi-trailer brake button on the center console, semi-trailer brakes shall be applied as long as the button is pressed.

3- Align the 5th wheel (platform) to semi-trailer connection pin and make the connection



### CAUTION

System shall not be activated when the button is pressed below 8 km/h. A Dimmed light on the semi-trailer switch is illuminated continuously is for control purposes. A yellow light shall be illuminated when the switch is pressed.

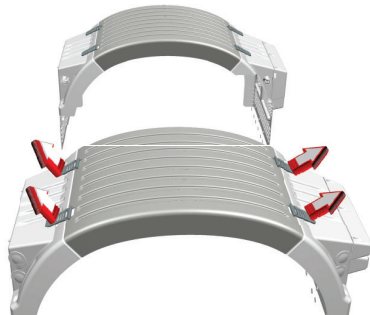

### CAUTION

The upper mudguard can be removed when used below 1100 mm and with trailer.

In case of adding or not subtracting functions to the trailer connectors; check that the gasket which provides leak tightness in trailer connectors is fitted correctly in place.

Ignition shall be turned off when the electrical connection of the trailer is performed.

### Greasing (for 5th wheels of SAF HOLLAND brand)

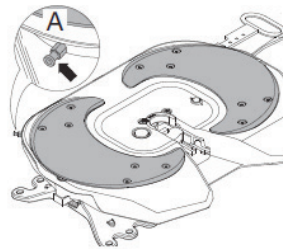

The surface of the platform should be greased with a sufficient quantity of durable, high pressure <NLGI Class 2> grease containing MoS2 or graphite additives prior to the first attachment of a trailer.

Without detaching the semi-trailer, grease through the nipple near the platform regularly at every 10.000 km.

- Clear the used grease on the surface with a scraper before each lubrication.
- However, the greasing periods should be adapted to the relevant operating conditions; shorter or longer intervals are possible.

### Greasing (for 5th wheels of JOST brand)

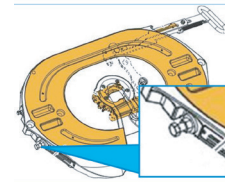

At every 10,000 km:

Apply grease from the grease fitting on the side of the 5th wheel (platform) without detaching the trailer.

Every 50,000 for vehicles used in normal operating conditions.

# MAINTENANCE AND SERVICE

## Attaching and Detaching a Trailer

Every 25,000 for vehicles used in heavy operating conditions;  
Detach the semi-trailer. Remove the grease on 5th wheel (platform) and king pin. Apply grease to the areas shown with yellow color on the illustration.

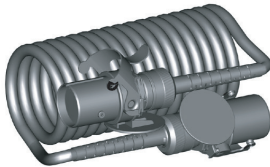

### WARNING

Attach the cables in such a manner that the pressure air and hydraulic hoses are not tense, they are not bent or rubbing and the canopy can easily follow the trailer in curves, etc.

Pay attention to the voltage of the consumers on the canopy/trailer before connecting the cable.

**A 15 – 15 pin connector shall be used in vehicles with ADR.**

Contact Authorized Workshop when you want to install Trailer Axle Lifting function on the vehicle.



### WARNING

Upper part of the live axle fender with 3 parts is advised for operation without trailer.

The upper part shall be removed when the vehicle is operated with trailer and during the removal/installation manoeuvres of the trailer to the vehicle. FORD OTOSAN shall not be held responsible for any damages that occur in the upper part during use with a trailer.



### WARNING

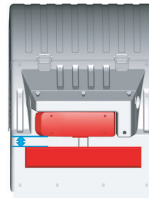

In tractor vehicles, the distance between lower side of the stop lamp on the rear left fender and upper side of the license plate's sheet plate.

### Connection of a Trailer



### CAUTION

If you shall connect a Trailer to your vehicle for the first time, have a brake compatibility test performed to prevent a brake force difference due to the difference of the systems. Otherwise, braking system of the Tractor or trailer may overheat and as a result, the life cycle of the system components may be reduced.



### CAUTION

Always have the brake compatibility test performed at an Authorized brake test center that is capable of taking compatibility graphics.

**Note:** Refer to the Axle Raising Button page on the indicators and controls section of the operation manual for the operation conditions of the axle raising function button.

# MAINTENANCE AND SERVICE

## Fuel Quality and Refuelling

### Fuel Tank

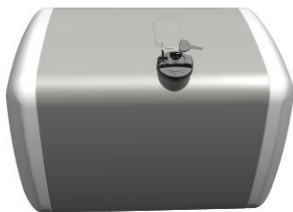

5

Original steel and aluminium fuel tanks approved by Ford Otosan should be used in Ford Trucks vehicles. Using third party fuel tanks other than the tanks designed and test by Ford Otosan may render the warranty void for any fault on the fuel injection system and the vehicle.



### CAUTION

The engine of your vehicle is designed to operate with EURO DIESEL complying with EN590 standards. Thus, usage of cheap diesel fuel causes a high risk for the function of the engine and its components. Use of bad fuel known as cheap fuel oil

reduce the service life and power of our engines. We advise using Euro Diesel (complying with EN 590 standards) to prevent any problem on the fuel system.



### CAUTION

Do not mix petrol in the fuel tank.

### Fuel Tank Flap (lockable)



Ford Fuel tank flap opens counter clockwise in a single action in single-stage. The flap returns to the position where you will lock it in a single action in single-stage when turned clockwise. Cleaning of the fuel tank is essential. Wipe the flap and surroundings without opening the fuel filler flap.



### CAUTION

Paraffin forms in the cold weathers in fuels without any precautions. Paraffin not only clogs the filter elements, but also clogs the fuel pipes. It is very difficult to melt the paraffin once it is formed. Therefore, winter type diesel fuel should be used in the areas where the weather is always cold in winter.



Your vehicle is suitable for using with a fuel with a bio-diesel ratio of 7% (B7).

# MAINTENANCE AND SERVICE

## Exhaust System

### Spark Arrester

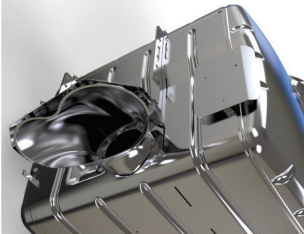

Spark arrester shall be installed at hazardous material loading, unloading locations and fuel stations during fuel filling or draining. When the vehicle is out of the station, the spark arrester shall be removed.

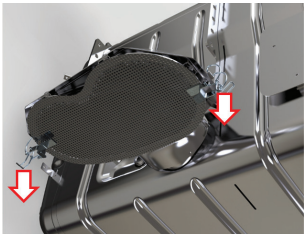

Put on a pair of gloves before installing spark arrester as the muffler is hot. Hook the spark arrester from its clips to the hangers in the muffler. Close the clips and retain the spark arrester to the exhaust.

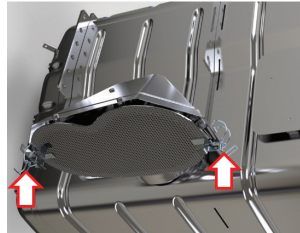

Put on a pair of gloves before removing spark arrester as the muffler and spark arrester is hot. The spark arrester is removed from the exhaust pipe by loosening the brackets on it.



Spark arrester shall be cleaned by water jet to cleanse its pores after every 25 uses.

### CAUTION

#### Washing the exhaust muffler

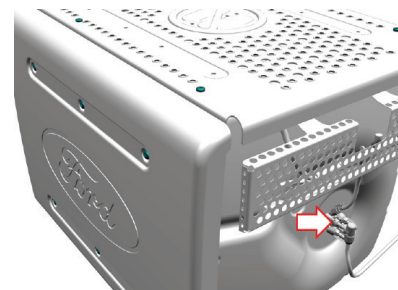

Various sensors and urea injector shall be available on the exhaust muffler. When you wash your vehicle, do not apply water jet on the urea injector on the muffler, sensors and the electric connections. DOC, DPF and SCR catalyst are available in the exhaust muffler. These parts are ceramic-based bricks, and it is definitely not allowed to wash these parts. Do not attempt to wash inside the muffler from the muffler outlet or from the injector housing by removing the urea injector.

# MAINTENANCE AND SERVICE

## Exhaust System

5

### Cleaning of Exhaust Filter

The exhaust filter retains the smut coming from the exhaust gas and decreases the emission values.

With the exhaust filter cleaning operation which can be performed automatically or manually, the smut retained in the filter is burned with regular intervals so that the filter is emptied before filling up and being clogged. In this operation, the exhaust gas is heated by the engine and smut is burned. Driver is informed about the exhaust filter cleaning of the vehicle through the messages displayed on the indicator panel and explained in detail in the following sections



#### WARNING

Since the exhaust gas temperature is high during the exhaust filter cleaning; ensure that the vehicle is not in the same place with flammable (dry grass, leaves), inflammable and explosive materials or in enclosed space. Otherwise, fire risk may occur.



#### WARNING

Ensure that vehicle exhaust cleaning is not performed in locations like hazardous material loading and unloading places or fuelling stations. When necessary, activate the exhaust filter cleaning prevention using exhaust filter cleaning prevention button



#### WARNING

Changes may be observed in engine and exhaust sounds during exhaust filter cleaning.



#### WARNING

During exhaust filter cleaning and right after the cleaning; a metallic smell or crackling sounds may come out of the exhaust side.

### Automatic Cleaning of Exhaust Filter

Exhaust filter cleaning requirement is automatically determined according to the amount of soot accumulated in the filter, the distance the vehicle has travelled, amount of fuel consumed and the engine running hours. In this case, exhaust filter cleaning starts automatically. During the automatic filter cleaning process, the instrument panel shall display green coloured exhaust filter cleaning symbol. When this symbol is displayed, vehicle should be driven normally.



#### WARNING

When you see the Exhaust filter cleaning symbol, you should continue driving normally; there's no need to idle the vehicle and wait.



#### WARNING

Fill rate of the exhaust filter is shown in the graphic available on 'Exhaust Information' screen. By this graphic, for which an example is given below, you may monitor the soot amount in the exhaust filter. When the graphic reaches 100%, your vehicle shall start the exhaust filter cleaning operation automatically, and the soot inside the filter shall be burned.

When the fill rate of exhaust filter exceeds 100%, 9th level of the graphic shall start to flash. You may continue normal operation of your vehicle in this case. Optionally, you may perform a manual exhaust filter cleaning on your vehicle. When the last level of the graphic is filled, final 2 levels of the graphic shall start to flash. In this case, your vehicle is prevented from performing an automatic exhaust filter cleaning to protect the exhaust filter. You shall have a manual exhaust filter cleaning performed as soon as possible. If the graphic does not go below 200% after a manual exhaust filter cleaning operation, you shall take your vehicle to the service.



# MAINTENANCE AND SERVICE

## Exhaust System



Graphic Example



### WARNING

When the exhaust filter reaches a specific fill rate, automatic filter cleaning operation shall start and the soot inside the filter shall be burnt under high temperature. It may be difficult for exhaust gas to reach high temperatures and automatic filter cleaning may be required to be repeated in vehicles that are used with low loads, frequent start and stop operations, operated in idle for long periods and used in short distances (e.g. construction vehicles, mixer series). If your vehicle performs automatic exhaust filter cleaning 2 times (or more) in the same day, it is recommended to perform manual exhaust filter cleaning.

### Manual Cleaning of Exhaust Filter

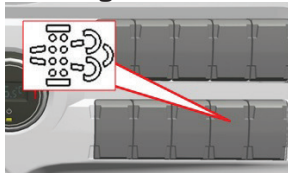

The button on the center console shown above is intended for manual exhaust cleaning. You can perform manual exhaust filter cleaning of the vehicle using this button.



### WARNING

Exhaust gas temperature will be high during manual exhaust filter cleaning, so make sure that the vehicle is not in an enclosed space and the exhaust gases do not come into contact with any flammable, inflammable or explosive material.

Before starting manual exhaust cleaning, please make sure the following conditions are met.

- Vehicle speed shall be "0"
- Parking brake shall be applied
- Gear shall be at neutral
- Accelerator, brake and clutch pedals shall not be pressed
- PTO shall not be active
- Engine coolant temperature shall be above "40" or above
- There shall not be any error codes that prevent exhaust filter cleaning

After you ensure that the conditions above are met:

- Keep the manual exhaust cleaning button pressed for 3 seconds

After this operation, the vehicle checks for suitable conditions for filter cleaning and starts the manual filter cleaning. When exhaust filter cleaning starts, the instrument panel shall display the exhaust filter cleaning symbol and "Exhaust filter

is cleaning" warning for information. If the necessary conditions for exhaust cleaning are not met, "Conditions not suitable for exhaust filter cleaning" warning is displayed. If "conditions not suitable for exhaust filter cleaning" warning is received, the conditions above must be checked again.

When the manual exhaust filter cleaning starts, the engine revolution of the vehicle will increase automatically. The operation shall continue as below:

- Heating 1 - 1200rpm 1 minute (minimum)
- Heating 2 - 1800rpm 2 minutes (minimum)
- Filter cleaning mode - 1800rpm 15 minutes (minimum) - 45 minutes (maximum)
- Cooling mode - 1200rpm 3 minutes (maximum)



### WARNING

You may monitor the time remaining to the end of manual exhaust filter cleaning from the message on the instrument panel. Time remaining to the end of exhaust filter cleaning is shown in minutes.



### WARNING

Exhaust filter cleaning duration may change depending on the amount of smut in the filter and the heating time. Filter cleaning mode can take between 20 minutes minimum and 45 minutes maximum, depending on the amount of smut.

# MAINTENANCE AND SERVICE

## Exhaust System

When the manual exhaust filter cleaning operation is completed, the engine speed will again decrease to idle rpm. If you want to stop the cleaning operation; you can stop the operation by pressing gas, brake or clutch pedal or keeping the exhaust filter cleaning block button pressed for 3 seconds. In that case, vehicle shall decrease to normal idle rpm. Please see the details about Exhaust filter cleaning block button from the relevant chapter.

### **WARNING**

Since exhaust gas temperature shall be high and vehicle speed shall be "0" during manual exhaust filter cleaning, the indicator panel may display "High exhaust gas temperature, please pay attention during parking" information warning. The detailed explanation about this warning can be found in the warnings section.

### Exhaust Filter Cleaning Prevention

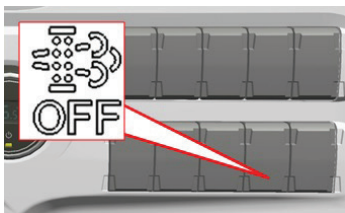

The button on the center console shown below is the exhaust filter cleaning prevention button. You can prevent the exhaust filter cleaning of the vehicle using this button. When exhaust filter cleaning is prevented, the instrument panel shall display "Exhaust filter cleaning is prevented by the driver" warning. The detailed explanation about this warning can be found in the warnings section.

### **WARNING**

If exhaust filter cleaning is prevented by using Exhaust filter cleaning prevention button for a long time, the filter may fill with soot and clog up. When "Please remove exhaust filter cleaning prevention when possible" warning is displayed on the instrument panel, the prevention should be lifted and filter cleaning should be performed as soon as possible. Detailed information about this warning can be read in warnings section.

### **WARNING**

The purpose of exhaust cleaning block button is to prevent the vehicle from cleaning the exhaust whenever the vehicle is near a flammable, inflammable or explosive material.

To activate exhaust filter cleaning prevention,  
➤ Keep the exhaust filter cleaning prevention button pressed for 3 seconds.

When the blocking is activated, instrument panel displays "Exhaust filter cleaning is prevented by the driver" text.

To remove exhaust filter cleaning prevention,  
➤ Keep the exhaust filter cleaning prevention button pressed for 3 seconds. Keep the manual exhaust filter cleaning button pressed for 3 seconds (This will start manual exhaust filter cleaning operation) or,  
➤ Shut off the engine of the vehicle and then restart it

You can confirm that the cleaning prevention is lifted when "Exhaust filter cleaning prevented by the driver" warning is not displayed on the instrument panel.

# MAINTENANCE AND SERVICE

## Urea System



Your Ford Trucks vehicle with Euro6 emission system is equipped with an Urea system.

Urea system is a selective reduction method that removes NOx gases, which are harmful to the environment and human health, from the exhaust gas.

### Selective reduction method

Urea system operates by spraying urea solution to the exhaust gas. Urea solution used in the urea system is defined with DIN 70070 and ISO 22241-1 standards

Your Ford Trucks vehicle with Euro6 emission system is equipped with urea tanks with a capacity of 55L and 75L.



### WARNING

After turning off your vehicle's engine, do not turn off your vehicle's switch within 75 seconds so that the urea remaining in the Urea system can be drawn back into the urea tank. The urea remaining in the system may freeze in cold weather and damage parts of the Urea system. Cases where the switch is turned off before the specified 75sec time period are recorded in the vehicle memory with codes 99-3 and 99-4 under the ECM / ECOTORQ ENGINE modules on the driver screen MAINTENANCE tab.



### WARNING

Urea system is sensitive to contaminants.



Urea indicator

### Important Points:

Urea system is sensitive to dirt, dust and soil. During urea filling, ensure that dirt, dust or contaminants do not go in the urea tank. Ensure to fill urea to your vehicle in a clean environment. Wipe the mud and dirt around the tank cap away before opening the cap. Fill urea fluid directly from its package (can). Make sure the funnel is clean if you will use a funnel. Do not use funnels contaminated with fuel.



If you prefer to filling with a funnel, keep a separate, clean funnel to fill urea available. Do not use funnels contaminated with diesel fuel to fill urea.

# MAINTENANCE AND SERVICE

## Urea System

Do not fill the urea tank with any material other than urea.

Fill the tank with urea complying with DIN 70070 / ISO 22241-1 standard only.

- Do not fill the tank with diesel fuel.
- Do not add water to the tank to increase urea level.

### Quality of the fuel and engine oil used affects Urea system.

#### a-) Sulphur Content in the Fuel

Low quality fuel contains high sulfur ratio. Sulphur may cause blockage of catalyst, a component of the urea system. You should use EuroDiesel only in your vehicle.

#### b-) Engine Oil

Low quality and/or wrong viscosity oil increases the oil vapor in the exhaust. This may cause blockage of the catalyst.

Catalyst is a non-serviceable component that cannot be cleaned.

Exhaust box shall be replaced as a whole when it is blocked. Pay attention to the quality of the urea, fuel and engine oil used and apply all instructions about urea system with care in order to avoid damages with high costs.

If the exhaust temperature is consistently low (buses, delivery trucks), efficiency of Urea system may be reduced and ammonia may come out. Contact your workshop if you continuously smell ammonia.



User shall carry out following precautions to prevent faults and damages in this system. Otherwise any faults occurring should be considered outside of the warranty cover and Ford Otosan will not take any responsibilities!



**You shall comply with the regulations for preventing the accidents!**



### WARNING

Exhaust gas reaches very high temperatures during regeneration or while operating under high load. “HES” light  shall be illuminated on the

warning panel of your vehicle in high exhaust gas temperatures. Switching off your vehicle while this light is illuminated may cause damage to urea system components.

\* Average urea consumption values depend on the test results of the vehicle and the dynamometer. These values may vary for reasons such as vehicle's load condition, environmental factors (ambient temperature, air pressure, relative humidity), engine coolant temperature and urea quality.

# MAINTENANCE AND SERVICE

## Urea System



### WARNING

When improper urea or fuel is used or urea system is rendered inoperable because of contaminants mixed in the urea system, "MIL" lamp shall be illuminated on the instrument cluster and engine power shall be reduced by the engine control unit as the targeted emission values cannot be reached.



### CAUTION

In order to avoid accident risk or problem, it is recommended to refill urea before the urea level falls below a specified critical level.

Engine power shall be reduced %25 by the engine control unit when the urea level is reduced to a level under 3% in your vehicle with Euro 6 emission level. When the urea level is %0, vehicle speed shall be limited with 20km/h by the control unit.

The restrictions that are specified above and applied as a result of running out of urea shall be cancelled when urea is added.

Urea solution complying with DIN70070/ISO22241 standards is used in your vehicle in order to reduce the exhaust emission. As this solution will be reduced in time, you shall check the urea solution level in your vehicle from the urea level indicator on the instrument panel and add urea before it is completely run off. Usage of this solution is legally mandatory; and penalties may apply if you do not comply with this requirement.

Average consumption: 7.2%

# MAINTENANCE AND SERVICE

## Tires and Wheels

### Tire profiles

A minimum profile depth is prescribed for tires by law. Observe the legislation for the relevant country.

For safety reasons, change your tires before reaching the legally advised minimum profile depth.

5



### WARNING

An excessively low tire profile may cause loss of handling at high speeds in case of rain or snow mud conditions. You may lose your handling and cause an accident in these conditions.

### The Condition of the Tires

Check the following conditions regularly every 2 weeks and before a long haul to inspect the condition of the tires:

- External damage
- Cracks and bulges on the tires,
- Foreign material in the tire profile,
- Irregular wear of the profile.



### WARNING

Do not forget that the external damages, bulges and cracks on the tires may cause blowout of the tire. You may cause an accident in these conditions.



### CAUTION

Do not use radial and transversed tires mixed on your vehicle. Use same type of tires on both sides of the same axle. Do not use radial tires on front axles if the rear tires are transversed.

Follow the instructions below strictly:

- Do not attempt to replace the tires if you are not familiar with the required tools, and always follow the instructions.
- Deflate the tires completely before removing the valve.
  - Do not inflate the tires without a protection cage except normal pressure adjustments.
  - Always check the tire pressures with the wheel is cold.

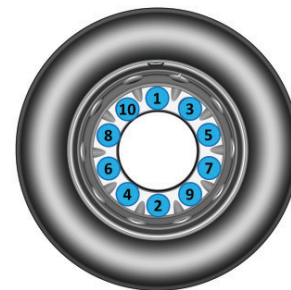

Check the wheel nut torque when you load the vehicle with full load for the first time. (750 Nm +/- 50Nm for front and rear wheels) Tighten the wheel nuts alternately.

### IMPORTANT :

- 1- If the wheel nuts are removed and fitted back for any reason, the wheel nuts shall be checked 50 km after the operation. Tighten to the proper torque value if torque values are not proper
- 2- When a new or newly painted rim is used, tighten the wheel nuts after 1000 to 5000 km of driving.

# MAINTENANCE AND SERVICE

## Tires and Wheels



### CAUTION

Please check the wheel nut torque when you load the vehicle fully for the first time. Check the tire pressure periodically to prevent irregular tire wear.

Do not use radial and transversed tires mixed on your vehicle. Use same type of tires on both sides of the same axle. Do not use radial tires on front axles if the rear tires are transversed. Wrong maintenance on the wheels may be extremely dangerous.

Follow the instructions below strictly:

Do not attempt to replace the tires if you are not familiar with the required tools, and always follow the instructions.

- Deflate the tires completely before removing the valve.
- Do not inflate the tires without a protection cage except normal pressure adjustments.
- Always check the tire pressures with the wheel is cold.

### Tire pressure

Check the pressure of all tires including the spare wheel. All tires should have the specified pressure, and tread depth of the tires should never be under the limit value (6 mm). Also check for damage on the tires. Adjust the pressure of your vehicle's tires by referring to the "Tire pressure" table.

### The Aging of the Tires

- Aging of the tires reduce the operation and traffic safety of the tires. Even unused tires are aged.
- Always replace your tires if they are aged more than 6 years.

### Tire Damages

Tire damages are usually caused by the following reasons:

- Aging of the tire
- Foreign material
- Usage conditions of the vehicle
- Weather conditions
- oil, fuel, grease etc. - Contact with materials
- Dragging on the sidewalks

### Tyre/wheel replacement

Your wheel is specially designed to maximize the appearance performance. Ensure that equipment used for tire replacement do not damage the wheel surface. If it is required to replace the valve during the replacement operation, ensure that alloy wheel valve is issued in Ford Workshops is used

### Wheel maintenance

Clean your wheel frequently. Thus, you may take maximum advantage of appearance performance. Never use brushes, sanders or acidic fluids that may cause scratches on the wheel during cleaning. A damp soft cloth and cleaning agents commonly used for vehicle cleaning is adequate as a special transparent paint is used on the wheel surface.

# MAINTENANCE AND SERVICE

## Tires and Wheels

5



### WARNING

Your wheel is specially polished and covered with a transparent protection layer to protect its brightness. Never re-polish.

This polishing operation would damage the protective layer on the surface. On vehicles with aluminum alloy wheels, wheel nut caps shall be removed with the wheel nut cap pliers delivered with the tools before removing the wheel nuts.



### WARNING

Please, observe the prescribed tire pressure for your vehicle.

Very low tire pressure may cause blowout of the tire at high speeds and loads. You can cause an accident and thus injuries to others due to this.



### CAUTION

Use snow chains only on the outer tyres of your vehicle.

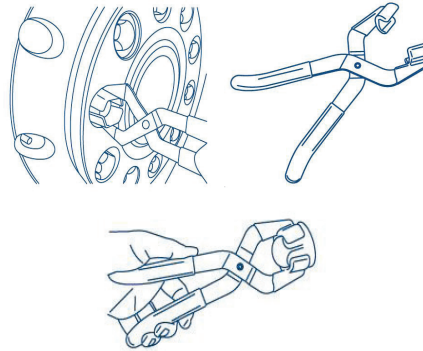

Remove the wheel nut caps with the special pliers provided in the toolbox of the vehicle for aluminum alloyed wheels.

Do not attempt to remove with sharp objects such as screwdrivers etc.

Check the tire pressure periodically to prevent irregular tire wear.

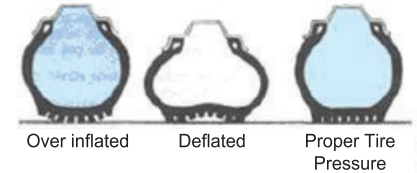

Low pressure cause wear on the shoulder areas of the tire. High pressure cause wear on the back areas of the tire.



# MAINTENANCE AND SERVICE

## Tires and Wheels

### Wheel position replacement

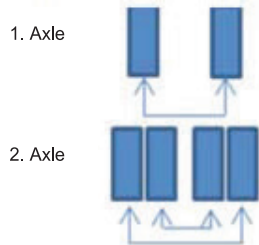

Wheel surfaces of your vehicle are polished specially and coated with protective transparent paint. Use your wheels in their original positions only. Or observe the following replacement chart. A wheel replacement other than the application specified below shall cause appearance problems.

### Fifth wheel position change

If necessary, the position of the fifth wheel can be changed by shifting it a maximum of one hole in the direction of the vehicle cab.

### **CAUTION**

As seen in the table, relocating your tyres at every 40,000 km will enhance the product life of your tyres.

### Wheel Chock

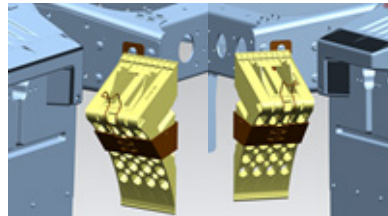

There are 2 wheel chocks, right and left, in the area where the vehicle has rear fenders.

The wheel chock ensures a secure grip of the wheel on different road surfaces. It is simple to use in an easily accessible location.

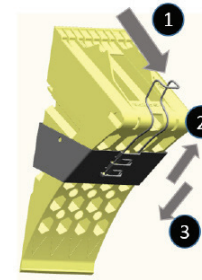

Wheel Chock Removal:

Pull the bracket latch in the direction 1.  
Remove the wheel chock in direction 2.

Wheel Chock Positioning:

Pull the bracket latch in the direction 1.  
Move the wheel chock in the direction 3,  
Make sure that the latch is positioned on the chock.

# MAINTENANCE AND SERVICE

## Tires and Wheels

### POMLEAD WHEEL CARE

#### For preparation;

- Aluminum rim cleaning detergent, microfiber cleaning cloth, dish sponge, waterproof gloves, mask, protective glasses and some water should be available.
- For safety, protective equipment such as waterproof gloves, goggles and masks should be used.
- The vehicle should be brought to the place where the rim cleaning will be done. For better cleaning, the wheels can be removed from the vehicle and the process can be continued.
- Pomlead brand aluminum wheel cleaning detergent or other weak acid content aluminum wheel cleaning and polishing detergents on the market can be used as detergent.

#### The following steps should be followed for maintenance;

1. Remove oil, mud or other dirt from the wheel using water and a damp cloth.
2. Dry the wheel surface after oil, mud and other foreign matter has been removed.
3. Spray the detergent on the rusted or oxidised area and wait 1-3 minutes.  
**Note:** Bubbles may form when the detergent reacts with the stains on the surface.
4. After waiting, surfaces that have been sprayed with detergent should be cleaned by rubbing with a dry microfiber cloth.
5. If there is still a stain, rust or discoloration after cleaning, clean the rusty or stained spots by spraying detergent and rubbing with a dish sponge. If there is a serious discoloration, please repeat the fourth and fifth steps two or three times and the discoloration will be cleared.  
**Note:** Excessive scrubbing with a sponge may cause the surface to become dull.
6. After removing rust and color changes, clean the rim surface with plenty of

water.

7. Finally, dry the rim surface with a dry cloth.

# MAINTENANCE AND SERVICE

## Tires and Wheels

TIRE PRESSURE [Bar]																
Tire Size	Rim	Load Index (Odd / Even)	Tire	6,0	6,25	6,5	6,75	7,0	7,25	7,5	7,75	8,0	8,25	8,5	8,75	9,00
295/60 R22,5	9.00X22,5	150/147	Odd	-	-	-	-	-	-	-	-	-	-	-	-	-
			Even	-	-	9000	-	10000	-	10500	-	11000	-	11600	12000	12300
295/80 R22,5	9.00X22,5	154/148	Odd	-	-	-	-	6000	6200	6400	-	6700	6900	7100	-	-
			Even	-	-	10000	-	10700	11000	11400	11700	12000	12300	12600	-	-
315/60 R22,5	9,00X22,5	154/148	Odd	5420	5600	5780	5955	6130	6305	6480	6650	6825	6990	7160	7330	7500
			Even	-	-	-	10000	10300	10600	10800	-	-	11600	12000	12300	12600
315/70 R22,5	9.00X22,5	156/150	Odd	5780	5975	6165	6355	6540	6725	6910	7095	7280	7460	7640	7820	8000
			Even	9685	10005	10325	10640	10955	11270	11580	11890	12195	12450	12800	13100	13400
315/80 R22,5	9.00X22,5	156/150	Odd	5780	5975	6165	6355	6540	6725	6910	7095	7280	7460	7640	7820	8000
			Even	9685	10005	10325	10640	10955	11270	11580	11890	12195	12450	12800	13100	13400
355/50 R22,5	11.75X22,5	156	Odd	5780	5975	6165	6355	6540	6725	6910	7095	7280	7460	7640	7820	8000
			Even	-	-	-	-	-	-	-	-	-	-	-	-	-
385/55 R22,5	11.75X22,5	160	Odd	6505	-	6935	-	7360	-	7775	-	8190	-	8595	-	9000
			Even	-	-	-	-	-	-	-	-	-	-	-	-	-
385/65 R22,5	11.75X22,5	160	Odd	6505	-	6935	-	7360	-	7775	-	8190	-	8595	-	9000
			Even	-	-	-	-	-	-	-	-	-	-	-	-	-

- Contact your dealership to select the correct size when you replace the tire.
- Always check the tire pressures with the wheel is cold.

# MAINTENANCE AND SERVICE

## Tires and Wheels

5

DIAGNOSTIC CHART	
FAULT	POSSIBLE CAUSE OF THE FAULT
If the vehicle slips to the side when it is braked:	<ul style="list-style-type: none"> <li>• Brake adjustment is faulty</li> <li>• Tires have different pressure values.</li> </ul>
If the vehicle drags to left or right when the steering is released	<ul style="list-style-type: none"> <li>• Incorrect tie-rod adjustment (toe angles)</li> <li>• Irregular wear on the tires</li> <li>• Tires have different pressure values</li> </ul>
If it is difficult to steer the vehicle	<ul style="list-style-type: none"> <li>• Tire is underinflated.</li> <li>• Vehicle is excessively loaded.</li> <li>• Steering system shall be checked.</li> </ul>
If the steering excessive play or looseness	<ul style="list-style-type: none"> <li>• Ball joints are loose</li> <li>• Bushings are worn</li> <li>• Track rod is loose/worn</li> <li>• Steering gears or bearings are worn</li> </ul>
If the outer side of the tire is worn	<ul style="list-style-type: none"> <li>• Excessive toe-out is applied</li> </ul>
If the inner side of the tire is worn	<ul style="list-style-type: none"> <li>• Excessive toe-in is applied</li> </ul>
If the tire is worn on the shoulder areas	<ul style="list-style-type: none"> <li>• Tire pressures are low.</li> </ul>
If the tire is worn on the back areas	<ul style="list-style-type: none"> <li>• Tire pressures are high.</li> </ul>

DIAGNOSTIC CHART	
FAULT	POSSIBLE CAUSE OF THE FAULT
If the tires are worn on both sides	Vehicle is used with excessive load.
	Curves are taken with high speed.
	Vehicle is used with high speed.
	Wheel rotation is not applied.
If a tire is worn more than the other	<ul style="list-style-type: none"> <li>• Pressure value of the worn tire is faulty.</li> <li>• Brake adjustment is faulty</li> <li>• Toe angles are faulty</li> <li>• Shock absorbers are faulty</li> <li>• Wheel rotation is not applied.</li> </ul>
	• Tire pressure is high.
	• Tires are flattened.
	<ul style="list-style-type: none"> <li>• Balancing is faulty</li> <li>• Ball joints are worn</li> </ul>
If the front wheels have excessive vibration	• Tire pressures are high.
	• Tires are flattened.
	• Balancing is faulty.

# MAINTENANCE AND SERVICE

## Tires and Wheels

### Jacking The Vehicle

Jack can be mechanically geared type or hydraulic type. Before lifting the vehicle, park the vehicle on a level ground and apply the park brake. If the vehicle is on a slope and it is to be lifted without applying the parking brake, chock all other wheels. The jack should be placed under the leaf spring as shown in the figure and must be placed on the ground firmly



### CAUTION

If you need to get under a vehicle lifted by a jack, provide additional support under the frame pedestals. There may not be enough space under the front axle while replacing a flat tire. Place the jack under the leaf springs on the closest point to the axle when there is not enough space.

Pay attention not to damage the steering linkages while lifting the vehicle with a jack. Use wooden blocks if required. Check for an obstacle under the vehicle when lowering the vehicle. Do not jack the vehicle from the chassis arms.

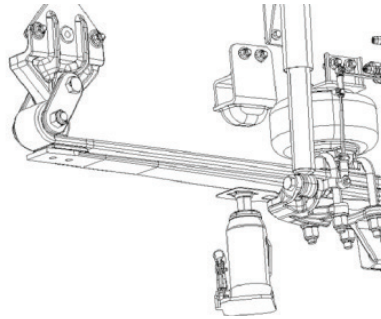

### On vehicles with lowered ride height:

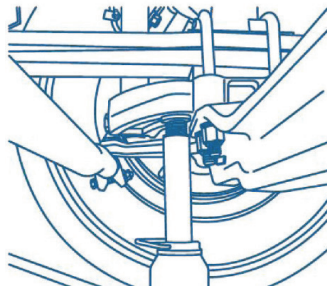

### Spare Wheel and Tire Replacement

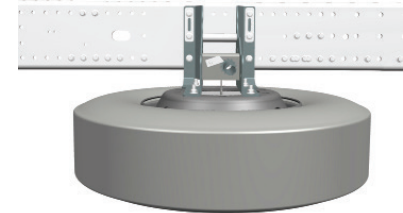

Spare wheel is on the left side of the chassis on vehicles with single fuel tank. To remove the spare wheel from its seat, loosen four bolts connecting it to the holder with the 24 spanner on the toolbox. Spare wheel is hanged with a cable. To release the cable, install the wheel brace to the rotating arm. Turn the brace anticlockwise.

### Installation:

Check the connection cable before installing the spare tire. Cable shall be replaced if it is damaged. Connect the end of the cable to the tire again. Lift the tire with the hexagon wrench and tighten all nuts.

# MAINTENANCE AND SERVICE

## Tires and Wheels

1

### CAUTION

Carefully lower the spare tire. Take necessary precautions to prevent the tire from falling over your foot.

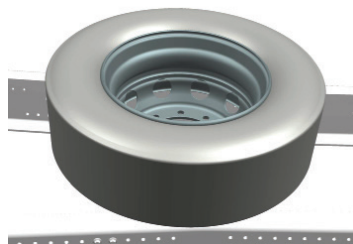

Spare wheel is on the chassis on vehicles with an optional secondary fuel tank. Side skirt shall be removed to take the spare wheel out.

Remove Upper Spare tire bracket before connecting a trailer to your vehicle.

### Side skirt opening mechanism

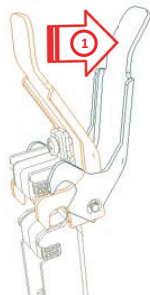

Side skirt panel is released of its locks with the movement of the locks on both front and rear sides to the direction of 1.

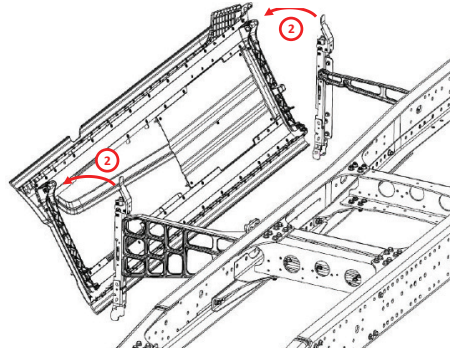

Side skirt panel is moved to the outwards of the vehicle on direction 2 after it is released of its locks.

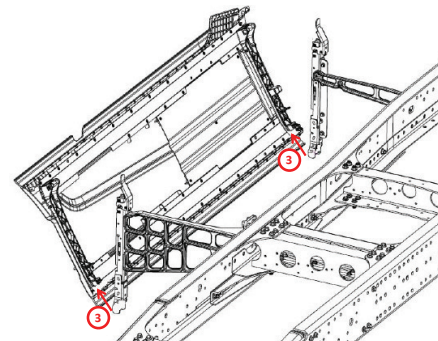

Side skirt panel is moved to the upwards on direction 3 after it is released from the rope hooks on the front and rear sides and it is released from its hinge connections.

# MAINTENANCE AND SERVICE

## Driver Cab

### Tilting The Cab:

If you do not take the necessary precautions and pay necessary attention to the cab lifting procedures, this may cause fatal accidents.

### Before tilting the cab:

- Ensure that no one is standing in front of the vehicle.
- Ensure that adequate space is available in front of the vehicle.

Ensure that no freely moving objects are available in the vehicle. Hard objects may break the windshield when they fall while the cab is being tilted.

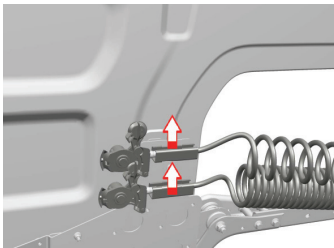

Remove the coupling hoses from their hangers before tilting the cab and do not tilt the cab while the coupling hoses are hanging.



### CAUTION

Do not work under the cab before tilting it completely. This brings a fatal accident risk.



### CAUTION

Do not tilt the cab uphill. As the gradient of the slope acts to move the cab in the closing direction, this may cause risk for the person under the cab. Always tilt the cab on a level surface. If the conditions require that the cab is tilted on a slope, place a safety element between the cab and chassis.



### WARNING

Doors are heavy components; if the doors are opened while the cab is tilted, abrupt opening of the doors may cause serious injuries. If the door should be opened, it shall be opened by supporting from the lower side and slowly.

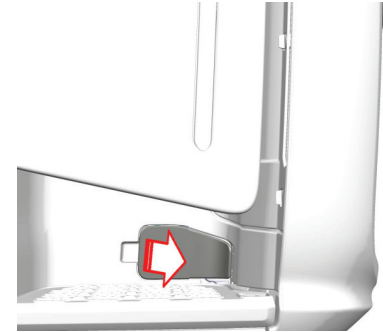

Cab tilt cylinder is located under the cover behind the step on the right side of the vehicle.

Use the brace provided in the toolbox of your vehicle to tilt the cab and then to bring it to the driving position.



### CAUTION

Always open the hood before tilting the cab. Do not open the doors while the cab is tilted.

# MAINTENANCE AND SERVICE

## Driver Cab

5

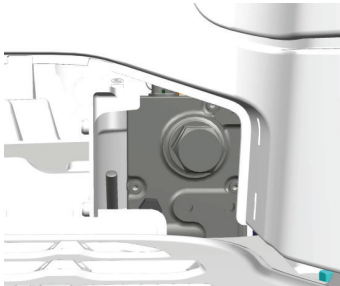

To use the jack, remove the specified cover.

### 1- On vehicles with manually controlled cab tilt cylinder: Tilting the cab:

a) Open the hood of your vehicle.

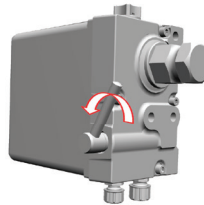

b) Lift the latch on the cab tilt cylinder up.



c) Rotate the hexagonal bolt on the cab tilt cylinder in the direction of arrow until the cab is tilted completely with the wheel nut spanner delivered in the toolbox of your vehicle.

### Returning the cab to driving position:

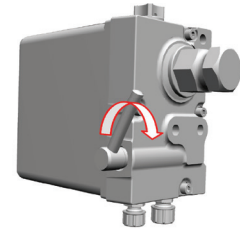

b) Lower the latch on the cab tilt cylinder down



c) Rotate the hexagonal bolt on the cab tilt cylinder with the wheel nut spanner delivered in the toolbox of your vehicle.



# MAINTENANCE AND SERVICE

## Driver Cab

c) If the warning light  is illuminated when you get into your vehicle, then the cab is not correctly locked. Please check.



### CAUTION

Fully open and close the latch on the cab tilt cylinder while you are tilting and bringing the cab back to driving position, respectively. Do not tilt the cab or bring it back to driving position while the latch is in half-open or half-closed position. Otherwise, you may cause faults in the cab tilt cylinder.

### On vehicles with power cab tilt cylinder (optional)

#### Tilting the cab:

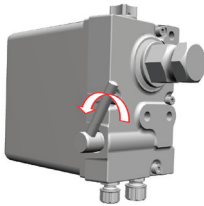

Open the bonnet of your vehicle.

1) Lift the latch on the cab tilt cylinder up.

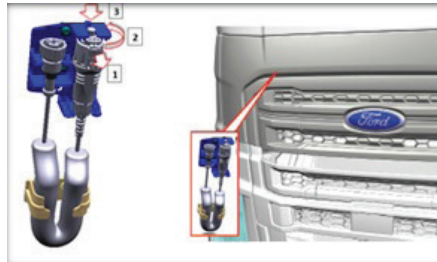

Control Operating Manual (While raising the cab):

- 1-Pull the control out of its housing.
- 2-Open the upper cover automatically by pressing the rocker button on the front face of the control.
- 3-Tilt the cab by pressing the upper button of the control.

Caution: Stand away from the vehicle while lowering and raising the cab

To operate the power cab lifting system, ignition switch shall be at position 1, park brake shall be applied and gear shall be shifted to neutral.

**Returning the cab to driving position:**

1) Lower the latch on the cab tilt cylinder down.

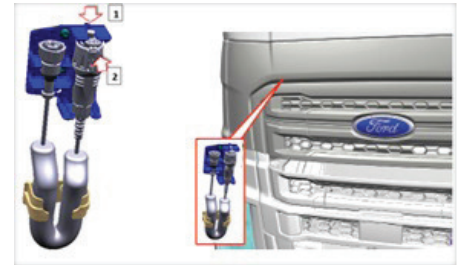

Control Operating Manual (While lowering):

- 1-Lower the cab by pressing the button
  - 2-Upper cover closes automatically while placing the control to its housing.
- Caution: The control has a single placing position, if you cannot place it easily, then you are trying to place it in the wrong direction.

If the  warning is illuminated on the display when you get in the vehicle, this means that cab is not locked correctly. Please check.

# MAINTENANCE AND SERVICE

## Driver Cab

### DIAGNOSTICS

#### On manually controlled tilt cylinders:

##### Cab cannot be tilted

Check the position of latch on the tilt cylinder. It shall be on the tilt direction.

- Tilt cylinder is also serves as the hydraulic oil tank.

Open the cover after cleaning the surroundings of the upper cover. Check with your finger, your finger shall touch the oil.

- Check for oil leaks through the tilt cylinder, hoses, lift hydraulic line.
- Please visit a Ford Trucks authorized dealership if the fault persists.

#### On power cab tilt cylinders:

##### Cab cannot be tilted

- Check the position of latch on the tilt cylinder. It shall be on the tilt direction.
- Check the fuse of the tilt cylinder.
- Check for oil leaks through the tilt cylinder, hoses, lift hydraulic line.
- Please visit a Ford Trucks authorized dealership if the fault persists.

### Air deflector

The air deflector of your vehicle may be adjusted for fuel economy as per different trailer dimensions.

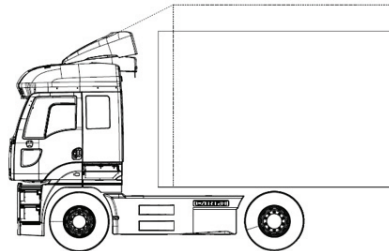
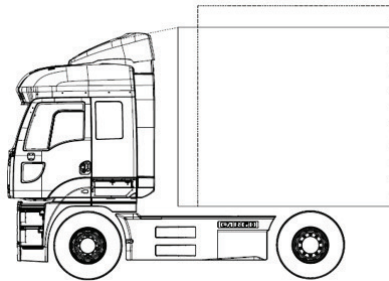

To adjust it, After removing the adjustment bolt (1), it may be pushed and brought back by holding from the handle (2) to the hole with the desired height using the holes on the bracket (shown with an arrow). Installation is complete when adjustment bolt is inserted through the desired hole on the bracket.

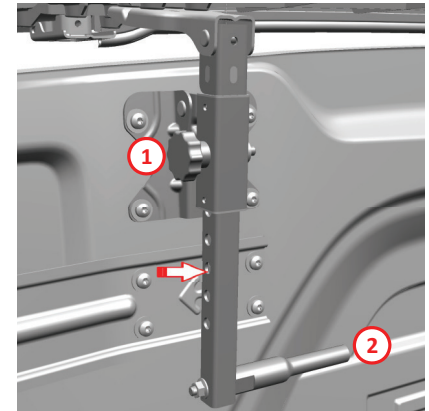

# MAINTENANCE AND SERVICE

## Driver Cab

### Side shroud



Side shroud is opened by holding it from the top and bottom as shown in the figure and then pulling it to the outside (2) of the vehicle and then to the front (2) of the vehicle.



Closing is complete by pulling it backwards only.

# MAINTENANCE AND SERVICE

## Engine

5

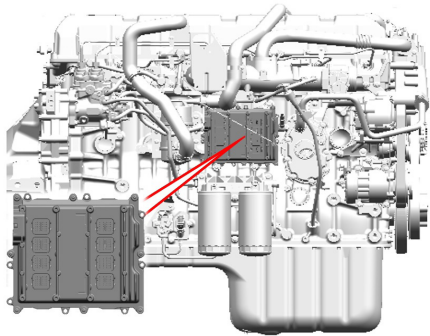

Engine management is provided by the state-of-the-art electronic control unit.



### CAUTION

Remove the plugs of electronic control unit before welding on the vehicle. Otherwise, there is a risk of permanent damage to the electronic control unit. Welding operations shall be performed while the main switch is off.

### Running-in



There is no need to perform a special application in the running-in period of the engine. Drive the vehicle with the proper gear so that tachometer remains in the green zone as always.

### Daily Inspections

- Check the coolant level. If the level is at minimum or less, add 50% distilled water and 50% antifreeze (WSS M97B44 D) mixture.
- Check windshield washer liquid level, add clean water if the level is dropped.
- Check for any oil or liquid leaks in general.
- Check the operation of the service and park brakes.
- Drain the water and oil collected in the air tanks completely by pulling the drain ring.

# MAINTENANCE AND SERVICE

## Engine

### Weekly Inspections:

- Check the engine oil level.
- Check the tire pressures (while the wheel is cold), tread depth and damage condition on the tires.
- Check the clutch hydraulic fluid level, add hydraulic fluid if the level is dropped.
- Check the wear on the brake lining wear by looking through the lining inspection hole.
- Lubricate the semi-trailer connection platform.

### Monthly Inspections

- Check the power steering fluid level.

### Engine Oil Level Inspection

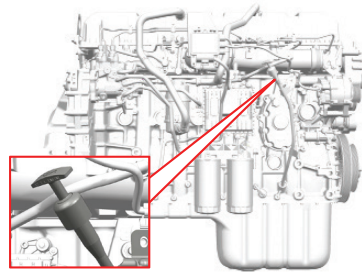

Engine oil level shall be inspected weekly. Engine oil dipstick is placed on the right side of the vehicle.

- Park the vehicle on a level ground. Switch off the ignition, apply the parking brake, and take the necessary precautions.
- Wait for 10 minutes to allow flowing of the oil to the oil pan.
- Tilt the cab.
- Take the dipstick out.
- Wipe with a lint-free clean cloth, install the dipstick again and secure it.

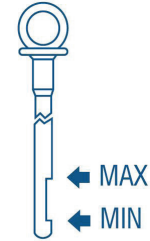

- The oil level must be between the MIN and MAX lines. The difference between “MIN” and “MAX” on the dipstick is 15 liters.



### CAUTION

Use oil with the specifications approved by Ford Otosan only for your engine. Using improper oil for your engine may cause serious and costly faults.

# MAINTENANCE AND SERVICE

## Engine

5

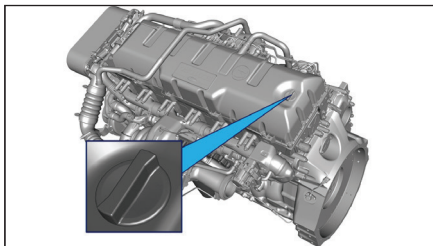

Add oil if the level is less than MIN, engine oil filler cap is on the cylinder head cover. Wipe the surroundings of the cap before opening it. Pay attention to cleanliness if you would use equipment such as measuring container, funnel etc.

### Fuel consumption value:

Oil consumption amount of the engine between 2 maintenances depends directly on the operating conditions of the vehicle (loaded-unloaded, short-long haul, fuel quality, engine oil quality). Under normal operating conditions, engine oil consumption up to 0.8 lt / 1,000 km between 2 maintenance operations is acceptable. These consumption values may vary under heavy operating conditions.

### Adding Fluid

When the engine oil level is reduced to critical level, red “Engine oil low”

 warning shall be displayed on the instrument.

In this case, engine oil shall be brought to required level by adding engine oil within 500 km maximum. We advise you to have the engine oil adding operations performed in Ford Trucks authorized dealerships.



### CAUTION

Do not replace engine filters and tamper with its connections when the ignition switch is at position 2. Important Points:  
1- When the warning light illuminates, lacking amount of oil in the engine is about 15 liters. Oil shall be add until the level observed on the dipstick reaches a level between MIN and MAX marks. Add oil gradually and in a controlled manner. Run the engine for a few minutes after each oil adding operation. Stop the engine, wait for 10 minutes, and check the engine oil level with oil dipstick.  
2- Do not add oil more than required.

Excessive engine oil may cause faults such as deterioration of seals, excessive heating, blocking of catalyst, oil leaks from various

points on the engine.

3- Engine oils may lose their specifications if engine oils with different specifications and different brands are mixed.

In order to prevent costly damages to your engine out of warranty cover, we recommend you to top up the oil in your engine with oils with the same brands and specifications when adding oil is required between 2 maintenance operations.



### CAUTION

When the engine oil level is reduced to the minimum level, “engine oil level warning light” is illuminated on the display. 

In this case:

- 1- It is possible to drive up to the first rest stop. Road assistance is not required.
- 2- Vehicle shall be parked on a level ground on the rest stop area, park brake shall be applied and required safety precautions shall be taken.
- 3- When the vehicle has rested for 75 minutes with ignition off, oil shall completely flow to the oil pan.
- 4- Without turning the ignition / engine on, cab shall be tilted and oil level shall be measured with the engine oil dipstick.

# MAINTENANCE AND SERVICE

## Engine

### After the measurement:

**If engine oil level is not blow the MIN level,** drive the vehicle for a little more to allow the engine control unit to take new measurements and perform an evaluation. In order to evaluate new measurements, the vehicle shall be driven at a speed over 20km/h, usually between 550-1800rpm for 30 to 60 minutes. If the oil warning is still burning after this time, it will be enough to direct the car to the authorized service as soon as possible. Road assistance is not required.

**If engine oil level is under MIN level,** you shall add engine oil with the specifications recommended with the required amount. Drive the vehicle for a little more to allow the engine control unit to take new measurements and perform an evaluation. In order to evaluate new measurements, the vehicle shall be driven at a speed over 20km/h, usually between 550-1800rpm for 30 to 60 minutes. The oil level warning lamp shall be turned off after this period. Road assistance is not required for this application, too.



### CAUTION

Excessive oil is harmful for your engine. This may cause overheating of the engine, damage to the seals and oil leaks from several points of the engine. It may also cause blockage of the exhaust catalyst pores.

We recommend you have your vehicle maintained at Ford Services by professionals.

Engine oil pressure and oil level is checked by the sensors, and the driver is informed with a warning light in case of an abnormal condition.



### Low Engine Oil Pressure

Stop the engine. Contact a Ford Cargo Authorized Dealership.



### Low engine oil level

Tilt the cab, and check the engine oil level with oil dipstick.



### Oil maintenance interval reached

Take your vehicle to a Ford Cargo Authorized Dealership as soon as possible for oil maintenance.



### Engine coolant temperature

#### warning

This informs the driver about overheating of the engine. Stop the vehicle immediately and run the engine at idle for a few minutes.

Check for coolant leaks. Stop the engine if the coolant temperature does not drop. Check the water pump drive belt, fan and shroud, and the coolant level. Contact an authorized dealer.

# MAINTENANCE AND SERVICE

## Engine



### Engine and drivetrain system malfunction

This indicates a malfunction in the engine and/or drivetrain components. Vehicle may continue normal operation or engine may reduce the power based on the severity of the fault.

Please visit the nearest Ford Trucks authorized dealership.



### MIL (malfunction indicator lamp)

Before starting the engine: Engine malfunction lamp of your vehicle will self check by illuminating for 5 seconds when the ignition switch is on (before engine start).

This is the lamp check phase.

The lamp will be dim out for 10 seconds after that.

Then it will be illuminating again for 5 seconds. This is the preparation phase.

If all data is ready for examination the lamp will stay illuminated for 5 seconds, if not, it will blink 5 times in 5 seconds. (This does not affect the function, and is not a sign of malfunction.)

Before going to the next phase, lamp will dim out for 5 seconds.

If a malfunction is detected, lamp will show one of the 4 following behaviours till the engine start:

- Lamp shall light up continuously. **In this case it is recommended that you drive to an authorized workshop.**

- It shall light up for 3 seconds and dim out for 5 seconds.

**It is recommended to you to drive to an authorized workshop in this case.**

- Lamp shall light up 2 times in 3 seconds, and dim out for 5 seconds. **It is recommended to you to drive to an authorized workshop in this case.**

- If there are no errors, it shall light up for 1 second and dim out for 5 seconds.

### After starting the engine:

If there is an error, lamp will light up in 2 ways according to the error type,

- Lamp shall light up continuously. **In this case**

**it is recommended that you drive to an authorized workshop.**

- Lamp shall light up for 15 seconds, and dim out completely. **It is recommended to you to drive to an authorized workshop in this case.**

- If there is no error, lamp shall not light up.

### Cleaning the engine:

Do not apply pressurized water to the sensors and electronic control unit while you are washing the outer surface of the engine with pressurized water. Water ingress to electronic units will cause short circuits on the electrical pins, thus malfunctions on the engine.



### CAUTION

Check the engine oil level before starting on your journey. Engine oil level is not displayed while driving.



# MAINTENANCE AND SERVICE

## Engine

### On-chassis fuel filter (Fuel pre-filter)

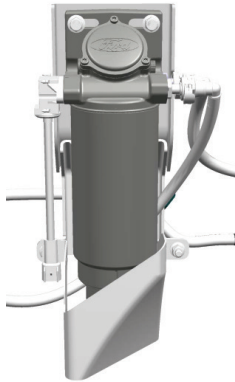

Fuel pre-filter performs the initial filtration of the fuel drawn from the fuel tank. Also, it separates the water inside the fuel and provides fuel separated from water to the engine. Filtered water is collected in the container under the filter assembly.



If the “water in fuel” warning light illuminates when the ignition is on, loosen or unclip the integrated water sensor under the filter assembly and close it when clean fuel appears.

Tighten the water sensor securely when you are closing the tap. Otherwise, air may enter the engine, and this may cause fuel leak.



### WARNING

Care that is shown for the cleaning of the fuel filters will contribute the service life of main fuel filter on engine and fuel system of the engine.

Fuel does not flow to the engine and system takes air when the vehicle runs out of fuel or when the low quality fuel is frozen in the filter. After performing the necessary corrective action, bleeding air from the system is performed by the hand pump. Press until hand pump is stiffened, and start the engine when the pump is stiffened.

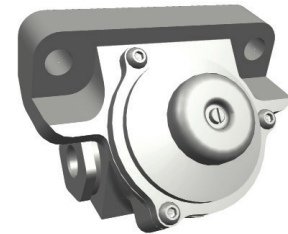

### WARNING

Do not continue on starting attempts if the vehicle does not start in a few attempt. There may still be air inside the fuel line. Pump fuel with the hand pump, then restart again.

# MAINTENANCE AND SERVICE

## Engine

### CAUTION

Fuel that will be taken for the vehicles operating in cold climates shall be cold climate fuel resistant to waxing in cold weather. Otherwise, water inside the fuel will freeze and prevent flow of fuel to the engine; and the engine will not start.

### CAUTION

Antifreeze does not prevent freezing of the engine in winter only. It also lubricates the water pump and extends its service life. Ensure that the antifreeze complies with the Ford specifications when you are purchasing antifreeze. Lime and other chemicals in the non-distilled water cause corrosion in the cast engine block.

### CAUTION

The cover of the coolant reservoir shall always be tightly closed. Engine coolant reservoir is under the hood. The coolant level shall be between the MIN and the MAX marks when the engine is cold, and it shall be inspected daily.

If the coolant level is lower than the MIN mark, the warning light shall illuminate on the display. In this case:

- Stop the engine considering the road safety.
- Check the coolant level in the coolant reservoir under the hood.
- If the level is lower than the MIN mark, add 50% distilled water and 50% antifreeze until the level reaches between MIN and MAX marks.

In the case of a malfunction in the low temperature circuit, a malfunction in the electrical pump or a water leak; the vehicle will start cutting down the torque.

5

### Engine coolant



Engine coolant contains 50% antifreeze and 50% distilled water. Coolant circulates inside the engine block and cools the engine components. This fluid also cools the retarder oil in vehicles with retarder.

### CAUTION

Freezing temperature of the 50% distilled water and 50% antifreeze mixture is  $-37^{\circ}\text{C}$ . On colder climates, it is possible to achieve protection up to  $-50^{\circ}\text{C}$  by adjusting the mixture ratio to 40% distilled water and 60% antifreeze. Maximum antifreeze ratio is 60%, never exceed this ratio.

# MAINTENANCE AND SERVICE

## Engine

You may find more information on the maintenances and contact information for the Ford Trucks authorized dealerships in the Warranty Manual.

Distance and engine operating hours to the maintenance are displayed on the displays of your vehicle.

We advise you to have the periodical maintenance and repair operations on your vehicle performed in Ford Trucks authorized dealerships.

### CAUTION

#### **Risk of Serious Injury**

Coolant is pressurized and VERY HOT. Do not open the cover immediately. Wait at least half an hour and open the cover with a thick cloth or protective gloves, if available. Open the cover slowly first to discharge the pressure in the reservoir; then open the cover completely.

- Check under the vehicle for any coolant leaks.
- Tilt the cab, check the belts for any broken or excessively loosened belt. If the fan cable breaks, fan rotates in maximum rpm; since this will worsen the fuel economy, it is advised you to go to service after the warning light goes on.

### CAUTION

Do not refill with water when the cooling system of a hot engine is empty or its coolant is missing. Add hot water if available, or wait until the engine is cooled.

**Replacement interval of the air filters depend on the operating conditions of the vehicle.**

Air filter shall be replaced in an authorized dealership when x light is illuminated. The air filter clogged warning will be illuminated on the digital display when the air filter element is clogged. Contact a Ford Otosan Authorized Dealership for the replacement of the air filter elements after this warning is illuminated.



### WARNING

Always tilt the cab completely to replace air filters. Tilting the cab halfway may cause personal injuries. Ensure that the air filter cover is installed so that the dust draining hole faces downward.

### WARNING

Do not operate the vehicle with air filters removed. As the air drawn to the turbocharger and thus the engine shall not be filtered, this may cause serious and expensive malfunctions on components such as turbocharger and engine.

# MAINTENANCE AND SERVICE

## Engine

### Cleaning of water separation valves on the air intake system

There are 3 valves for separation of water and dust in the air intake system of your vehicle. It is important that these valves are maintained once per month to ensure their correct operation. These maintenance operations shall be performed as follows:

5

Air outlet valve (1) is shaped like a plug. Without removing the valve, ensure that the dust and mud is cleaned by scraping the edges of the plug slightly.

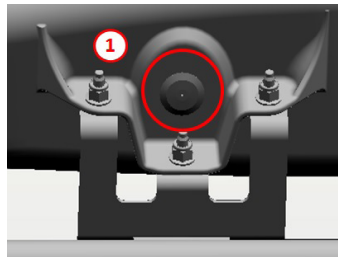

Press on the air filter valve (1) and filter inlet pipe valve (3) from their external surfaces and ensure that the dust and mud inside the valves is drained. Normal position of the valves is the closed position. Do not leave the valves at continuously open position.

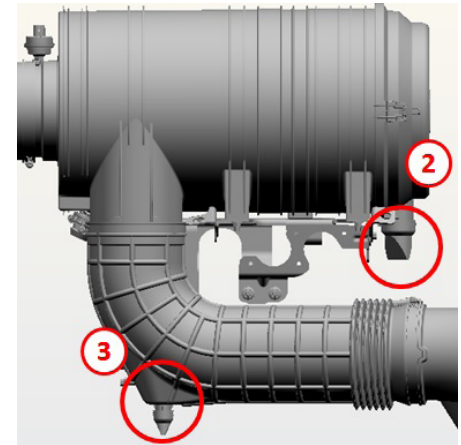

# MAINTENANCE AND SERVICE

## Engine

### Inspection and Cleaning of the Flyscreen



Flyscreen, placed in front of the radiator, is a component that resembles a curtain and it can be cleaned.

Its purpose is to prevent objects such as flies, dust, bugs etc. from entering directly to the radiator. Inspect the flyscreen as per the working conditions and clean it if it is dirty. Cleaning is performed by removing the flyscreen from the radiator and applying pressurized water or air to the flyscreen.

#### Removal of the flyscreen:

Pull the spring connections of flyscreen lower bar downwards and take it out of it seats that it is connected to. Then, by removing the butterfly bolts used in the upper and side joints, all the connections of the flyscreen are removed. The flyscreen is pulled up from the radiator

cavity and removed from the vehicle.



#### CAUTION

Dirty flyscreen prevents air flow to the intercooler, thus to the radiator, and reduces the cooling capacity of the engine. Therefore, the cleaning procedure described above is important.

#### Engine Start Stop buttons

##### Conditions for Starting the Engine

- The ignition shall be at position '2'.
- The cab shall be overturned
- Doors must be closed
- Parking brake must be applied
- Vehicle speed must be "0".



#### WARNING

**Note:**In an event where one of these conditions are not met, the engine will not be engaged with Start Button.



1-Start

2-Stop

#### You can do the following with Two Buttons:

- Engine Starting
- Engine speed increase
- Engine speed reduction
- Motor shutdown

#### The System Operation Principle is specified below:

The Function consists of 4 basic conditions;

1-When the ignition is in position 2, by pressing the Start button, the engine is engaged.

2-When the engine is engaged, the first long pressing the Start button will increase the engine torque.

When the button is released, the engine torque is stabilized at the level.

3- First long press after increasing the engine speed reduces the speed, and it is kept constant at the point where the button is released

4-Stop button is only used to halt the engine that is engaged.

In any event, when Stop button is pressed the engine halts.

# MAINTENANCE AND SERVICE

## Engine

5

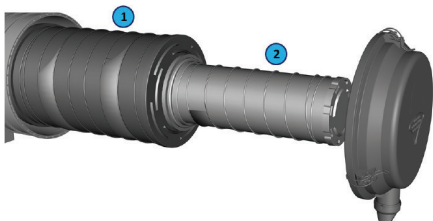

Air filter is composed of 2 components:  
1- outer filter  
2- inner safety element



### WARNING

**Note:** Never expose the air filters to compressed air. Compressed air distorts the paper structure of the air filter elements and it may even tear them.

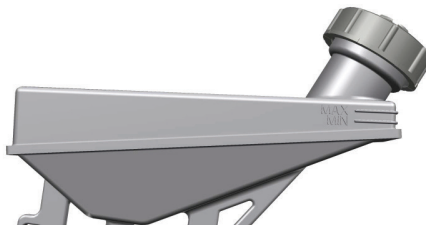

Clutch fluid reservoir is placed under the front hood. The level of fluid shall be up to the level mark on the reservoir.

Add fluid with proper specifications given if the level is low and close the cover tightly.



### WARNING

Clutch fluid damages painted surfaces. Take necessary precautions to prevent spilling over the painted surfaces while adding fluid.



### WARNING

The cover of the clutch fluid reservoir shall always be tightly closed. Ingress of foreign material such as water or dirt causes damage to the fuel system. Ingress of air to the system may also cause malfunctions.



# MAINTENANCE AND SERVICE

## Steering Wheel

### Steering Fluid

Steering fluid reservoir is located under the cab on the right side of the vehicle.

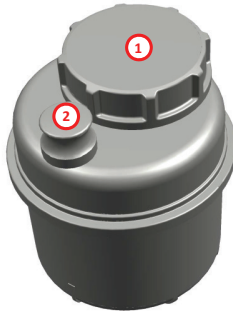

- 1-Cover
- 2- Oil dipstick

### Fluid level check:

- 1- Tilt the cab
- 2- Wipe the dipstick with a clean cloth and open its clip.

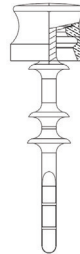

- 3- Take the dipstick out, wipe with a clean cloth, install the dipstick securely and take it out again.

- 4- The oil level must be between the lines shown in the figure.

Add fluid if the fluid level is low. Steering system is very sensitive to foreign material such as dust, dirt etc. Pay maximum attention to cleanliness while checking the fluid level and/or adding fluid. Prevent dirt ingress to the system.

### Adding Fluid

- 1- Wipe the reservoir cover and surroundings with a cloth
- 2- Open the reservoir cover and add required amount of fluid.
- 3- Close the reservoir cover tightly.



### WARNING

Steering gear upper area Steering column joint connection area shall be cleaned with non-pressurized water or a brush. The mentioned area shall be protected if it is cleaned with pressurized water.

# MAINTENANCE AND SERVICE

## Towing the Vehicle

Towing of the vehicle requires specialist knowledge that is not explained in this manual. Make sure that the vehicle is towed by specialist staff.



Draw pin installation location on your vehicle is on the front grille panel. Draw pin is designed for installation to the right-hand side only as standard. Draw pin system that may be installed to both sides may be procured as optional if requested at the time of ordering for the vehicle.

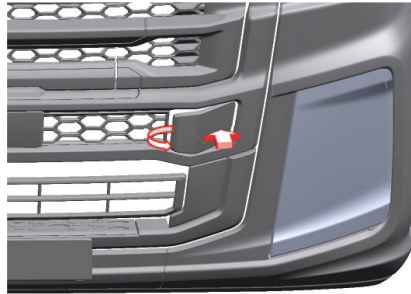

Press the draw pin cover from the side shown with an arrow. Cover shall rotate and open. Place it on its seat on the vehicle and press on it to install the part.

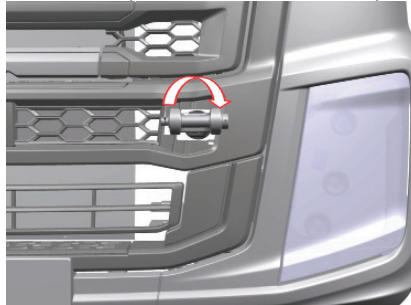

Install draw pin by rotating it clockwise as shown in the figure.

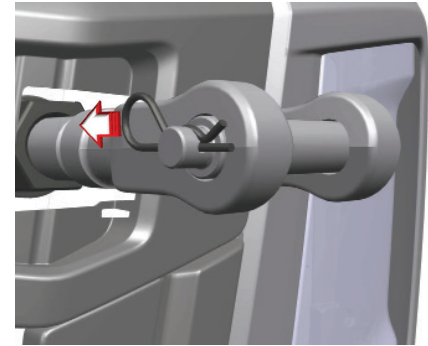

Remove the draw pin and attach the towing cable.

In order to tow the vehicle, the drive shaft shall be removed from the axle side and secured to the chassis.

If the vehicle should be transported on a trailer with a deep platform, the specified 4m height may be exceeded. Consider the maximum passing heights of the underpasses. You may cause an accident.



# MAINTENANCE AND SERVICE

## Towing the Vehicle



### WARNING

Do not tow the vehicle crosswise.

### Risk of Accident

If the vehicle is towed with the engine is not running, the steering assist and air supplies will not be operating.

As this would require more steering effort, you may get out of the road or bump the towing vehicle in curves.

You may install an emergency steering pump.

If you agree on special signs with the driver of the towing vehicle before towing the vehicle, it will prevent occurring of these kind of problems.



### CAUTION

In order to tow the vehicle, the drive shaft connected to the live axle must be removed. For multi-piece drive shafts, it will only be sufficient to remove the rearmost drive shaft.

### While towing your vehicle



### CAUTION

- The drive shaft needs to be removed first before towing your vehicle. If the drive shaft is not removed, the movement shall be transmitted from the wheels to the transmission and operate the internal components of the transmission that is not pumping oil. In such a case, you may experience serious transmission malfunctions. This is considered out of warranty cover.



### CAUTION

- Have your vehicle towed by specialists only. Improper towing may cause damage to your vehicle and you may experience serious accidents.

### Procedures to be Performed:

- If your engine is operating, have your vehicle towed as your engine is operated. If it is not possible to operate your engine, brake air pressure may be reduced after a while and this locks the emergency brakes. This may cause serious accidents and damages. To prevent this condition, discharge the emergency brakes before towing your vehicle or connect an air line to the air tubes of your vehicle if the specifications of the towing vehicle allows this.
- The drive shaft needs to be removed first before towing your vehicle.
- The key should be on the ignition switch and on position (1) as your vehicle has a steering lock.
- The vehicle should only be towed with a drawbar. Towing with soft, breakable materials cause a serious risk of accident.  
Do not exceed the speed limit specified by traffic law.

# MAINTENANCE AND SERVICE

## Electrical Systems

### Batteries

#### WARNINGS



#### **Danger of explosion**

Explosive gases form when the batteries are charged. Charge the batteries in well ventilated places only.



#### **Danger of explosion**

Avoid sparks!  
Do not work with open fires or lights near batteries. Do not smoke.



#### **Battery acid may cause burns.**

Use acid-resistant protective gloves!  
Neutralize the skin or cloth that the battery acid is spilt on with soapy water or a neutralizing material and rinse with water.



#### **Wear protective goggles.**

Electrolyte may be spilt on the eyes while mixing it with water. Wash your eyes with plenty of water and seek medical help immediately.



#### **Keep away from children**

Children cannot decide the risks involved with batteries and acid.



Observe the safety warnings, protection precautions and manners described in this manual when you are dealing with the battery.

#### DAMAGES TO THE ENVIRONMENT



Batteries contain hazardous material. Do not dispose with household waste.



Dispose the batteries without harming the environment. Return the batteries to a FORD OTOSAN authorized dealership or a collecting facility for waste batteries.

Transport and store the batteries filled with electrolyte in upwards condition. Secure the batteries against turning over when you are carrying them. Battery acid may contaminate the environment by vaporizing from the air discharge holes.

# MAINTENANCE AND SERVICE

## Electrical Systems

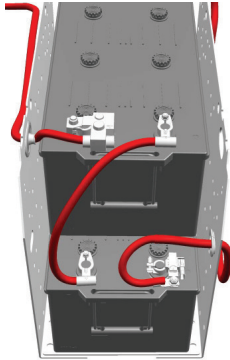

Batteries should always be charged as required in order to have a long service life. We advise you to use the circuit breaker next to the battery tray to preserve the service life of the battery when the vehicle is not going to be used for a long time. Check the battery voltage level if the vehicle is parked for a long period of time. 12.2 V voltage level measured in a battery indicates that battery charge level is too low. In this case, best method is to leave the vehicle running in the shortest possible time in order to charge the batteries.

### Disconnecting the battery terminals

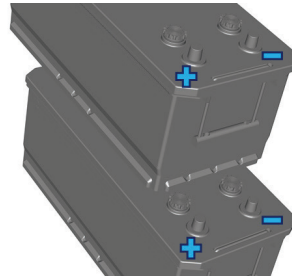

Disconnect the terminals after 5 minutes minimum when you stop the engine. This is needed to supply power to the Urea system that will operate after a while when the engine is stopped. Otherwise, your Urea system (or vehicle) may be damaged.

- Remove the key from the ignition switch.
- Turn off all consumers.
- Open the battery housing cover and remove it.
- Disconnect the negative terminals.
- Disconnect the positive terminals.



### WARNING

Risk of short circuit occurs when the positive terminal of the battery connected contacts the components of the vehicle. Thus, the gas mixture that may easily explode may ignite. You and other persons may get injured in such a condition. Do not place metal objects or tools on the battery.

Disconnect the negative terminal first, and then the positive terminal while disconnecting the terminals.

Connect the positive terminal first, and the negative terminal then while connecting the terminals.

Do not loosen or disconnect the terminals when the engine is running.

BATTERIES REQUIRE MAINTENANCE

# MAINTENANCE AND SERVICE

## Electrical Systems

### Connecting the battery terminals

#### **CAUTION**

Remove the key from the ignition switch.  
Turn off all consumers.  
Connect the positive terminals. Do not confuse terminals!

- Connect the negative terminals.
- Fit the battery cover.
- Perform the following when the power is disconnected (e.g. when the terminals are disconnected and connected again).
- Set the clock.

### Removing the battery cover

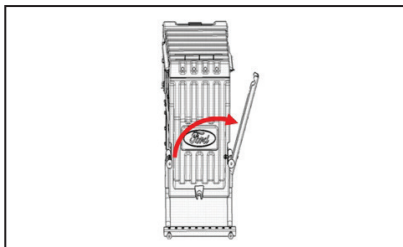

Open the upper connection profile of the step bracket under the battery cover in the direction of the arrow.

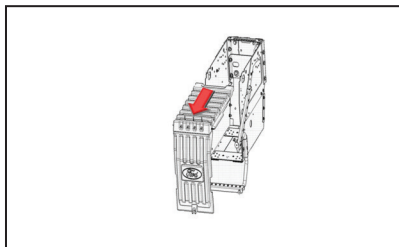

Then pull the battery cover to yourself in the arrow direction and remove easily.

After the battery replacement; if the replacement is made outside authorized service and parameter update is not performed, "replacement notification" signal is sent for 10 seconds. In this case, the hazard lights button must be pressed 8 times within 14 seconds while the ignition is on.

Flashing of the battery condition indicator indicates that the battery charge level is very low. In this case, best method is to leave the vehicle running in the shortest possible time in order to charge the batteries.

### Checking the electrolyte level

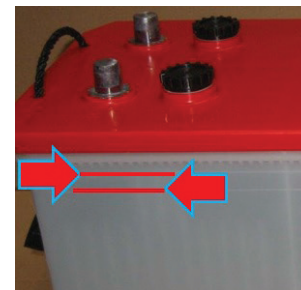

#### **CAUTION**

Battery box is coloured white to allow that the fluid can be seen from the outside. Refer to the min/max. signs to understand if the fluid level is adequate. Check the battery acid concentration level every six months or 40.000 km.

Tap water decreases battery power. Only add demineralized or distilled water. Do not use a metal hone when you are filling the batteries. There is a risk of short circuit.

# MAINTENANCE AND SERVICE

## Electrical Systems

- Open the battery housing cover and remove it.
- Remove the plugs.
- Check the battery acid concentration level and correct if required.
- Install the plugs.
- Fit the battery cover.



### WARNING

Batteries are very heavy. You may drop the battery and injure yourself or others when you are removing or installing a battery. Thus, be careful when you are removing the battery and use the help of a second technician.



### WARNING

Make sure that the battery housing cover is closed. Ensure that the battery surface is always clean.



### WARNING

There is a risk of explosion because of the forming of explosive gases. Avoid sparks! Do not work with open fires or lights near batteries. Do not smoke.



Flashing of the battery condition indicator indicates that the battery charge level is very low. In this case, best method is to leave the vehicle running in the shortest possible time in order to charge the batteries.

### Using Jumper Cables

When your battery is discharged, you may take starting aid from another vehicle. If your battery is discharged and you want to start your engine with jumper cables, read the following instructions carefully to prevent damage to the charge system.

Provide starting aid from

- Two 12 V batteries connected in series
- Vehicles with 24 V power system only.

- Keep the spare batteries in a well-ventilated environment.
- Turn off all other consumers.

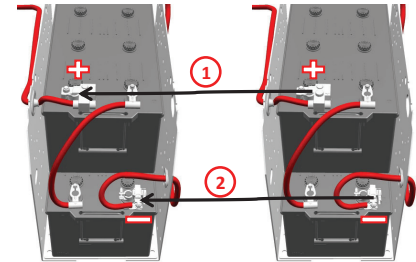

- Connect the positive (+) terminal of the spare battery to the positive terminal of the vehicle battery, and negative (-) terminal of the spare battery to the negative terminal of the vehicle battery.
- Connect the positive terminals of the batteries first, and then the negative terminals using starting aid cables.
- Start the engine. Run the engine under 1000 rpm.

# MAINTENANCE AND SERVICE

## Electrical Systems

5

- Disconnect the negative jumper cable from the spare battery first, and then the vehicle battery. Disconnect the positive cable in the same way.
- If two vehicles are used, make sure that their bodies or frames do not contact each other.
- Do not approach the batteries with sparks or naked flames as the hydrogen will always be available.
- Connect the jumper cables as specified above to prevent sparks in the vicinity of the batteries.

- Always use booster cables with insulated clamps and adequate size cable. Do not disconnect the battery from the vehicle's electrical system.

### **To start the engine:**

a- Run the engine of the vehicle with charged battery with a high speed.

b- Start the engine of the vehicle with the flat battery.

c-Run both vehicles for a minimum of three minutes before disconnecting the

Otherwise, you may damage electronic equipment like the engine electronic control unit or the digital instrument cluster.

# MAINTENANCE AND SERVICE

## Electrical Systems

Fuse and Relay Table

R25		R20		R15		R10		R5		F12	F6
R27	R24	R22	R19	R17	R14	R12	R9	R7	R4	R2	
R26	R23	R21	R18	R16	R13	R11	R8	R6	R3	R1	
F102	F93	F84	F75	F66	F57	F48	F39	F30	F21	F11	F5
F101	F92	F83	F74	F65	F56	F47	F38	F29	F20	F10	F4
F100	F91	F82	F73	F64	F55	F46	F37	F28	F19	F9	F3
F99	F90	F81	F72	F63	F54	F45	F36	F27	F18	F8	F2
F98	F89	F80	F71	F62	F53	F44	F35	F26	F17	F7	F1
F97	F88	F79	F70	F61	F52	F43	F34	F25	F16		
F96	F87	F78	F69	F60	F51	F42	F33	F24	F15		
F95	F86	F77	F68	F59	F50	F41	F32	F23	F14		
F94	F85	F76	F67	F58	F49	F40	F31	F22	F13		

# MAINTENANCE AND SERVICE

## Electrical Systems

5

NO	VALUE	SYSTEM
FS001	30 A	AUTOMATIC TRANSMISSION CONTROL UNIT - 1
FS002	40 A	WINDSHIELD HEATING - 1
FS003	40 A	WINDSHIELD HEATING - 2
FS004	40 A	PARK AIR CONDITIONER
FS006	20 A	12V POWER OUTLET
FS007	30 A	AIR CONDITIONER FAN
FS009	50 A	CAB LIFTING MOTOR
FS010	30 A	24V KL30 FOR FS101
FS011	40 A	24V POWER OUTLET PANEL AND BED
FS013	20 A	ENGINE CONTROL UNIT
FS014	25 A	AUTOMATIC TRANSMISSION CONTROL UNIT - 2
FS015	7.5 A	RETARDER
FS016	15 A	PARKING LAMPS
FS017	5 A	TACHOGRAPH
FS018	3 A	FRONT CAMERA
FS019	7.5 A	DOOR LOCK BUTTON
FS020	20 A	BODY CONTROL UNIT - 1

NO	VALUE	SYSTEM
FS021	5 A	ELECTRONIC AIR PRESSURE UNIT
FS022	20 A	BODY CONTROL UNIT - 2
FS023	10 A	BRAKE LAMPS
FS024	7.5 A	REFRIGERATOR
FS025	20 A	BODY CONTROL UNIT - 3
FS026	20 A	NOX SENSORS 1 & 2 & UREA QUALITY AND LEVEL SENSOR
FS027	20 A	WET TYPE HEATER
FS028	10 A	MIRROR HEATERS
FS029	15 A	TRIPLE DOME PARKING LAMPS & DOME BEACON
FS030	10 A	DRY TYPE HEATER
FS031	30 A	7 PIN TRAILER CONNECTOR
FS032	3 A	ERA GLONASS EMERGENCY CALL UNIT
FS033	20 A	BODY CONTROL UNIT - 4
FS034	20 A	BODY CONTROL UNIT - 5
FS035	20 A	BODY CONTROL UNIT - 6

\*On vehicles with an Ecotorq transmission



# MAINTENANCE AND SERVICE

## Electrical Systems

5

NO	VALUE	SYSTEM
FS036	20 A	BODY CONTROL UNIT - 7
FS037	3 A	RIGHT AND LEFT ARM
FS038	10 A	OBD (ON BOARD DIAGNOSIS SYSTEM) CONNECTORS 1 & 2
FS039	20 A	BODY CONTROL UNIT - 8
FS040	7.5 A	SHADE MOTOR
FS041	25 A	CONVERTOR 2
FS042	5 A	MAP ASSISTED SPEED CONTROL UNIT
FS043	15 A	HORN
FS044	15 A	EBS UNIT
FS045	3 A	BUTTONS
FS046	25 A	CONVERTOR 2
FS047	15 A	DENOX CONTROL UNIT AND UREA HEATERS
FS048	20 A	AFTER SALES CHASSIS AND DOME CONNECTORS
FS050	20 A	24V POWER OUTLET - PANEL
FS051	5 A	AIR HORN KEY

NO	VALUE	SYSTEM
FS052	20 A	AFTER SALES CAB CONNECTOR & FLEET MONITORING UNIT
FS053	15 A	LIGHTER
FS054	5 A	TIRE PRESSURE DISPLAY UNIT / TOLL COLLECT
FS055	5 A	IGNITION SWITCH
FS056	10 A	INSTRUMENT PANEL
FS057	3 A	TRAILER AXLE LIFTING
FS058	3 A	ENGINE RPM
FS059	10 A	15-PIN TRAILER CONNECTOR & AFTER SALES CHASSIS AND DOME CONNECTORS - PARK
FS060	5 A	VEHICLE PARK LAMPS
FS061	1 A	SUNROOF WINDOW (HEADLINING CONSOLE SIDE) BUTTON - WAKING
FS062	1 A	SUNROOF WINDOW (BED SIDE) BUTTON - WAKING
FS063	1 A	BED LAMP BUTTON - WAKING
FS064	3 A	"TACHOGRAPH (FOR VEHICLES CARRYING DANGEROUS GOODS)"
FS066	5 A	"INTERIOR CABINET LAMPS & DOOR LOCKING BUTTONS"
FS067	7.5 A	EBS UNIT - IGNITION

# MAINTENANCE AND SERVICE

## Electrical Systems

5

NO	VALUE	SYSTEM
FS068	3 A	INSTRUMENT PANEL - IGNITION
FS069	3 A	ELECTRONIC AIR PRESSURE UNIT - IGNITION
FS070	7.5 A	RETARDER - IGNITION
FS071	5 A	TACHOGRAPH - IGNITION
FS072	3 A	LANE DEPARTURE WARNING SYSTEM BUZZER
FS073	7.5 A	RADAR & CAMERA & MAP ASSISTED SPEED CONTROL UNIT - IGNITION
FS074	7.5 A	AUTOMATIC TRANSMISSION CONTROL UNIT - IGNITION
FS075	5 A	ENGINE CONTROL UNIT - IGNITION
FS076	3 A	ELECTRONICALLY AIR SUSPENSION CONTROL
FS077	10 A	SEAT HEATER
FS078	10A	PASSENGER SEAT HEATER
FS079	3 A	BRAKE LAMPS
FS080	15 A	AFTER SALES CHASSIS AND DOME CONNECTORS & FLEET MONITORING UNIT - IGNITION
FS081	3 A	ERA GLONASS EMERGENCY CALL UNIT - IGNITION
FS082	7.5 A	WORKING LAMP - IGNITION
FS083	3 A	RIGHT AND LEFT ARM - IGNITION
FS084	5 A	BUTTONS & STEERING LOCK VALVE - IGNITION

NO	VALUE	SYSTEM
FS085	10 A	REVERSING LAMPS
FS087	20 A	FUEL HEATER
FS088	7.5 A	7-PIN TRAILER CONNECTOR - IGNITION
FS089	3 A	CONVERTORS 1 & 2 - IGNITION
FS090	10 A	NOX SENSORS 1 & 2
FS091	7.5 A	UREA QUALITY AND LEVEL SENSOR
FS092	15 A	TURBO & EXHAUST GAS RECIRCULATION
FS093	7.5 A	Front headlamp leveling motor & Rain sensor & IN-VEHICLE TEMPERATURE AND HUMIDITY SENSOR
FS094	5 A	WINDOW AND MIRROR BUTTON
FS097	20 A	BODY CONTROL UNIT - 12V SUPPLY
FS098	7.5 A	A/C CONTROL UNIT
FS099	7.5 A	EXTERIOR CABINET LAMPS
FS100	3 A	HEADLAMP SWITCH
FS101	7.5 A	HORN AND A/C MOTOR RELAY COIL (+)
FS102	20 A	RADIO

# MAINTENANCE AND SERVICE

## Electrical Systems

5

NO	VALUE	SYSTEM
R01	24V 40A	IGNITION/START - 1
R02	24V 40A	IGNITION/START - 2
R03	12V 20A	POWER OUTLETS (SEALED RELAY)
R04	24V 20A	LIGHTING WORKING LAMP
R05	24V 40A	IGNITION/ACCESSORY
R06	24V 20A	SHADE MOTOR - UP
R07	24V 20A	ENGINE OFF
R08	24V 20A	HORN
R09	24V 20A	UREA MODULE AND UREA HEATERS
R10	24V 40A	A/C MOTOR
R11	24V 20A	REVERSE LAMPS & REVERSE WARNING
R12	24V 20A	UREA QUALITY AND LEVEL SENSOR & NOX SENSORS & TURBO & EXHAUST GAS RECIRCULATION
R13	24V 20A	TRAILER AXLE LIFTING

NO	VALUE	SYSTEM
R14	24V 20A	AFTER-SALE RIGHT TURN SIGNAL
R15	24V 40A	CAB LIFTING MOTOR
R16	24V 20A	AFTER-SALE AIR HORN
R17	24V 20A	BRAKE LAMPS
R18		EMPTY
R19	24V 20A	PARKING LAMPS
R20	24V 40A	WINDSHIELD HEATING - 1
R21	24V 20A	TRIPLE DOME PARK LAMPS
R22		EMPTY
R23	24V 20A	DOME BEACON
R24	24V 20A	MIRROR HEATERS
R25	24V 40A	WINDSHIELD HEATING - 2
R26	24V 20A	DOOR LOCKING BUTTONS
R27	24V 20A	SHADE MOTOR - DOWN

**Fuse and Relay Table (On Engine)**

F1	F2	F3
----	----	----

NO	VALUE	SYSTEM
F1		EMPTY
F2	150 A	MEGA FUSE - ALTERNATOR
F3	175 A	MEGA FUSE - GRILLED HEATER

# MAINTENANCE AND SERVICE

## Electrical Systems

### Trailer installation kits

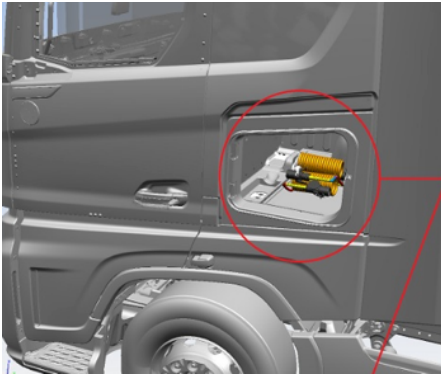

5

Trailer installation kits located in the trunk of your vehicle should be kept in the trunk or inserted into the parking sockets when not in use.

### Diode directions

FUSE BOX FRONT VIEW

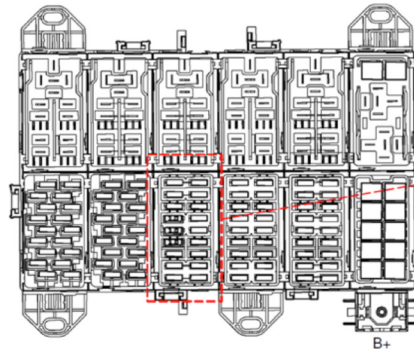

CARTRIDGE 4



The diodes shall be fitted into the slots in clockwise order with a value of 1.0 shown on them.

# MAINTENANCE AND SERVICE

## Changing Bulbs

### Removing the headlamp rear cover



Open the door, rotate the removable locks on the part in the direction of the arrow.

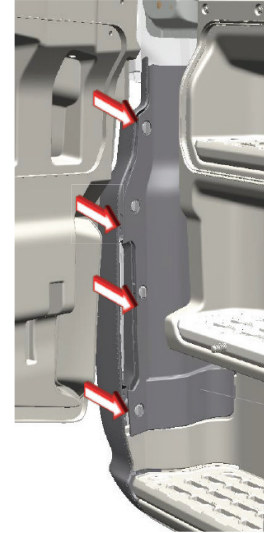
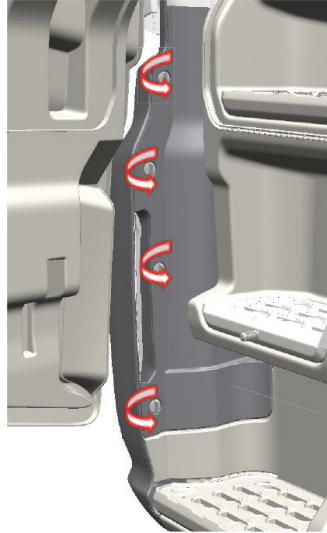

Pull backwards from the section of the part that are indicated with arrows.

# MAINTENANCE AND SERVICE

## Changing Bulbs

5

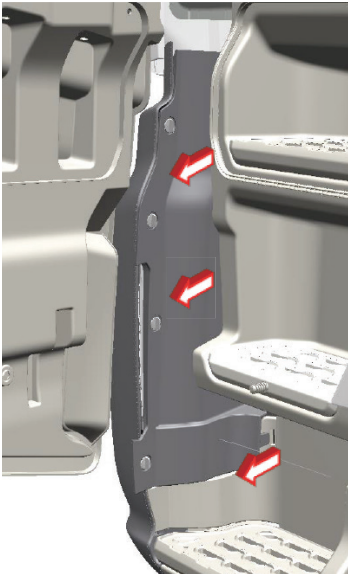

Release the part from its seat on the bottom and remove it.

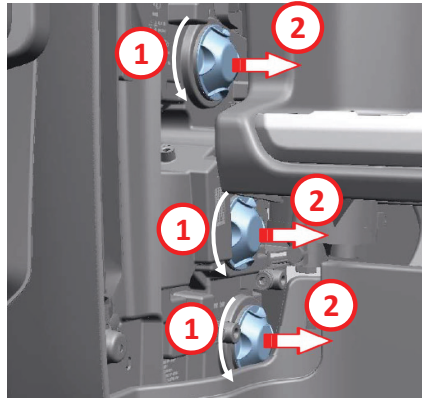

Remove the cover by rotating it counter-clockwise and unlocking it for the main beam on the top, dipped beam in the center and fog lamp at the bottom.

### Bulb types to be used:

Main Beam: H1 24V 70W  
Dipped Beam: H7 24V 70W  
Fog Lamp: H11 24V 70W



### CAUTION

Do not touch the bulbs with your hands when you are replacing the halogen bulbs, otherwise the bulbs will never work again.

# MAINTENANCE AND SERVICE

## Changing Bulbs

### High beam

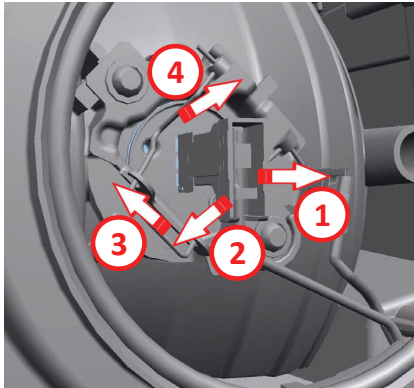

Remove the connector behind the bulb by pulling it out first to replace the main beam bulb. Then, press on the retaining spring wire and release and open it from tabs by sliding to the upper left side and remove the bulb. Insert the spring to the tabs and install the bulb connector after placing the new bulb.

### Headlamp dipped beam

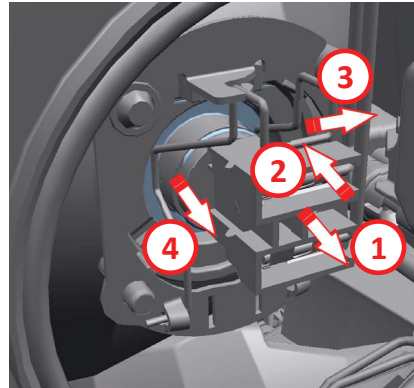

Remove the connector behind the bulb by pulling it out first to replace the dipped beam bulb. Then, press on the retaining spring wire and release and open it from the by sliding to the right-hand side and remove the bulb. Insert the spring to the tab and install the bulb connector after placing the new bulb.

### Fog lamp

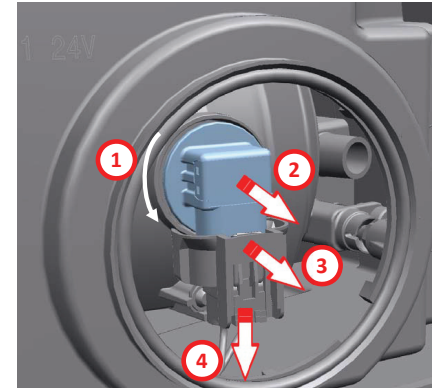









Remove the bulb by rotating it counter-clockwise and unlocking it to replace the fog lamp bulb. Then, release the bulb by pulling the connector tab out. Place the new bulb to its seat after installing it to the connector and lock by rotating clockwise.

# MAINTENANCE AND SERVICE

## Locations of the Tools in the Vehicle

5

PARTS	PART NAME	LOCATION
	JACK	ON THE TOOLBOX BEHIND THE PASSENGER SEAT
	TOOLBOX	ON THE TOOLBOX BEHIND THE PASSENGER SEAT
	WHEEL NUT WRENCH	ON THE TOOLBOX BEHIND THE PASSENGER SEAT
	LEVER	UNDER THE HOOD

PARTS	PART NAME	LOCATION
	TRAILER CONNECTION WIRE	ON THE TOOLBOX BEHIND THE DRIVER'S SEAT
	TIRE INFLATION HOSE	ON THE TOOLBOX BEHIND THE PASSENGER SEAT
	TOW HOOK	ON THE TOOLBOX BEHIND THE PASSENGER SEAT
	WARNINGLAMP	IN GLOVE BOX



# MAINTENANCE AND SERVICE

## Questions and Remedies

FAULT	CAUSE AND REMEDY
<b>ENGINE IS STALLING</b>	Transfer pump does not intake, check the front filter. Check main fuel filter. The hole on the fuel tank cover may be clogged. Open it. There is water in the fuel. Replace if necessary. There is air in the fuel injection system. Check the fuel pipes and hoses. Freezing or air ingress in the fuel settling bottle filter or fuel intake lines; check and clean if required.
<b>ENGINE IS RUNNING ROUGHLY</b>	There may be air or clogging in the fuel pipes. Bleed air. Incorrect valve adjustment Intake manifold or air filter may be clogged. Clean or replace. There is water in the fuel. Replace if necessary. There may be clogging or damage in the exhaust pipes or the muffler. Have them inspected. Injector pump intake may be insufficient. Contact an authorized dealer.
<b>ENGINE IS DIFFICULT TO START</b>	Air filter may be contaminated. Clean or replace. Starter is faulty. Have it repaired. Battery discharged. Have it charged. Exhaust system may be clogged. Have them inspected. Front heater is faulty. Have them inspected. Fuel level low. Top up. There may be air in the fuel system. Bleed air .

# MAINTENANCE AND SERVICE

## Questions and Remedies

5

FAULT	CAUSE AND REMEDY
<b>ENGINE IS OVERHEATING</b>	Coolant level is low. Top up. An object may be blocking the front of the radiator. Please check. Radiator cores may be dirty. Clean the radiator. Water pump belt adjustment is faulty Have them inspected. Exhaust system may be clogged, have it inspected. Thermostat is faulty. Check it (and replace it, if necessary). Water pump is faulty. Have it inspected by an authorized dealership.
<b>LOW TRACTION</b>	Engine compression level is low. Have them inspected. Air filter may be contaminated. Clean or replace. Incorrect valve adjustment Contact an authorized dealer.
<b>BLACKSMOKE FROM THE EXHAUST</b>	Air filter may be contaminated. Clean or replace. Intake manifold or exhaust system may be clogged. Have them inspected. Compression may be too low. Cylinder head gasket leaks. Incorrect valve adjustment or valves faulty Engine worn. Drive to an authorized dealer and have the necessary inspections performed. Turbo unit is faulty Drive to an authorized dealer. Air leak on the Intercooler and / or hose connections. Inspect the hose and clamps. Breakage of the diesel particulate filter (Euro-6 vehicles)

# MAINTENANCE AND SERVICE

## Questions and Remedies

FAULT	CAUSE AND REMEDY
<b>LOW OIL PRESSURE</b>	Oil pressure indicator is clogged or faulty Have them inspected. Oil filter element is clogged. Replace. Oil strainer may be clogged Clean it. Oil pump is faulty. Check the tread clearance, and the operation of drive shaft and safety valve.
<b>POWER STEERING</b>  <b>POWERSTEERING NOISE ON THE STEERING WHEEL</b>	Hydraulic fluid levels are low, refill and bleed the air.  Contact authorized service for a general inspection of the system.
<b>STEERING WHEEL IS ROTATING ROUGHLY</b>	Check tyre pressures Vehicle may be overloaded. Check the suitability for load capacity. Please visit the nearest authorized service if load limits are not exceeded.
<b>CLEARANCE ON THE STEERING WHEEL</b>	Check for looseness on the steering system. Also, have the setting checked in the authorized dealership. Have the front alignment adjustment of your vehicle checked, and have the tire pressures inspected.
<b>ENGINE DOES NOT SUPPLY POWER</b>	Engine is faulty. Contact an authorized dealership to have the fault repaired. Exhaust or intake manifold is loose Contact an authorized dealer. Wrapping on turbine shaft bearings. It should be repaired. Turbo pressure may be lower than necessary. You are recommended to contact nearest FORD OTOSAN authorized dealership.

# TECHNICAL SPECIFICATIONS

6

# TECHNICAL SPECIFICATIONS

## Labels

### Vehicle Identification Plate

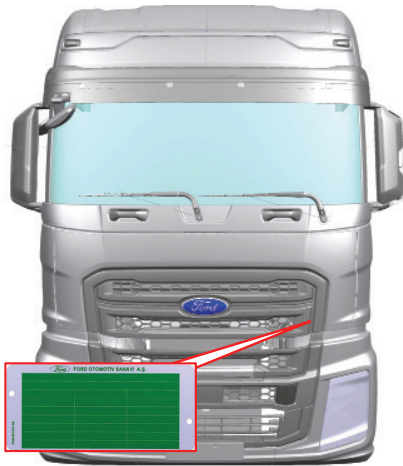

Vehicle identification plate is located under the hood in the front of the cab.

### Over the right chassis arm of the vehicle:

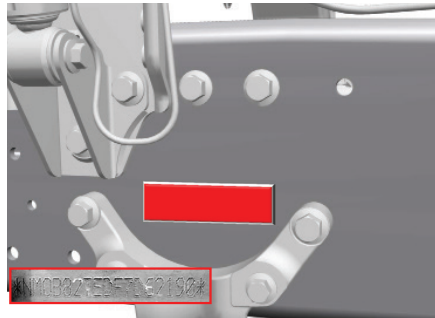

Chassis number is located under the front bonnet and on the chassis right hand-side arm and on the right chassis lower flange beside the engine crossmember; it consists of 17 digits. Example: NMOK13TEDFBL12345

### Engine label

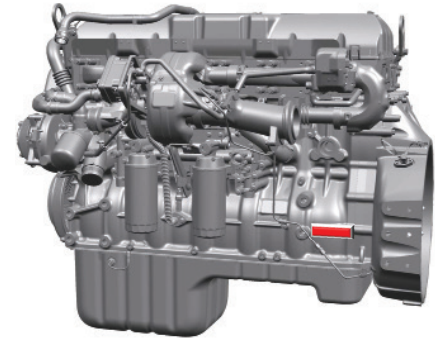

Metal label with the engine type and serial number inscribed on it is placed on the lower right side of the turbocharger intake pipe.

# TECHNICAL SPECIFICATIONS

## Fluid Filling Capacities

6

PART	DESCRIPTION	CAPACITY		SAE NO.	FORD SPEC. NO.	SPEC. NO.
ENGINE OIL	12.7 L EU6	46 L		5W20	WSS-M2C219-A1	
	12.7 L EU5	40 L		10W40	WSS-M2C944-A (Cold Climate: WSS-M2C212-A1)	
TRANSMISSION OIL		After an oil change	For initial fill after repair			
	ZF 12 TX 2620 w INT	19 L	23.5 L			Fully Syn. (TE-MLO2E ZF)
	ZF 12 TX 2620 w/o INT	12 L	13.5 L			Fully Syn. (TE-MLO2E ZF)
	16 S 2600 AMT DD	12 L	13 L			
The reference values may change during the oil change.						
DIFFERENTIAL OIL	FOAXLE XSS-510	18.5 L		85W140		J2360
	FOAXLE XSS-470	12.5 L		75W85		J2360
STEERING FLUID	SINGLE STEER	4.5 L			WSS-M2C938-A	
ENGINE COOLANT / ANTIFREEZE*	12.7 L w INT	69 L			WSS-M97B44-D	
	12.7 L w/o INT	50 L			WSS-M97B44-D	
The reference values represent initial amount of oil. Total amount of coolant decrease in the event of an coolant change						
CAB LIFT OIL	ALL FMAX VEHICLES	0.58 L			SLM-6C9100-A	

# TECHNICAL SPECIFICATIONS

## Fluid Filling Capacities

PART	DESCRIPTON	CAPACITY	SAE NO.	FORD SPEC. NO.	SPEC. NO.
<b>HUB GREASE</b>	DISC BRAKE VEHICLES	650 G/WH		WSS-M1C275-A	
	DRIVE AXLE (ONLY 510 TYPE)	900 G/WH		WSD-M1C228-A	
<b>GREASE</b>	5th WHEEL CABLE	**	Lithium	WSD-M1C228-A	
	KINGPIN	15 G/PIN	Lithium	WSD-M1C228-A	
	SPRING FRICTION PAD	**	Lithium	WSD-M1C228-A	
	REAR LEAF SPRING FRONT EYE BUSHING	**	Lithium	WSD-M1C228-A	
	BATTERY TERMINAL	20 G	Vaseline		ESE N99B144B
	BRAKE SHOES	**	Copper Additive		
	CAB LATCH BUSHING	0.024 G		WSD-M1C228-A	
	DOOR TENSIONER	75 G/DOOR	Poly Urea NLGI 2	WSD-M1C228-A	
	DOOR LOCKS & LATCH	**	Lithium No. 1	SMIC-1021-A	
	-15 °C and -40 °C	***	Lithium Based	WSA-M1C160-D2 SS-M13PI2-A	
<b>REFRIGERANT GAS</b>	ALL FMAX VEHICLES	790 G	J2776	WSH-M17B19-A	
<b>A/C LUBRICANT</b>	ALL FMAX VEHICLES	175 -0/+10 cc		WSH-M1C231-B	
<b>FUEL</b>	ALL FMAX VEHICLES		TS EN590		

(\*): Engine coolant antifreeze rate must be 50% at least.

(\*\*): Use as much as required.

(\*\*\*): Lithium based grease's spec between -15 °C and -40 °C

# TECHNICAL SPECIFICATIONS

## Engine Specifications

12.7 LT 500 PS	
Number of cylinders	6
Displacement	12700cc
Bore	130 mm
Compression ratio	17 / 0.5 /1
Minimum Engine Speed Without Load	550 ± 10
Maximum Engine Speed With Load	1800 ± 20
Valve Clearance	Intake: 0.4mm
	Exhaust: 2.4mm
Ignition Sequence	1-5-3-6-2-4
Turbo	Borgwarner BV70 with variable geometry
Oil Pressure (100 °C)	600 rpm: 0.7 - 2 bar
	1100 rpm: 2.1 - 3bar
	Max speed: 6 bar
Engine brake	30 kW/l (2400 rpm)
Torque per unit liter	
PS per unit liter	

6



# TECHNICAL SPECIFICATIONS

## Transmission Specifications

### Transmission gear ratios

16 S 2600 AMT DD					
	LOW	HIGH RANGE		LOW	HIGH RANGE
1ST GEAR	17,03	14,11	5ST GEAR	3,77	3,12
2ST GEAR	11,99	9,93	6ST GEAR	2,65	2,2
3ST GEAR	7,98	6,61	7ST GEAR	1,76	1,46
4ST GEAR	5,46	4,52	8ST GEAR	1,21	1
			REVERSE GEAR 1	-15,14	-12,54
			REVERSE GEAR 2	-3,35	-2,77

12 TX 2620 TD					
	LOW	HIGH RANGE		LOW	HIGH RANGE
1ST GEAR	16.688	12.924	5ST GEAR	2.174	1.684
2ST GEAR	9.926	7.688	6ST GEAR	1.291	1
3ST GEAR	5.895	4.565	REVERSE GEAR	15.537	12.033
4ST GEAR	3.655	2.831			

# TECHNICAL SPECIFICATIONS

## Installation of Upper structure

You can access the web portal designed to be a guide for Ford Trucks upper structure manufacturers from the following address:  
<https://www.fordtrucksbodybuilderportal.com>

Portal requires a membership and provides the following:

- Urgent info bulletins
- Superstructure forms
- Technical bulletins
- Type approvals
- 2D and 3D technical drawings and models
- Vehicle specification sheets
- Electric and air outlet diagrams
- Advisory, monitory documents

-List of superstructure builders listed as recommended firm as per the inspections of Ford Otosan.

Visit

“Ford Otosan contact information” tab on the  
<https://www.fordtrucksbodybuilderportal.com>  
website to contact relevant persons for your questions.

For your questions on the portal, you may use the following address  
[qvmhelp@ford.com.tr](mailto:qvmhelp@ford.com.tr).

# TECHNICAL SPECIFICATIONS

## Installation of Upper structure

### Dear Upfit / Trailer Manufacturer,

This bulletin is prepared for describing the upfit and trailer electrical connection points and the details of those connections of the Ford Trucks Fmax vehicles.

There are 2 upfit connectors in the cabin and 1 on the chassis arm in the Fmax Trucks.

Other than those connectors, there is 1 FMS (Fleet Management System) Connector in the cabin.

The standart trailer electrical connections to be continued to be given at the back of the cabin.

All the electrical components to be connected later on to the vehicle must have EDE R10 certificate and the proper IP class of them must be choosen properly.

(For example, if the component is to be added to the chassis side, the proper IP class must be choosen as IP67, preferably IP69K.)

The locations and pin details of the connectors left for trailer and upfit connections on the vehicle are shown in the below figures and tables;

### 1. The Upfit Electrical Connector in the Cabin:



The location of the upfit connector located in the fusebox room

# TECHNICAL SPECIFICATIONS

## Installation of Upper structure

Cabin Aftermarket Connector	Aftermarket Kit	AUST 14489 PAA	209/377-1(Tyco)	FEMALE	
	Vehicle Harness Side	AUST-14A459-PA	2098380-1(Tyco)	MAU	

6

Pin no.	Pin Name	Fuse No.	Fuse Amperage	Signal
1	Park Lamp	FUSE 59	10 Amp	+24V
2	IGN-KL15	FUSE 80	15 Amp	+24V
3	SPARE	Linked to Trailer Connector PIN14 *SPARE		
4	GROUND	-		
5	Cruise Control - Set +	-		+24V
6	Cruise Control - Set -	-		+24V
7	HORN	FUSE 43	15 Amp	+24V
8	Alternator - D+	-		+2,7V— +24 V
9	NOT USED	-		
10	Power- KL30	FUSE 52	20 Amp	+24V
11	SPARE	Linked to Trailer Connector PIN11 *SPARE		
12	SPARE	Linked to Trailer Connector PIN10 *SPARE		
13	NOT USED	-	-	-
14	SPARE	Linked to Trailer Connector PIN15 *SPARE		
15	Alternator - W	FUSE 58	3 Amp	-IV — +30 V
16	GROUND	-	-	-
17	l-CAN High	-	-	-
18	l-CAN Low	-	-	-
19	Engine Stop	RELAY 07	20 Amp	+24V
20	NOT USED	-	-	-

The pin distribution and pin details of the upfit connector located in the fusebox room

# TECHNICAL SPECIFICATIONS

## Installation of Upper structure

To be able to reach the cabin upfit connector, the cover of the fusebox room must be removed by pulling delicately from the bottom side of the cover. Then the fusebox room is reached.



Because the cabin upfit electrical connector is behind the fusebox, to be able to reach the connector, the fusebox must be removed by untightening the bolts distributed to four corners of the fusebox. After the 4 bolts and the fusebox removed, the cabin upfit connector is to be reached as shown in the photo below.

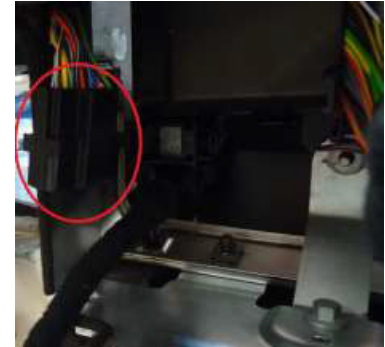
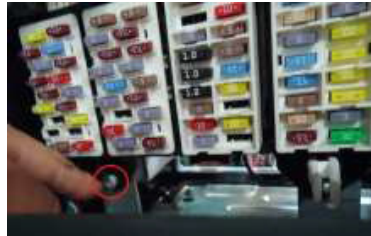

Cabin Upfit Electrical Connector



# TECHNICAL SPECIFICATIONS

## Installation of Upper structure

### 2. Roof Upfit Electrical Connector:



The location of the upfit electrical connector located in the roof of the cabin.

3	Roof Aftermarket Connector	Aftermarket Kit	4S7T-14489-VJA	7283-6455-40; (YAZAKI)	FEMALE	
		Vehicle Harness Side	4S7T-14A459-VJA	7282-6455-40 (YAZAKI)	MALE	

Pin no.	Pin Name	Fuse No.	Fuse Amperage
1	GROUND	-	
2	NOT USED	-	
3	NOT USED	-	
4	IGN - KL15	FUSE 80	15 Amp
5	Power - KL30	FUSE 48	20 Amp
6	NOT USED	-	
7	Tachograph B7	-	
8	Park Lamp	FUSE 16	15 Amp
9	NOT USED	-	
10	NOT USED	-	

The pin distribution and details of the upfit electrical connector located in the roof of the cabin.

# TECHNICAL SPECIFICATIONS

## Installation of Upper structure

The roof upfit electrical connector is located inside the tacograph and the near cover.

To be able to reach that connector, the purple colored part shown in Figure-6 must be removed.

To be able to remove this part, the purple colored parts shown in the Figures-1, 2, 3, 4 and 5 must be removed and taken out sequentially.

After that, the purple colored part shown in the Figure-6 must be taken out.

As a result, the connector is reached from the bottom side of the frame of that taken out purple part, as shown in the Figure-7.



Figure-1



Figure-2



Figure-3

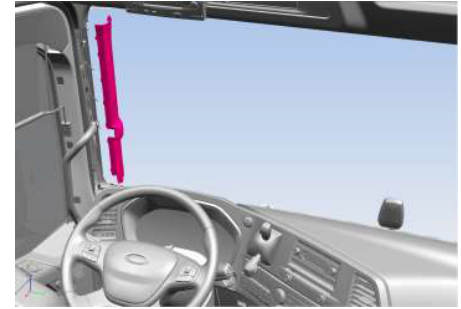

Figure-4

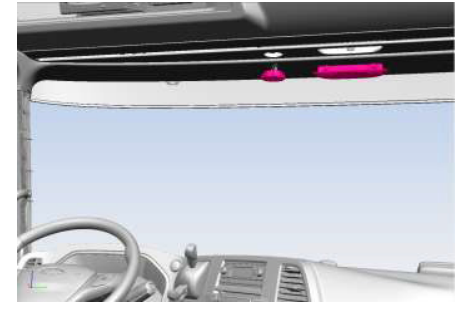

Figure-5

# TECHNICAL SPECIFICATIONS

## Installation of Upper structure

6

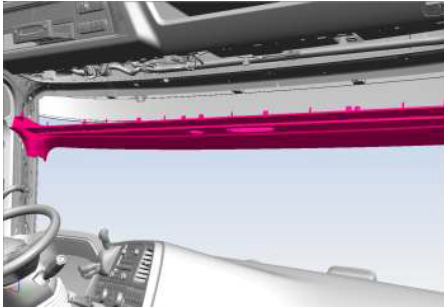

Figure-6



Roof Upfit Electrical Connector

### 3. FMS (Fleet Management System) Connector:

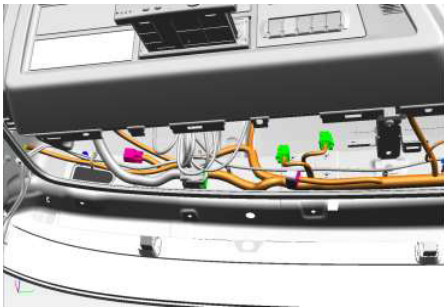
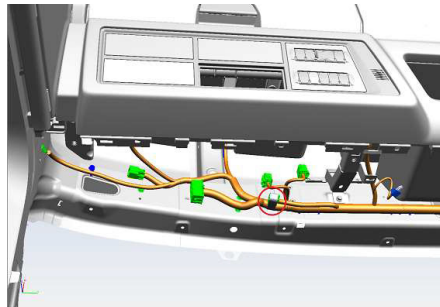

Figure-7





# TECHNICAL SPECIFICATIONS

## Installation of Upper structure

There is a FMS (Fleet Management System) connector inside the cabin of the Ford Trucks Fmax vehicles other than the upfit connector.

The location of the FMS connector which is in the cabin and under the roof is given in the above figure.

FMS Connector	Vehicle Harness Side	JU5T-14489-CEA	1 967622-1(Tyco)	FEMALE	
	Telematik ECU side		1-967627-1(Tyco)	MALE	

6

Pin no,	Pin Name	Fuse No.	Fuse Amperage
1	GROUND	-	-
2	VEHICLE GUARDIAN	-	-
3	NOT USED	-	-
4	NOT USED	-	-
5	NOT USED	-	-
6	I-CAN High	-	-
7	NOT USED	-	-
8	NOT USED	-	-
9	I-CAN Low	-	-
10	IGN-KL15	FUSE 80	15 Amp
11	NOT USED	-	-
12	Power -KL30	FUSE 52	20 Amp

The pin distribution and details of the FMS connector located in the cabin and under the roof.

# TECHNICAL SPECIFICATIONS

## Installation of Upper structure

The way of reaching the FMS Connector is the same as the upfit roof connector shown in Figure-1, 2, 3, 4, 5 and 6. As the roof upfit connector described in section-2, after the purple colored part shown in Figure-6 is removed, the FMS connector can be reached from the bottom corridor shown in Figure-8.

6

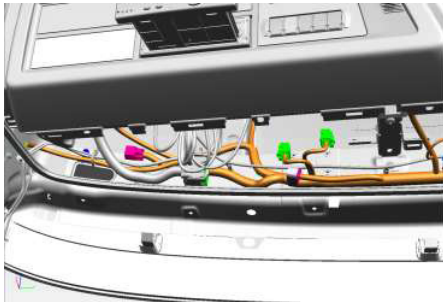
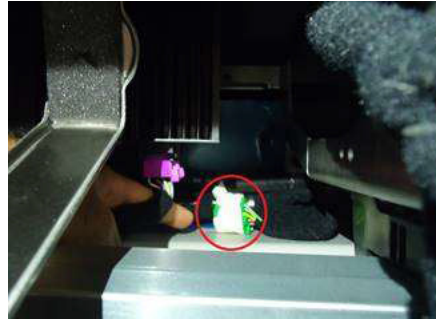
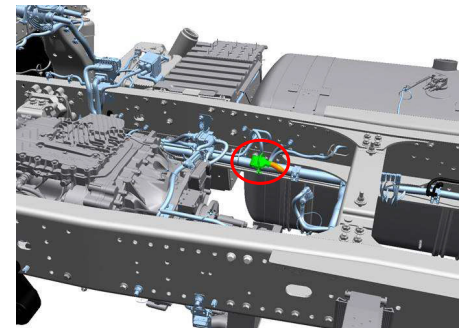

Figure-8



FMS (Fleet Management System)  
Connector

### 4. Chassis Upfit Electrical Connector:



The location of the upfit connector on the  
chassis arm

# TECHNICAL SPECIFICATIONS

## Installation of Upper structure

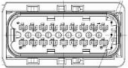
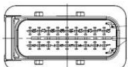
Chassis Aftermarket Connector	Aftermarket Kit	JU5T-14A464-HAA	1-1563759-1(Tyco)	FEMALE	
	Vehicle Harness Side	JU5T-14A624-TA	1-1564412-1(Tyco)	MALE	

Pin no.	Pin Name	Fuse No.	Fuse Amperage	Signal
1	Park Lamp	FUSE 59	10 Amp	+24V
2	IGN-KL15	FUSE 80	15 Amp	+24V
3	Power- KL30	FUSE 48	20 Amp	+24V
4	GROUND	-		
5	Cruise Control - Set +	-		+24V
6	Cruise Control - Set -	-		+24V
7	Cruise Control - Resume	-		+24V
8	GROUND	-		
9	Cruise Control - OFF	-		+24V
10	HORN	FUSE 43	15 Amp	+24V
11	Alternator - W	FUSE 58	3 Amp	-1V +30 V
12	Engine Stop	RELAY 07	20 Amp	+24V
13	NOT USED	-		
14	NOT USED	-		
15	NOT USED	-		
16	NOT USED	-		
17	NOT USED	-		
18	NOT USED	-		

The pin distribution and details of the upfit connector on the chassis arm.

The chassis upfit electrical connector can be reached easily from the inside of the fuel tank, in the chassis arm, as shown in the below photos.

# TECHNICAL SPECIFICATIONS

## Installation of Upper structure



Chassis Bodybuilder Connector:

**Important Note-1:** There is no interconnection between the cabin and chassis connectors.

### 5. Trailer Electrical Connections:

Other than the upfit electrical connectors, there are 2 trailer connectors available in the Ford Trucks Fmax vehicles. The pin distribution and details of these connectors are given in the below figures and table.

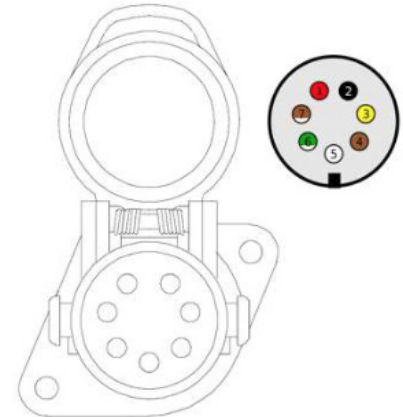

# TECHNICAL SPECIFICATIONS

## Installation of Upper structure

Pin no.	Pin Name	Fuse No.	Fuse Amperage	Max. Power
1	TURN INDICATOR LEFT	-	-	100 W
2	TURN INDICATOR RIGHT	-	-	100W
3	REAR FOG LAMP	-	-	100 W
4	GROUND	-	-	-
5	REAR LAMP LEFT	FUSE 59	10 Amp	240 W TOTAL (INCL CABIN AND CHASSIS AFTERMARKET PARK LAMPS)
6	REAR LAMP RIGHT			
7	STOP LAMP	FUSE 23	10 Amp	150 W
8	BACKUP LAMPS	FUSE 85	10 Amp	150W
9	DAMPER SWITCH	-	-	-
10	SPARE	Linked to Cabin Aftermarket Connector *PIN12		
11	SPARE	Linked to Cabin Aftermarket Connector *PIN11		
12	TRAILER TAG AXLE LIFTING	-	-	-
13	GROUND	-	-	-
14	SPARE	Linked to Cabin Aftermarket Connector *PIN3		
15	SPARE	Linked to Cabin Aftermarket Connector *PIN14		

Pin no	Pin Name	Fuse No.	Fuse Amperage
1	Power- KL30	FUSE 31	30 Amp
2	IGN-KL15	FUSE 88	7.5 Amp
3	GROUND	-	-
4	GROUND	-	-
5	TRAILER DETECTION SWITCH		
6	TRAILER CAN H	-	-
7	TRAILER CAN L	-	-

# TECHNICAL SPECIFICATIONS

## Installation of Upper structure

### 6. Additional Engine RPM Indicator (Tachometer) Connection:

For this purpose, “W” signal of the cabin or chassis electrical connector can be used.

The way of how to use the “W” signal is shown below.

The maximum ampere in the W Terminal  
 $A = 0,5 A$

The average of the pulse onset voltage must be  $VMH = +30 V / VWL = -1 V$   
The engine RPM value can be obtained by using the below formula, with the initial value of the alternator turning speed. The found value is modified according to the pulley diameter ratio of the alternator and the engine crankshaft. The below is the frequency of the fW W-Terminal in Hertz.

Alternator RPM (rpm) =  $10 \times fW$   
Engine RPM (rpm) = alternator RPM (rpm)  $\times$  pulley value

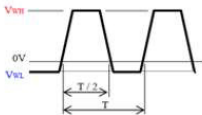

Below calculations to be used when an output is taken from the alternator D+ Terminal;

Max sink current  $A = 0.3 A$   
In 0.3 Ampere, maximum terminal current =  $2.7 A$   
Maksimum output voltage =  $24 V$

### 7. The usage of D+ signal:

The usage of D+ Terminal is described below:

The warning light and control unit is connected to the D+ terminal.  
If the regulator catches an error in the alternator (when the alternator is not working), the regulator decreases the potential of the D+ terminal to “LO Level” and then it results in turning the warning light on of the D+ terminal.  
While the alternator is working properly, the warning light keeps off. In this case, the regulator can feed an outsource power via this terminal.

# TECHNICAL SPECIFICATIONS

## Installation of Upper structure

### 8. Warnings:

All the electrical components to be connected to the vehicle later on, must be connected via the upfit electrical connectors with the appropriate mounting conditions described above. For example, the cable should not be cut and connected again, isolating tapes should not be used and the cables must not be left ordinarily and untidily. Some improper usage examples are shown in the below photos. In such improper situations, the vehicle guarantee may drop.

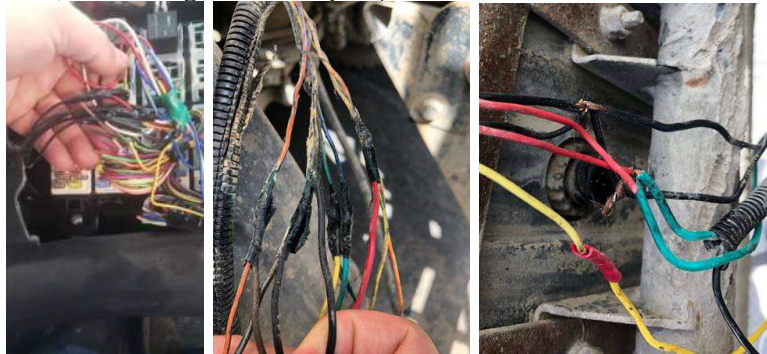

**Improper cable connection examples**

**Important Note-2:** Keeping in mind it is not suggested to make a welding operation on the vehicle directly, if it becomes a must, initially the battery master switches must be turned off and the battery pole covers must be removed.

# AUXILIARY HEATER

## Airtronic/Airtronic M

### Special text structure, presentation and picture symbols

This manual uses special text structures and picture symbols to emphasise different contents. Please refer to the examples below for the corresponding meanings and associated actions.

### Special structure and presentations

A dot (·) indicates a list which is started by a heading. If an indented dash (–) follows a dot, this list is subordinate to the dot.

### Picture symbols



#### REGULATION!

This picture symbol with the remark “Regulation” refers to a statutory regulation. Failure to comply with this regulation results in expiry of the type permit for the heater and preclusion of any guarantee and liability claims on Eberspächer Climate Control Systems GmbH and its associated companies.



#### DANGER!

This picture symbol with the remark

“Danger!” refers to the risk of a fatal danger to life and limb. Under certain circumstances, failure to comply with these instructions can result in severe or life-threatening injuries



#### CAUTION!

This picture symbol with the remark “Caution!” refers to a dangerous situation for a person and / or the product. Failure to comply with these instructions can result in injuries to people and / or damage to machinery.



#### Please note!

These remarks contain application recommendations and useful tips for installation of the heater.

Important information before starting work

### Range of application of the heater

The air heater operating independently of an engine is intended for installation in the following vehicles, depending on its heating output:

- All types of vehicles (max. 8 seats + driver's seat) and their trailers
- Construction machinery

- Agricultural machinery
- Boats, ships and yachts (only diesel heaters)
- Camper vans



#### Please note!

- The heaters (only diesel heaters, 24 volt) can be installed in vehicles used for the transport of dangerous goods as per ADR.
- The current controller is to be replaced by a special controller when the heater is to be used to heat the freight compartment / cargo (order no. see heater price list or spare parts list).
- The „Plus“ installation kits are intended for installation in a camper van.

### Purpose of the heater

- Pre-heating, de-misting windows
- Heating and keeping the following warm:
  - Driver and working cabs, Ship's cabins
  - Freight compartments
  - Passenger and crew compartments
  - Camper vans

On account of its functional purpose, the heater is not permitted for the following applications: for the following applications:

- Long-term continuous operation, e.g. for preheating and heating of
  - Residential rooms
  - Garages



# AUXILIARY HEATER

## Airtronic/Airtronic M

- Work huts, weekend homes and hunting huts
- Houseboats, etc.
- Heating or drying:
- Living creatures (people or animals) by blowing hot air directly at the subject
- Objects
- Blowing hot air into containers





### CAUTION!

### Safety instructions for application and proper purpose

- The heater must only be used and operated for the range of application stated by the manufacturer in compliance with the “Operating instructions” included with every heater.

### Statutory regulations

The Federal Motor Transport Authority has issued an approval for a component according to ECE R122 and ECE-R10 for the heater for installation in motor vehicles, with the following official typeapproval markings noted on the heater’s nameplate.

Heater type:	ECE type approval mark:
Airtronic	 122 R – 000025 10 R – 051516
Airtronic M	 122 R – 000026 10 R – 051653



### REGULATION!

### Excerpt from ECE regulation No. 122 of the European Parliament and the Council

#### General regulations

##### • Operating state display

- A clearly visible operating display in the user’s field of vision must indicate when the heater is switched on and off.

#### Regulations concerning installation in the vehicle

##### • Scope

- Subject to differing stipulations in the following section, combustion heaters must be installed according to the regulations 5.3 of ECE-R122.
- It is assumed that Class O vehicles with heaters for liquid fuel conform to the regulations 5.3 of ECE-R122.

##### • Arrangement of the heater

- Parts of the structure and other components near the heater must be protected from excessive heat exposure and possible fuel or oil contamination.
- The heater must not pose a fire hazard even when it over-heats. This requirement is deemed to be fulfilled if adequate clearance is ensured for all parts during installation, sufficient ventilation is provided and fireproof materials or heat shields are used.
- The heater must not be mounted in the passenger compartment of vehicles in class M<sub>2</sub> and M<sub>3</sub>. However, a heater in a hermetically sealed enclosure which also complies with the aforementioned conditions may be used.
- The factory nameplate or duplicate must be affixed so that it can still be easily read when the heater is installed in the vehicle.
- All appropriate precautions must be taken when arranging the heater to minimise the risk of injuries to persons or damage to other property.
- Fuel supply
  - The fuel intake connection must not be located in the passenger compartment and must be sealed with a properly

# AUXILIARY HEATER

## Airtronic/Airtronic M

- closing lid to prevent any fuel leaks.
- In heaters for liquid fuel where the heater fuel is separate from the vehicle fuel, the type of fuel and intake connection must be clearly identified.
  - A warning sign is to be fixed to the intake connection indicating that the heater must be switched off before refuelling.
  - **Exhaust system**
    - The exhaust outlet must be arranged so as to prevent any penetration of exhaust fumes into the vehicle interior through the ventilation system, warm air intakes or open windows.
  - **Combustion air intake**
    - The air for the heater's combustion chamber must not be sucked in from the vehicle's passenger compartment.
    - The air intake must be arranged or protected in such a way that it cannot be blocked by other objects.
  - **Hot air intake**
    - The heater's air supply must consist of fresh air or circulated air and must be sucked in from a clean area, which cannot be contaminated by exhaust fumes from the engine, the combustion heater or any other source in the vehicle.
    - The intake pipe must be protected by a

grid or other suitable means.

- **Hot air outlet**
  - The hot air pipes within the vehicle must be arranged or protected in such a way that there is no risk of injury or damage if they are touched.
  - The air outlet must be arranged or protected in such a way that it cannot be blocked by any objects.
- **Automatic control of the heating system**
  - If the engine fails, the heating system must be automatically switched off and the fuel supply stopped within 5 seconds. The heater may remain in operation if a manual device has already been activated.

§

### REGULATION!

#### **Additional regulations for certain vehicles named in Directive 94/55/EC of the ADR Agreement**

##### **Scope**

This appendix applies to vehicles for which the special provisions of Directive 94/55/EC apply to combustion heaters and their installation.

##### **Definition of terms used**

The vehicle designations "EX / II", "EX / III", "AT", "FL" and "OX" according to Chapter 9.1 of the ADR Agreement Directive 94/55/EC are used for the purposes of this annex.

##### **Technical regulations**

##### **General provisions (EX / II, EX / III, AT, FL and OX vehicles)**

##### **Avoid heating and ignition**

Combustion heaters and their exhaust pipes must be designed, arranged, protected or covered so that any unacceptable risk of heating or ignition of the load is avoided. This regulation is deemed to be complied with if the fuel tank and the exhaust system of the unit conform to the regulations described in the "Fuel tank" and "Exhaust system and exhaust pipe layout" paragraphs. The complete vehicle must be checked for compliance with these regulations.

##### **Fuel tanks**

Fuel tanks for supplying the heater shall conform to the following regulations:

- In the event of any leakage, the fuel shall

# AUXILIARY HEATER

## Airtronic/Airtronic M

drain to the ground without coming into contact with hot parts of the vehicle or the load;

- fuel tanks containing petrol shall be equipped with an effective flame trap at the filler opening or with a closure enabling the opening to be kept hermetically sealed.

### **Exhaust system and exhaust pipe layout**

The exhaust system as well as the exhaust pipes shall laid out or protected to avoid any danger to the load through heating or ignition. Parts of the exhaust system situated directly below the fuel tank (diesel) shall have a clearance of at least 100 mm or be protected by a thermal shield. Switching on the combustion heater The combustion heater may only be switched on manually. Automatic switching on via a programmable switch is not permitted.

### **EX / II and EX / III vehicles**

Combustion heaters for gaseous fuels are not permitted.

### **FL vehicles**

Combustion heaters must be able to be

taken out of service/disabled at least by the methods described in the following:

- a) Switching off manually in the driver's cabin
- b) Switching off the vehicle's engine; in this case the heater may be manually switched back on by the vehicle driver;
- c) Starting up of a feed pump installed in the vehicle for the dangerous goods carried. Combustion heater after-run After-running of the switched off combustion heater is permitted. In the cases named in the „FL vehicles“ paragraph under letters b) and c) the supply of combustion air must be interrupted by suitable means after a maximum after-run period of 40 seconds. Only combustion heaters whose heat exchangers are verifiably not damaged by the reduced after-run period of 40 seconds beyond their usual use period may be used.



### **Please note!**

- Compliance with the statutory regulations, the additional regulations and safety instructions is prerequisite for guarantee and liability claims. Failure to

comply with the statutory regulations and safety instructions and incorrect repairs even when using original spare parts make the guarantee null and void and preclude any liability for Eberspächer Climate Control Systems GmbH.

- Subsequent installation of this heater must comply with these installation instructions.
- The statutory regulations are binding and must also be observed in countries which do not have any special regulations.
- When the heater is to be installed in vehicles not subject to the German Ordinance for the Registration of Motor Vehicles (StVZO), for example ships, the specially valid regulations and installation instructions for these special applications must be observed.
- Installation of the heater in special vehicles must comply with the regulations applying to such vehicles
- Other installation requirements are contained in the corresponding sections of this manual.

# AUXILIARY HEATER

## Airtronic/Airtronic M

### Safety instructions for installation and operation



#### **DANGER!**

#### **Risk of injury, fire and poisoning!**

- The heater must only be started up when the maintenance flap is closed and the outlet hood is mounted in position.
- The maintenance flap must not be opened during operation.
- Disconnect the vehicle battery before commencing any kind of work.
- Before working on the heater, switch the heater off and let all hot parts cool down.
- The heater must not be operated in closed rooms, e.g. in the garage or in a multi-storey car park.
- Adjustable hot air outlets must always be adjusted so that they cannot blow hot air directly at living creatures (people, animals) or objects sensitive to temperature (loose and / or fastened).



#### **CAUTION!**

### Safety instructions for installation and operation!

- The year of initial commissioning must be marked on the nameplate.
- The heat exchanger of air heaters is a component subject to high thermal loads which must be replaced 10 years after initial commissioning of the heater. In addition, the installation date must be entered on the plate "original spare part" enclosed with the heat exchanger must. Then affix the plate next to the nameplate on the heater.
- The heater must only be installed by a JE partner authorised by the manufacturer according to the instructions in this manual and possibly according to special installation recommendations; the same applies to any repairs to be carried out in the case of repairs or guarantee claims.
- Only the control elements approved by Eberspächer Climate Control Systems GmbH. must be used to operate the heater. The use of other control elements can cause malfunctions.
- Repairs by unauthorised third-parties or with not original spare parts are dangerous and therefore not allowed. They result in expiry of the type permit of the heater; consequently, when installed in motor vehicles they can cause expiry of the vehicle operating licence.
- The following measures are not allowed:
  - Changes to components relevant to the heater.
  - Use of third-party components not approved by Eberspächer.
- Nonconformities in installation or operation from the statutory regulations, safety instructions or specifications relevant to safe operation as stated in the installation instructions 1 Introduction and operating instructions. This applies in particular to the electrical wiring, fuel supply, combustion air system and exhaust system.
- Only original accessories and original spare parts must be used during installation or repairs.
- When carrying out electric welding on the vehicle, the plus pole cable at the battery should be disconnected and placed at ground to protect the controller.
- Do not operate the heater anywhere where there are readily flammable materials (e.g. dry grass, leaves, paper, etc.) in the area of the exhaust system or where ignitable fumes and dust can form, e.g. near a
  - fuel depot
  - coal depot
  - wood depot
  - grain depots, etc.
- The heater must be switched off when refuelling.
- When the heater is mounted in a safety housing etc., the installation compartment of the heater is not a

# AUXILIARY HEATER

## Airtronic/Airtronic M

stowage compartment and must be kept clear. In particular fuel canisters, oil cans, spray cans, gas cartridges, fire extinguishers, cleaning rags, items of clothing, paper etc. must not be stored or transported on or next to the heater.

- Defect fuses must only be replaced by fuses with the prescribed rating.
- If fuel leaks from the heater fuel system, arrange for the damage to be repaired immediately by a JE service partner.
- After-running of the heater must not be interrupted prematurely e.g. by pressing the battery disconnecting switch, apart from in the case of an emergency stop.



### **Please note!**

Following installation, attach the „Switch off heater before refuelling!“ sticker near the tank filler neck.

### **Accident prevention**

General accident prevention regulations and the corresponding workshop and operation safety instructions are to be observed.

# AUXILIARY HEATER

## Airtronic/Airtronic M

### Heater scope of supply, complete packages and universal installation kit

Heater	Order No
Airtronic D2, 12 V	25 2069 05 00 00
Airtronic D2, 24 V	25 2070 05 00 00
Airtronic B3 Plus, 12 V	20 1944 05 00 00
Airtronic D3, 12 V	25 2317 05 00 00
Airtronic B4, 12 V	20 1812 05 00 00
Airtronic D4, 12 V	25 2113 05 00 00
Airtronic D4, 24 V	25 2114 05 00 00
Airtronic D4 Plus, 12 V	25 2484 05 00 00
Airtronic D4 Plus, 24 V	25 2498 05 00 00

The scope of supply includes:

Figure No	Name
1	Heater
2	Metering pump

### Complete Airtronic D2 Order No. package

Order No.	Order No.
12 V with EasyStart Select	25 2675 05 00 00
24 V with EasyStart Select	25 2676 05 00 00

Included in the scope of supply:

Figure No	Name
1	Heater
2	Metering pump
-	Installation kit with outlet hood Ø 60 mm
3	EasyStart Select
4	Tank connection (only in complete package Airtronic D2, 24 V)

Universal installation kit (all versions)

Included in the scope of supply:

Figure No	Name
5	Lead harness, plus / minus (included in Item 22)
6	Lead harness, operation (included in Item 22)
7	Flexible exhaust pipe, 1 m long
8	Combustion air hose, 1 m long
9	Cable tie (2x10)
	Bracket, metering pump
11	Pipe, 6 x 2, 1.5 m long
12	Pipe, 4 x 1.25, 7.5 m long
13	Hose clip (1x)
14	Air outlet 30°, Ø 75 mm / Ø 90 mm
15	Connection socket, Ø 75 mm / Ø 90 mm
16	Air outlet, upward 30°, Ø 60 mm

# AUXILIARY HEATER

## Airtronic/Airtronic M

17	Connection socket Ø 60 mm
18	Grid
19	Hood
20	Flexible pipe
21	Exhaust silencer
22	Cable harness, heater

Using the universal installation kits

Order No.

### Universal installation kit 25 2069 80 00 00

- with outlet hood Ø 60 mm, heater guide number 6, usable with:
  - Airtronic D2, 12 V 25 2069 05 00 00
  - Airtronic D2, 24 V 25 2070 05 00 00

### Universal installation kit 25 2113 80 00 00

- with outlet hood Ø 90 mm, heater guide number 10, usable with:

- Airtronic D3, 12 V 25 2317 05 00 00
- Airtronic B4, 12 V 20 1812 05 00 00
- Airtronic D4, 12 V 25 2113 05 00 00
- Airtronic D4, 24 V 25 2114 05 00 00

- with outlet hood Ø 90 mm, heater guide number 15, usable with:

- Airtronic D4 Plus, 12 V 25 2484 05 00 00
- Airtronic D4 Plus, 24 V 25 2498 05 00 00

- with outlet hood Ø 90 mm, heater guide number 30, usable with:

- Airtronic B3 Plus, 12 V 20 1944 05 00 00

### Universal installation kit 25 2484 80 00 00

- with outlet hood Ø 75 mm, heater guide number 3, usable with:
  - Airtronic D3, 12 V 25 2317 05 00 00
  - Airtronic B4, 12 V 20 1812 05 00 00
  - Airtronic D4, 12 V 25 2113 05 00 00
  - Airtronic D4, 24 V 25 2114 05 00 00

- with outlet hood Ø 75 mm, heater guide number 8, for recirculation mode heater guide number 10, for fresh air mode usable with:
  - Airtronic B3 Plus, 12 V 20 1944 05 00 00
  - Airtronic D4 Plus, 12 V 25 2484 05 00 00
  - Airtronic D4 Plus, 24 V 25 2498 05 00 00



### Please note!

- Control elements see price list or product information.
- Parts without a figure no. are small parts and packed in a bag.
- If other parts are required for the installation, see product information.
- For notes on the unit ratings, refer to product information

# AUXILIARY HEATER

## Airtronic/Airtronic M

Scope of supply: Heater, universal installation kit and complete packages

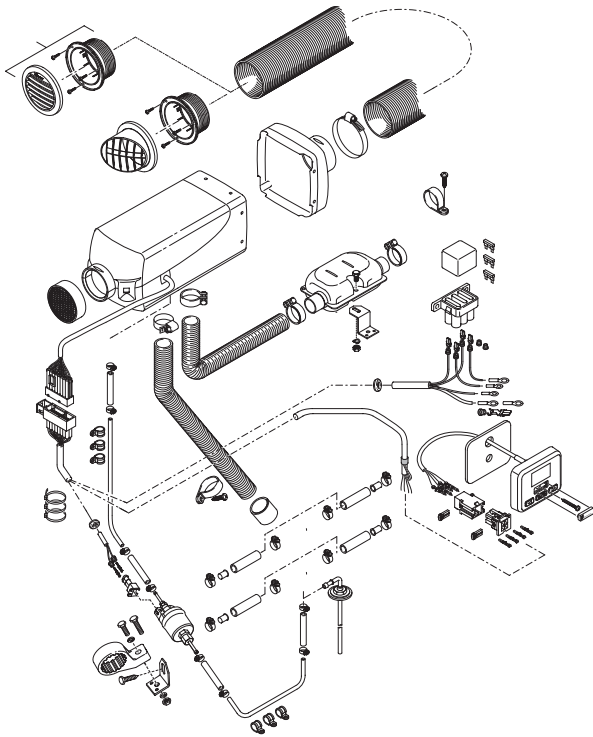

- \* Only included in the complete Airtronic D2 package.
- \*\* Only included in the complete Airtronic D2, 24 volt package.
- \*\*\* Only included in the installation kit for the Airtronic D2 and in the complete Airtronic D2 package.
- \*\*\*\* Only included in the installation kit for the Airtronic B3 Plus, D3, B4, D4, D4 Plus.



# AUXILIARY HEATER

## Airtronic/Airtronic M

### Scope of supply Heater and "Plus" installation kit

Heater	Order No
Airtronic D2, 12 V	25 2069 05 00 00
Airtronic D2, 24 V	25 2070 05 00 00

The scope of supply includes:

Figure No.	Name
1	Heater
2	Metering pump

"Plus" installation kit 25 2113 82 00 00

- with outlet hood Ø 75 mm, heater guide number 12,

The scope of supply includes:

Figure No.	Name
3	Combustion air intake silencer
4	Exhaust silencer
5	Connection socket, Ø 60 mm (3x)

6	Air outlet 0°, Ø 60 mm	20	Bracket metering pump
7	Y-pipe Ø 75/60/60 mm	21	Cable tie (2x10)
8	Tank connection kit	22	Hood Ø 75 mm
9	Temperature control sensor	23	Air outlet 30°, Ø 60 mm
10	Cable loom for temperature control sensor	24	Adapter Ø 6 / 4
11	Flexible tubing, Ø 75 mm (is not supplied)	25	Pipe 4 x 1, 6 m long, (included in Item 8)
12	Lead harness, plus / minus (included in Item 17)	26	Pipe clip, Ø 50 mm
13	Lead harness, operation (included in Item 17)	27	Flexible pipe Ø 60 mm for hot air system (is not supplied)
14	Hose clip Ø 60 mm (2x)		
15	Hose clip Ø 75 mm (2x)		
16	Pipe 4 x 1.25 , 6 m long, (included in Item 8)		
17	Cable harness, heater		
18	Flexible exhaust pipe, 1 m long		
19	Grid		



### Please note!

- Parts without a figure no. are small parts and packed in a bag.
- If other parts are required for the installation, see product information.
- For notes on the unit ratings, refer to product information.
- The "Plus" installation kits are particularly suitable for installations in camper vans and boats.



# AUXILIARY HEATER

## Airtronic/Airtronic M

### Technical data

Heater type	Airtronic					
Heater	Airtronic D2					
Version	D2					
Heating medium	Air					
Control of the heat flow	Stage					
	Power	Large	Medium	Small	Off	
Heat flow (watt)	2200	1800	1200	850	–	
Heater air flow rate without counterpressure (kg/h)	with hood Ø 60 mm	105	87	60	42	13
Fuel consumption (l/h)		0,28	0,23	0,15	0,10	–
Elektr. power consumption (watt)	in operation	34	23	12	8	4
		at start	≤100			
Rated voltage	12 or 24 volt					
Operating range <ul style="list-style-type: none"> <li>Lower voltage limit: An undervoltage protection in the controller switches off the heater when the voltage limit is reached.</li> </ul>	approx. 10.5 volt resp. 21 volt Undervoltage protection trigger time: 20 seconds					

# AUXILIARY HEATER

## Airtronic/Airtronic M

<ul style="list-style-type: none"> <li>Upper voltage limit: An overvoltage protection in the controller switches off the heater when the voltage limit is reached.</li> </ul>	approx. 16 volt resp. 32 volt Overvoltage protection trigger time: 20 seconds	
Fuel "Fuel quality" and "Fuel at low temperatures" see page 28.	Commercially available diesel fuel (DIN EN 590)	
Tolerable ambient temperature	Operation	Not running
	Heater - 40 °C to +70 °C	- 40 °C to +85 °C
Dosing pump - 40 °C to +50 °C		- 40 °C to +125 °C
Maximum air intake temperature	+40 °C	
Interference suppression	Interference suppression class 5 to DIN EN 55 025	
Weight	approx. 2,7 kg	
Ventilation mode	possible	



### CAUTION!

Safety instructions for technical data!  
Failure to comply with the technical data can result in malfunctions.



### Please note!

Provided no limit values are given, the technical data listed is subject to the tolerances usually applicable to heaters of ±10% for nominal voltage, ambient temperature 20 °C and reference altitude Esslingen.

# AUXILIARY HEATER

## Airtronic/Airtronic M

### Technical data

Heater type		Airtronic M				
Heater		Airtronic D3 / Airtronic D4 / Airtronic D4 Plus				
Version		D3 / D4 / D4 Plus				
Heating medium		Air				
Control of the heat flow		Stage				
		Power	Large	Medium	Small	Off
Heater air flow rate without counterpressure (kg/h)	D3	3000	2200	1600	900	–
	D4	4000	3000	2000	900	–
	D4 Plus	4000	3000	2000	900	–
Heater air flow rate without counterpressure (kg/h)	D3 with hood Ø 90 mm	150	120	90	60	24
	D4 with hood Ø 90 mm	185	150	110	60	22
	D4 Plus with hood Ø 75 mm	185	140	100	55	–
Fuel consumption (l/h)	D3	0,38	0,28	0,24	0,11	–
	D4	0,51	0,38	0,25	0,11	–
	D4 Plus	0,51	0,38	0,25	0,11	–
Elektr. power consumption (watt) in operation (12 and 24 volt)	D3	24	16	10	7	5
	D4	40	24	13	7	5
	D4 Plus	55	30	16	7	5
at start (12 and 24 volt)		≤100				

# AUXILIARY HEATER

## Airtronic/Airtronic M

Rated voltage	12 or 24 volt	
Operating range · Lower voltage limit: An undervoltage protection in the controller switches off the heater when the voltage limit is reached.	approx. 10.5 volt resp. 21 volt Undervoltage protection trigger time: 20 seconds	
· Upper voltage limit: An overvoltage protection in the controller switches off the heater when the voltage limit is reached.	approx. 16 volt resp. 32 volt Overvoltage protection trigger time: 20 seconds	
Fuel "Fuel quality" and "Fuel at low temperatures" see page 28.	Commercially available diesel fuel (DIN EN 590)	
Tolerable ambient temperature	Operation	Not running
Heater	- 40 °C to +70 °C	- 40 °C to +85 °C
Dosing pump	- 40 °C to +50 °C	- 40 °C to +125 °C
Maximum air intake temperature	+40 °C	
Interference suppression	Interference suppression class 5 to DIN EN 55 025	
Weight	approx. 4,5 kg	
Ventilation mode	possible	



**Please note!**

Safety instructions for technical data see page 12.

# AUXILIARY HEATER

## Airtronic/Airtronic M

### Technical data

Heatertyp		Airtronic M					
		Airtronic B3 Plus / Airtronic B4					
Heater		Airtronic B3 Plus / Airtronic B4					
Version		B3 Plus / B4					
Heating medium		Air					
Control of the heat flow		Stage					
		Power	Large	Medium	Small	Off	
Heat flow (watt)	B3 Plus	3000	2300	1700	1200	–	
	B4	3800	3200	2100	1300	–	
Heater air flow rate without counterpressure (kg/h)							
		B3 Plus with hood Ø 90 mm	175	143	115	85	24
		B4 with hood Ø 90 mm	185	160	120	85	24
Fuel consumption (l/h)	B3 Plus	0,43	0,33	0,24	0,16	–	
	B4	0,54	0,46	0,29	0,18	–	
Elektr. power consumption (watt) iin operationt (12 and 24 volt)	B3 Plus	33	20	13	8	5	
	B4	40	29	15	9	5	
	at start	≤100					

# AUXILIARY HEATER

## Airtronic/Airtronic M

Rated voltage	12 volt		
Operating range · Lower voltage limit: An undervoltage protection in the controller switches off the heater when the voltage limit is reached.	approx. 10.5 volt Undervoltage protection trigger time: 20 seconds		
· Upper voltage limit: An overvoltage protection in the controller switches off the heater when the voltage limit is reached.	approx. 16 volt Undervoltage protection trigger time: 20 seconds		
Fuel “Fuel quality“ and “Fuel at low temperatures“ see page 28.	Commercially available petrol fuel (DIN EN 228)		
Tolerable ambient temperature	Operation	Not running	
	Heater	– 40 °C to +50 °C	– 40 °C to +85 °C
	Dosing pump	– 40 °C to +20 °C	– 40 °C to +125 °C
Maximum air intake temperature	+40 °C		
Interference suppression	Interference suppression class 5 to DIN EN 55 025		
Weight	approx. 4,5 kg		
Ventilation mode	possible		



### CAUTION!

#### Safety instructions for technical data!

Failure to comply with the technical data can result in malfunctions.



### Please note!

Provided no limit values are given, the technical data listed is subject to the tolerances usually applicable to heaters of  $\pm 10\%$  for nominal voltage, ambient temperature 20 °C and reference altitude Esslingen.





# AUXILIARY HEATER

## Airtronic/Airtronic M

### Nameplate

The nameplate is fastened to the front of the heater. The second nameplate (duplicate) is included in the scope of supply of the heater.

If required, the duplicate nameplate can be adhered in a clearly visible position on the heater or near to the heater.



### Please note!

The regulations and safety instructions to be observed for this chapter are stated on page 5.

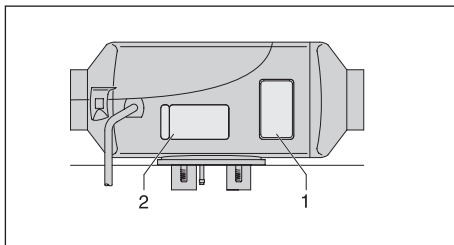

- 1 Original nameplate
- 2 2nd nameplate (duplicate)

### Installation and mounting position

The heater is suitable and approved for installation in vehicle interiors used by people.

The heater, together with its heater angle and the mounted angle seal, is fixed directly onto the floor of the vehicle or in a suitable position in the rear panel of the vehicle.



### Please note!

- If installed inside the vehicle, detachable connections of exhaust gas, combustion air and fuel lines are not allowed.
- The angle seal must be mounted on the heater, in order to seal off the openings for the exhaust gas, combustion air and fuel lines.
- Installation in the driver's cab or passenger compartment of commercial buses with more than 9 seats (8 seats + driver's seat) is not allowed.
- The ADR regulations must also be complied with for installation of the heater in vehicles used to transport dangerous goods. For information on the ADR regulations, see page 6, 31 and in the information sheet with Print No. 25 2161 95 15 80.
- When installing the heater, ensure sufficient open space is allowed for intake of the heating air and for the dismantling of glow plugs and control box (see page

15 "main dimensions").

- Observe the regulations and safety instructions for this chapter, given on pages 4 – 7.

### Installation position in a camper van

In a camper van, the heater is preferably installed in the inner compartment or luggage compartment.

If it is not possible to install the heater in the passenger compartment or boot, the heater can also be mounted, protected against splashing water, under the vehicle floor.



### Please note!

The „Plus“ installation kits are intended for installation in a camper van.

# AUXILIARY HEATER

## Airtronic/Airtronic M

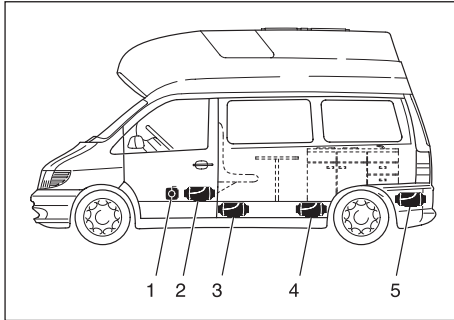

- 1. Heater in front of the passenger seat
- 2. Heater between the driver's seat and the passenger seat
- 3. Heater under the vehicle door
- 4. Heater in living space
- 5. Heater in the boot

### Installation

Installation in a car or people carrier  
In a car or people carrier, the heater is preferably installed in the passenger compartment or boot.  
If it is not possible to install the heater in the passenger compartment or boot, the heater can also be mounted, protected against splashing water, under the vehicle door.

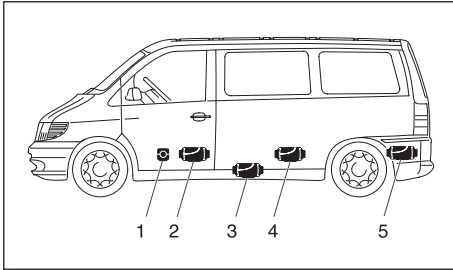

- 1. Heater in front of the passenger seat
- 2. Heater between the driver's seat and the passenger seat
- 3. Heater under the vehicle door
- 4. Heater under the back seat
- 5. Heater in the boot

### Installation in an excavator cab (only diesel heaters)

In an excavator, the heater is preferably installed in the cab. If it is not possible to install the heater in the cab, the heater can also be installed in a storage box outside the cab.

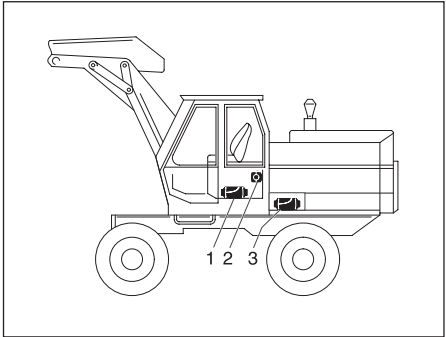

- 1 Heater in the seat box
- 2 Heater on the cab rear wall
- 3 Heater in a protective case

# AUXILIARY HEATER

## Airtronic/Airtronic M

### Installation in a truck (only diesel heaters)

In a truck, the heater is preferably installed inside the driver's cab. If it is not possible to install the heater inside the driver's cab, it can also be mounted in the tool box or in a storage box.

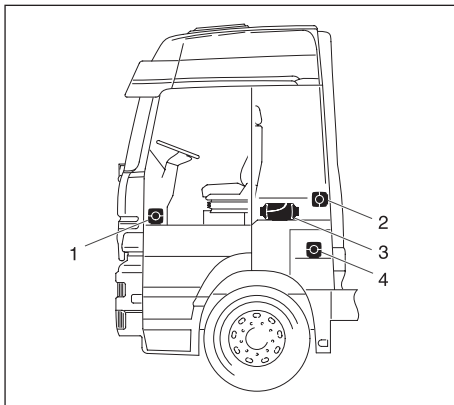

1. Heater in the passenger's foot room
2. Heater on the cab rear wall
3. Heater under the bed
4. Heater in the tool box



### Please note!

- The installation suggestions made in the installation instructions are just examples. Other installation locations are possible, as long as they correspond to the installation requirements stated in these instructions.
- Other installation information (e.g. for boats and ships) is available from the manufacturer on request.
- Observe the tolerable installation position together with the operating and storage temperatures.

### Possible installation positions

The heater is preferably installed in the normal position as shown in the drawing. Depending on the installation conditions, the heater can be tilted by max. 30° (down direction to the bottom) or turned by max. 90° around its own longitudinal axis (exhaust connection horizontal, glow plug points upwards!).



### Please note!

In the heating mode, the heater can deviate from the shown normal or maximum installation positions by up to

+15° in all directions because of a slanting position of the vehicle or boat, without any impaired functions.

# AUXILIARY HEATER

Airtronic/Airtronic M

**Normal position horizontal (exhaust connection downwards)  
with tolerable swivel range**

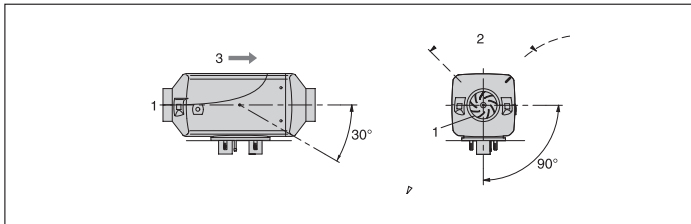

- 1 Heater air intake opening (fan wheel)
- 2 Position of the glow plug
- 3 Direction of flow

## **Cable harness connection, optionally right or left**

If necessary, the cable harness connection can be changed over to the other side of the heater. To do so, the controller has to be removed and the lower semi-circular cable harness cover unclipped.

The cable harness can then be rerouted in the controller. Then mount the controller again, position the jacket shell and insert the cable harness bush and the bungs in the corresponding recesses in the lower jacket shell.

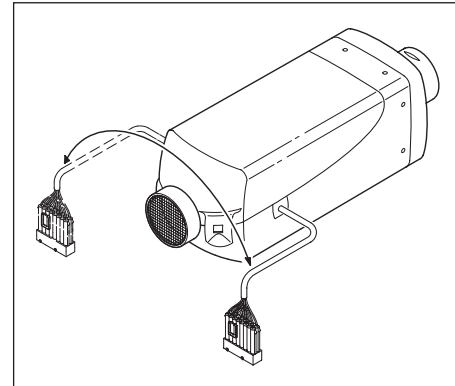

# AUXILIARY HEATER

## Airtronic/Airtronic M

### Mounting and fastening

Make the necessary breakthroughs for exhaust, combustion air and fuel as shown in the hole diagram. The support surface for the heater foot must be flat. An appropriate tool can be purchased from the manufacturer for drilling the breakthroughs and also smoothing the support surface. The hole  $\varnothing 10,5$  mm for the cable harness "dosing pump" is not included in the picture drawing and must be drilled after installation.

### Picture hole

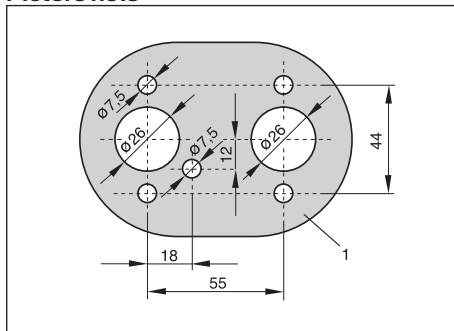

1 Contour of the bearing surface

If the sheet metal of the support surface is  $<1,5$  mm thick, an additional reinforcement must be installed.

Order no: 20 1577 89 00 03  
reinforcement plate

Order no: special tool 99 1201 46 53 29

### Special tool

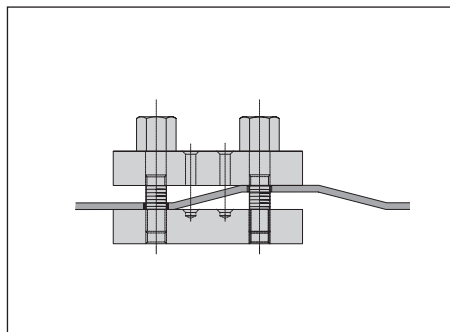

# AUXILIARY HEATER

Airtronic/Airtronic M

## Fastening the unit on the vehicle floor

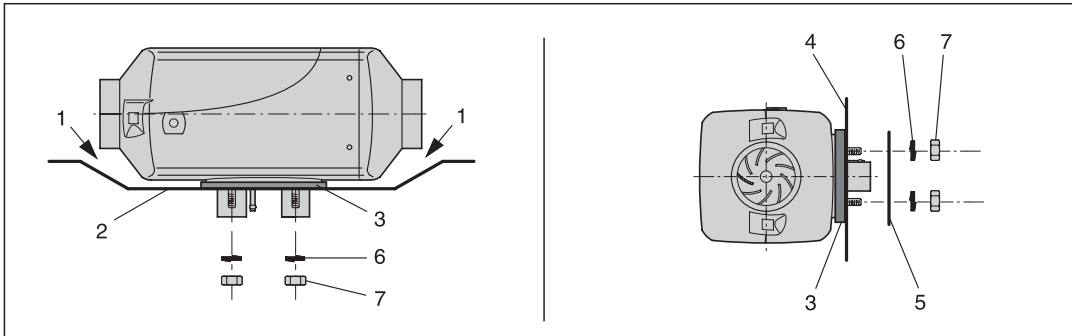

## Fastening the heater horizontally to the vehicle wall

1. There must be sufficient clearance between the heater and the vehicle floor – also check that the fan wheel runs freely.
2. The mounting surface must be flat and smooth.
3. The angle seal must be mounted.

4. The vehicle wall must be flat and smooth.
5. Reinforcement plate (if required, for Order No. see above)
6. Spring washer
7. Hexagon nut M6 (torque 5+1 Nm)

# AUXILIARY HEATER

## Airtronic/Airtronic M

### Heater air system

The parts for the hot air system are included in the scope of supply of the „Universal“ and „Plus“ installation kits. The „Plus“ installation kit does not contain any flexible pipes, these must be ordered separately. Refer to the product information for the Order No.



### **DANGER!**

### Risk of burning and injuries!

- The hoses of the heater air system and the hot air outlet are to be routed and fastened in such a way that they pose no temperature risk to people, animals or materials sensitive to temperature from radiation / contact or blowing directly. If necessary, a cover is to be fitted to the heater air system or hot air outlet.
- The outdoor hood must be fitted on the hot air outdoor side.
- A safety grid must be fitted to the heater air intake side and outdoor side if no air hoses are mounted, to prevent any injuries from the heater air fan or burns from the heat exchanger.
- High temperatures occur in the heater air system during and after the heater has been working. This is why it is important to avoid working in the vicinity of the heater air system while the heater is working. In such cases, switch the

heater off beforehand and wait until all parts have cooled down completely. If necessary, wear safety gloves.



### **Please note!**

- Installation of spherical reduction hood is not permitted in the Airtronic D4 Plus.
- The regulations and safety instructions to be observed for this chapter are on page 4 – 7.
- If air duct parts are connected the heater code number in “Using Universal Installation Kits”, page 8 and “Using Plus Installation Kits”, page 10 must be observed.



### **CAUTION!**

- The heater air intake openings must be arranged in such a way that under normal circumstances, it is not possible for exhaust from the vehicle engine and heater to be sucked into the system, or for the heating air to be contaminated with dust, salt spray, etc.
- For circulating air, position the circulating air intake in such a way that the outgoing hot air cannot be directly sucked in again.
- In the event of possible overheating, it is possible for local hot air temperatures of up to max. 150 °C or surface temperatures of up to max. 90 °C

to occur immediately before the defect shutdown. Therefore only temperature-resistant hot air hoses approved by us must be used for the heater air system!

- When checking the functions, the maximum outdoor temperature measured after the heater has been running about 10 minutes at approx. 30 cm from the outlet should not exceed 110 °C (at an intake temperature of approx. 20 °C).
- If there is a risk of the driver and passengers touching the heater when the vehicle is being driven normally, a contact protection device must be fitted.



# AUXILIARY HEATER

## Airtronic/Airtronic M

### Hot air system (example)

Some of the parts for the hot air system are included in the scope of supply of the universal installation kit, see page 8.

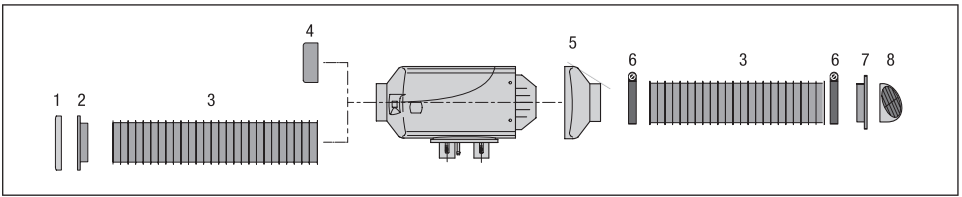

- 1. Safety grille
- 2. Connection sockets, intake side
- 3. Flexible tubing
- 4. Safety grille
- 5. Out ow hood
- 6. Hose clip
- 7. Connection sockets, discharge side
- 8. Air outlet, rotatable

**⚠ Please note!**

Observe the regulations and safety instructions for this chapter, given on page 4 to 7. When connecting air system parts, note the heater rating, see page 10. For important information on the air system, the heater guide numbers and the guide numbers for the air system parts, refer to the “Product information” document.

# AUXILIARY HEATER

## Airtronic/Airtronic M

### Installation of pipe connection sockets and air outlets

#### Cutting out the opening for the connection sockets

Use a keyhole saw to cut out an opening for the connection socket at the planned place of installation (vehicle floor or wall).

- Pipe connection socket  $\varnothing$  60 mm – keyhole saw  $\varnothing$  68 mm
- Pipe connection socket  $\varnothing$  75 mm /  $\varnothing$  90 mm – keyhole saw  $\varnothing$  92 mm

#### Fixing the pipe connection socket

Insert the pipe connection socket in the drillhole. Mark and drill three fixing holes  $\varnothing$  2 mm.

Use 3 pan-head tapping screws (3.9 x 13) to EN ISO 7049 to fix the connection sockets. Torque max.  $1 \pm 0.5$  Nm.



#### Please note!

Use pan-head screws only to install the connection socket, do not use countersunk head screws.

### Fix air outlet onto the pipe connection socket

Clip the corresponding air outlet onto the pipe connection socket.

### Installing flexible tubing on the pipe connection socket

Turn or latch the flexible tubing onto the thread of the pipe connection socket. It is not necessary to use a hose clip to fix the tubing onto the pipe connection socket.



#### Please note!

- In case of critical installation conditions, we recommend securing the flexible tubing with an additional hose clip at the pipe connection socket.
- Plastic sheathed hot air hoses with wire inlay must be fixed onto the pipe connection socket with a hose clip.
- Tightening torque for hose clip = 3 Nm.

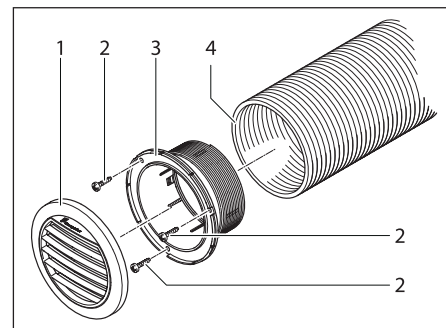

1. Air outlet
2. Self-tapping screw 3.9 x 13, EN ISO 7049
3. Pipe connection socket
4. Flexible tubing

### Installing the air blocking element



#### CAUTION!

#### Risk of overheating!

Blocking the hot air can cause overheating of the heater; the heater is switched off by the protection against overheating.

- The air blocking element may only be used in multi-duct air systems.

# AUXILIARY HEATER

## Airtronic/Airtronic M

The air blocking element is clipped into the pipe connection socket, discharge side. This reduces the cross-section of the pipe connection socket and reduces the quantity of air flow.

The air blocking element consists of two rings; the inner ring can be broken out. 1 ring = low degree of air blocking / 2 rings = high degree of air blocking

The air blocking element is available in sizes  $\varnothing 75$  mm and  $\varnothing 90$  mm (Order No. see product information).

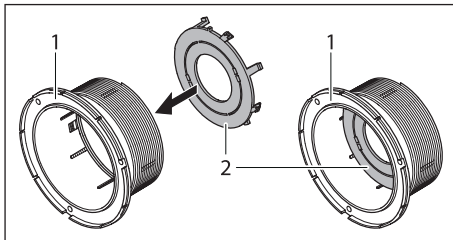

1. Connection sockets, discharge side
2. Air blocking element

## Exhaust system

### Mounting the exhaust system

The "Universal" and "Plus" installation kits include a flexible exhaust pipe, inner  $\varnothing 24$  mm, 1000 mm long and an exhaust silencer. The flexible exhaust pipe can be shortened to 20 cm or lengthened to max. 2 m, depending on the installation conditions. Fasten the exhaust silencer to a suitable position in the vehicle. Use a pipe clip to fix a short exhaust pipe end (with end sleeve) to the exhaust silencer (Anzugsdrehmoment 7+0.5 Nm). Use a pipe clip (tightening torque 7+0.5 Nm) to fix a short exhaust end pipe (with end sleeve) to the exhaust silencer.



### CAUTION!

### Safety instructions!

The whole exhaust system gets very hot during and immediately after the heater has been working. This is the reason why the exhaust system must be installed according to these instructions.

- The exhaust outlet must end in the open air.
- The exhaust pipe must not protrude beyond the lateral limits of the vehicle.

- Install the exhaust pipe sloping slightly downwards. If necessary, make a drain hole approx.  $\varnothing 5$  mm at the lowest point to drain off condensation.
- Important functional parts of the vehicle must not be impaired (keep sufficient clearance).
- Mount the exhaust pipe with sufficient clearance to heat-sensitive parts. Pay particular attention to fuel pipes (plastic or metal), electrical cables and brake hoses etc.!
- Exhaust pipes must be fastened safely (recommended clearance of 50 cm) to avoid damage from vibrations.
- Route the exhaust system so that the emitted fumes are not sucked in with the combustion air.
- The mouth of the exhaust pipe must not get clogged by dirt and snow.
- The mouth of the exhaust pipe must not point in the direction of travel.
- Always fasten the exhaust silencer to the vehicle.

# AUXILIARY HEATER

## Airtronic/Airtronic M



### **DANGER!**

#### **Risk of injuries and burns!**

Every type of combustion produces high temperatures and toxic exhaust fumes. This is the reason why the exhaust system must be installed according to these instructions.

- Do not perform any work on the exhaust system while the heater is working.
- Before working on the exhaust system, first switch the heater off and wait until all parts have cooled down completely, wear safety gloves if necessary.
- Do not inhale exhaust fumes.



### **Please note!**

- Comply with the regulations and safety instructions for this chapter on page 4 – 7.
- If a silencer is fitted, the exhaust end pipe must be much shorter than the flexible exhaust pipe between the heater and the exhaust silencer.
- Small arrows indicating the direction of flow have been cast into the fittings to differentiate between the combustion air and the exhaust fittings at the heater (see diagram page 23).
- To prevent contact erosion, the clips used to fix the exhaust pipe must be made of stainless steel. The order No.

for the stainless steel fixing clips is given in the product information.

#### **Combustion air system**

##### **Mounting the combustion air system**

The universal installation kit includes a flexible combustion air hose, inner Ø 25 mm, 1000 mm long.

If necessary the flexible combustion air hose can be shortened to 20 cm or lengthened to max. 2 m depending on the installation conditions.

Use a pipe clip (tightening torque 3+0.5 Nm) to fix the flexible combustion air hose to the heater and use hose clips or cable ties to fix in suitable positions.

Fit an end sleeve after completing the installation.

The „Plus“ installation kit includes a combustion air intake silencer with a flexible connection hose (inner diameter 25 mm). Use a pipe clip (tightening torque 3+0.5 Nm) to fix the flexible connection hose to the heater and use hose clips or cable ties to fix in suitable positions. Fit an end sleeve after completing the installation.



### **CAUTION!**

Safety instructions for the combustion air system!

- The combustion air opening must be free at all times.
- Position the combustion air intake to be sure that exhaust fumes cannot be sucked in with the combustion air.
- Do not arrange the combustion air intake to point against the wind blast.
- The combustion air intake must not get clogged with dirt and snow.
- Install the combustion air intake system sloping slightly downwards. If necessary, make a drain hole approx. Ø 5 mm at the lowest point to drain off condensation.



### **Please note!**

- For Airtronic and Airtronic M heaters a combustion air intake silencer can be fitted instead of the combustion air hose to reduce the noise level. Order No. see spare parts list or product information.
- Comply with the regulations and safety instructions for this chapter on page 4 – 7.

# AUXILIARY HEATER

Airtronic/Airtronic M

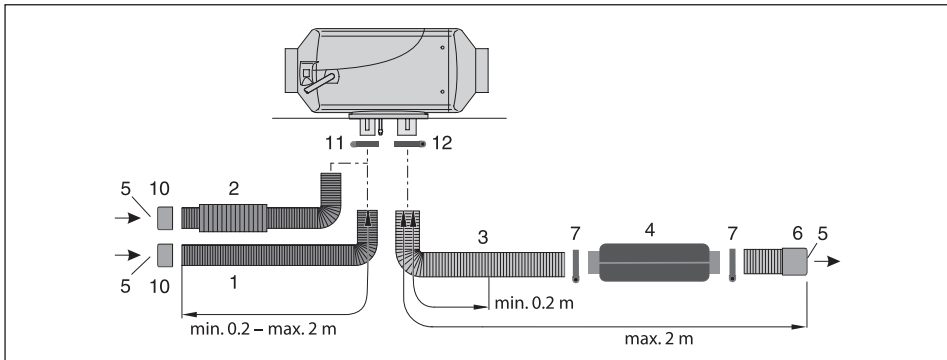

- 1 Combustion air hose, di = 25 mm
- 2 Combustion air silencer,  
– Included in the “Plus” installation kit
- 3 Exhaust pipe, di = 24 mm
- 4 Exhaust silencer
- 5 Intake / outlet opening – protect from wind, snow, dirt and water.
- 6 End sleeve, combustion air
- 7 End sleeve, exhaust
- 8 Combustion air connection
- 9 Exhaust connection
- 10 End sleeve, combustion air
- 11 Hose clip
- 12 Exhaust hose clip

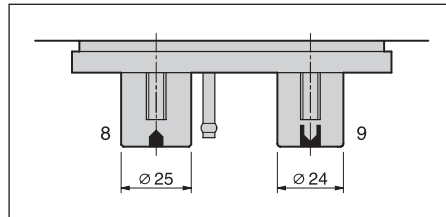

# AUXILIARY HEATER

## Airtronic/Airtronic M

### Fuel supply

#### Mounting the dosing pump, routing the fuel pipes and mounting the fuel tank

The following safety instructions must be observed when mounting the dosing pump, routing the fuel pipes and mounting the fuel tank.

Deviations from the instructions stated here are not allowed. Failure to comply can result in malfunctions.



**DANGER!**

#### Risk of re, explosion, poisoning and injuries!

Caution when handling fuel.

- Switch off the vehicle engine and heater before refuelling and before working on the fuel supply.
- No naked lights when handling fuel.
- Do not smoke.
- Do not inhale fuel vapours.
- Avoid any contact with the skin.



**CAUTION!**

#### Safety instructions for routing the fuel pipes!

- Only use a sharp knife to cut off fuel hoses and pipes. Interfaces must not be crushed and must be free of burrs.
- The fuel pipe from the dosing pump to the heater should be routed at a continuous rise.
- Fuel pipes must be fastened safely to avoid any damage and / or noise production from vibrations (recommended clearance of approx. 50 cm).
- Fuel pipes must be protected from any mechanical damage.
- Route the fuel pipes so that any distortion of the vehicle, engine movements etc. can not have any lasting effect on the service life.
- Use hose clips to secure all hose connections in the fuel supply (tightening torque 1+0.2 Nm).
- Parts carrying fuel must be protected from interfering heat.
- Never route or fasten the fuel pipes to the heater or vehicle exhaust system. At crossings, always ensure adequate heat clearance, if necessary attach

heat deflection plates or protective hose (For Order No. of protective hose, see product information).

- Dripping or evaporating fuel must never be allowed to collect on hot parts or ignite on electric systems.
- When connecting fuel pipes with a fuel hose, always mount the fuel pipes in a butt joint to prevent any bubbles from forming.

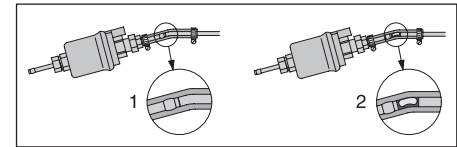

1 Correct connection

2 Incorrect connection – bubble formation

#### Safety instructions for fuel pipes and fuel tanks in buses and coaches

- In buses and coaches, fuel pipes and fuel tanks must not be routed through the passenger compartment or driver's cab.
- Fuel tanks in buses and coaches must be positioned in such a way that the exits are not in direct danger from a possible fire.

# AUXILIARY HEATER

Airtronic/Airtronic M



## Please note!

- Comply with the regulations and safety instructions for this chapter on page 4 – 7.
- For noise reasons, do not rigidly t fuel pipes onto structural sound transferring components.  
A sponge rubber hose can be pushed over the fuel tubes for noise reduction.

# AUXILIARY HEATER

## Airtronic/Airtronic M

### Fuel supply

Fuel feed point with T-piece from the fuel return line from the tank tting to the vehicle engine

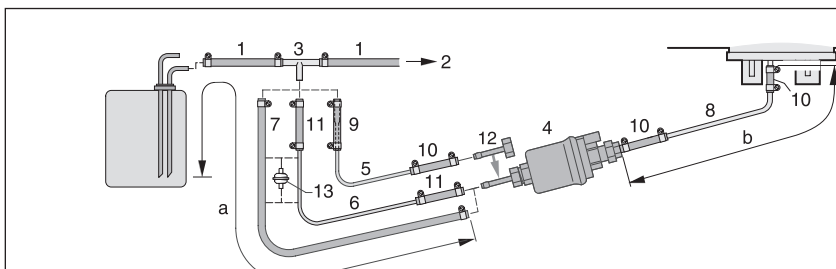

1. Fuel return line, vehicle tank
2. To the vehicle's engine, mechanical fuel or injection pump
3. T-piece, 8-6-8 or 10-6-10
4. Dosing pump
5. Fuel pipe, 4 x 1 (di = Ø 2 mm)
6. Fuel pipe, 6 x 2 (di = Ø 2 mm)
7. Fuel hose, 5 x 3 (di = Ø 5 mm)
8. Fuel pipe, 4 x 1.25 (di = Ø 1,5 mm)
9. Adapter Ø 6 / 4
10. Fuel hose, 3,5 x 3 (di = Ø 3.5 mm), approx. 50 mm long
11. Fuel hose, 5 x 3 (di = Ø 5 mm), approx. 50 mm long

12. Pipe connectors, da = Ø 4 mm
13. Fuel filter - required for contaminated fuel only.

\*If necessary, a fuel pipe 4 x 1 (di = Ø 2 mm) can be used for diesel heaters instead of the fuel pipe 4 x 1.25 (di = Ø 1.5 mm), Item (8).  
The details regarding the pipe lengths remain unchanged. The fuel pipe, 4 x 1 must be order separately. Order No. see spare parts list or product information.

### Possible pipe lengths

#### Intake side

Airtronic  
a = max.  
5 m

Airtronic M  
a = max.  
2 m

#### Pressure side

Diesel heaters  

- For suction pipe di = Ø 2 mm, b = max. 6 m
- For suction pipe di = Ø 5 mm, b = max. 10 m

Petrol heater  

- b = max. 4 m



### Please note!

- Insert the T-piece (3) in the fuel return line upstream of the feed pump.
- Items (5), (9) and (12) are included in the „Plus“ installation kit only.
- Item (6) is included in the universal installation kit only.
- Items (7) and (13) must be ordered separately. The order no. is given in the product information.



# AUXILIARY HEATER

Airtronic/Airtronic M

## Installation position of the T-piece

Use the installation positions shown in the diagram when insert- ing a T-piece.

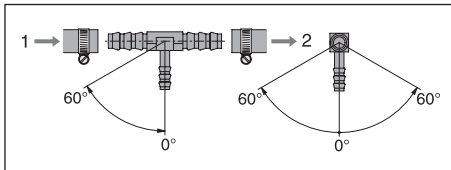

1. Direction of flow from the fuel tank
2. Direction of flow to the vehicle engine

# AUXILIARY HEATER

## Airtronic/Airtronic M

### Fuel supply

Fuel feed point with tank connection – ascending pipe, integrated in the vehicle tank or in the tank fitting

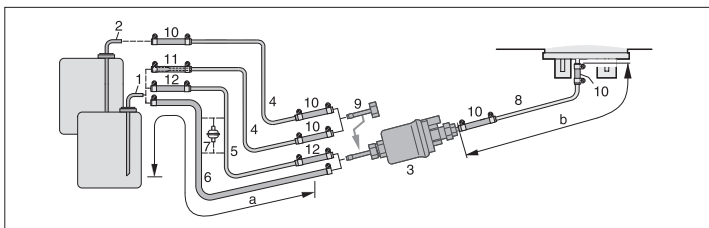

1. Tank connection for metal tank - di = Ø 2 mm, da = Ø 6 mm
2. Tank connection for tank fitting - di = Ø 2 mm, da = Ø 4 mm
3. Dosing pump
4. Fuel pipe, 4 x 1 (di = Ø 2 mm)
5. Fuel pipe, 6 x 2 (di = Ø 2 mm)
6. Fuel hose, 5 x 3 (di = Ø 5 mm)
7. Fuel filter - required for contaminated fuel only.
8. Fuel pipe, 4 x 1.25 (di = Ø 1,5 mm)
9. Pipe connectors, da = Ø 4 mm

10. Fuel hose, 3,5 x 3 (di = Ø 3.5 mm) approx. 50 mm long
11. Adapter Ø 6 / 4
12. Fuel hose, 5 x 3 (di = Ø 5 mm), approx. 50 mm long

If necessary, a fuel pipe 4 x 1 (di = Ø 2 mm) can be used for diesel heaters instead of the fuel pipe 4 x 1.25 (di = Ø 1.5 mm), Item (8).

The details regarding the pipe lengths remain unchanged. The fuel pipe, 4 x 1 must be order separately. Order No. see spare parts list or product information.

### Possible pipe lengths

#### Intake side

Airtronic  
a = max.  
5 m

Airtronic M  
a = max.  
2 m

#### Pressure side

Diesel heaters

- For suction pipe di = Ø 2 mm, b = max. 6 m
- For suction pipe di = Ø 5 mm, b = max. 10 m

Petrol heater

- b = max. 4 m



### Please note!

- Items (2), (4), (8), (9) and the connection parts are included in the "Tank Connection" kit, Order No. 22 1000 20 13 00 (The "Tank Connection" kit is included in the „Plus" installation kit).
- Item (5) is included in the universal installation kit only.
- Item (11) is included in the "Plus" installation kit only.
- Items (6) and (7) must be ordered separately. The order no. is given in the product information.
- When installing tank connection maintain a minimum distance of 50 ± 2 mm from the end of the riser pipe and the bottom of the tank.
- Consult the vehicle manufacturer before installing the tank connection in a metal tank.

# AUXILIARY HEATER

## Airtronic/Airtronic M



### CAUTION!

#### Safety instructions for the fuel supply!

- The fuel must not be conveyed by gravity or overpressure in the fuel tank.
- Withdrawal of fuel after the vehicle's fuel pump is not allowed.
- When the pressure in the fuel pipe is more than 0.2 bar to max. 4,0 bar, use a pressure reducer (order no. 22 1000 20 08 00) or separate tank connection.
- When the pressure in the fuel pipe is more than 4,0 bar or there is a non-return valve in the return pipe (in the tank), a separate tank connection must be used.
- When using a T-piece in a plastic pipe, always use support sleeves in the plastic. Connect the T-piece and the plastic pipe with corresponding fuel hoses and secure with hose clips.

#### Installation position of the dosing pump

Always mount the dosing pump with the pressure side rising upwards. Every installation position over 15° is allowed, although an installation position between 15° and 35° is preferable.

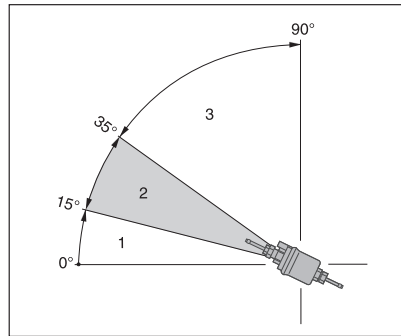

1. Installation position between 0° and 15° is not allowed.
2. Preferred installation position in range 15° to 35°.
3. Installation position in range 35° to 90° is allowed.

#### Possible suction and pressure height of the dosing pump

Pressure height from vehicle tank to dosing pump: a = max. 3000 mm  
Intake height in pressure-less vehicle tank:

- b = max. 1000 mm for diesel
- b = max. 1500 mm for petrol

Intake height in vehicle tanks with withdrawal by negative pressure (valve with 0.03 bar in tank cap):  
b = max. 400 mm

Pressure height of the dosing pump to the heater: c = max. 2000 mm

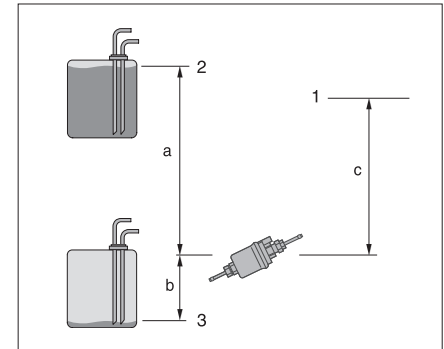

1. Connection to heater
2. Max. fuel level
3. Min. fuel level

# AUXILIARY HEATER

## Airtronic/Airtronic M

### Please note!

Check tank venting.

### CAUTION!

#### Safety instructions for installing the dosing pump

- Always mount the dosing pipe with the pressure side rising upwards – minimum incline 15°.
- Protect the dosing pump and filter from intolerable heat, do not mount near to the silencers and exhaust pipes.

### CAUTION!

#### Fuel supply safety information

It is not permitted to operate the heater with unapproved fuel / fuel mixtures or the addition of used oil.

Failure to comply with this can lead to personal injuries as well as a malfunction or damage to the heater.

Only the fuel approved by the manufacturer or by the vehicle manufacturer is to be used.

#### Fuel quality for petrol heaters

The heater runs without problems on normal commercial petrol according to DIN EN 228.

#### Fuel quality for diesel heaters

- The heater runs without problems on normal commercial diesel fuel according to DIN EN 590.
- During the winter months the diesel fuel is adapted to low temperatures from 0 °C to –20 °C. Problems can therefore only arise if outdoor temperatures are extremely low - which also applies to the vehicle's engine - please refer to the vehicle manufacturer's regulations.
- In special cases and at outdoor temperatures above 0 °C the heater can also be run on heating oil EL according to DIN 51603.
- If the heater is run from a separate tank, please comply with the following rules:
  - if outdoor temperatures over 0 °C, Use diesel fuel according to DIN EN 590.
  - if outdoor temperatures from 0 °C to 20 °C, Use winter diesel fuel according to DIN 590.
  - if outdoor temperatures –20 °C to –40 °C, Use Arctic Diesel or Polar Diesel.

### Please note!

After refuelling with winter or cold diesel, the fuel pipes and the metering pump must be filled with the new fuel by letting the heater run for 15 min!

#### Operation with biodiesel (FAME)

#### Airtronic

The heater is not approved for operation with bio diesel fuel (FAME). Up to 10 % bio diesel fuel (FAME) may be added.

#### Airtronic M

The diesel heater is approved for operation with bio diesel fuel (FAME) according to DIN EN 14 214.

### Please note!

- Bio diesel fuel (FAME) according to DIN EN 14 214
  - during the winter months is adapted to low temperatures from 0 °C to –20 °C.
  - The Flowability reduces at temperatures below 0 °C.
- When using 100 % bio diesel, the heater should be operated twice a year with diesel fuel (in the middle and at the end of a heating period) in order to burn off any possible biodiesel residues deposited.
- To do so, let the vehicle tank run almost empty and then fill with diesel fuel. While running on this tank filling, switch the heater on 2 to 3 times for 30 minutes at a time at the highest temperature setting.
- When operating with diesel / bio diesel mixtures of up to 50 % bio diesel, intermediate operation with pure diesel fuel is not necessary.

# AUXILIARY HEATER

## Airtronic/Airtronic M

### Operating instructions

The heater is operated by a control element.

Detailed operating instructions are enclosed with the control unit.

#### Please note!

The workshop / garage installing the heater will issue you with the operating instructions.

### Important instructions for operation Safety checks before the start

After a lengthy period of non-use (summer months) check that all parts fit securely (tighten screws where necessary).

Check the fuel system visually for any leaks.

### Heating at high altitudes

- up to 1500 m altitude, heating mode is possible without altitude adjustment.
- from 1500 m – 3000 m, heating mode for short stays (e.g. if crossing a pass or stopping for a break) is possible without adjusting the heater altitude.

#### Please note!

In case of a lengthy stay, e.g. winter camping, it is necessary to adjust the heater's altitude.

The heater's altitude is adjusted by installing an air pressure sensor; this is included in the altitude kit – Order No. 22 1000 33 22 00.

### Initial commissioning

The following points are to be checked by the company installing the heater during initial commissioning.

- After installation of the heater, the coolant circuit and the whole fuel supply system must be vented carefully. Comply with the instructions issued by the vehicle manufacturer.
- During the trial run of the heater, check all water and fuel connections for leaks and rattling.
- If the heater shows a fault during operation, find and eliminate the cause of the fault using a diagnosis unit.

#### Please note!

During the initial start-up of the heater, odours can be produced for a short time. This is fully normal during the first few minutes of operation and does not indicate a malfunction in the heater.

### Description of functions

#### Switching on

When the heater is switched on, the control lamp in the control element lights up.

The glow plug is switched on and the fan starts at low speed.

#### Please note!

If there is still too much residual heat in the heat exchanger from when the heater was last used, firstly only the fan starts up (cold blowing).

Once the residual heat has been cleared, the heater starts.

# AUXILIARY HEATER

## Airtronic/Airtronic M

### Starting Airtronic

After approx. 65 seconds the fuel supply starts and the fuel / air mixture in the combustion chamber ignites.

Once the combined sensor ( flame sensor) has detected the flame, the glow plug is switched off after 60 seconds. The heater is now in standard operation.

### Starting Airtronic M

After approx. 60 seconds the fuel supply starts and the fuel / air mixture in the combustion chamber ignites.

After the flame sensor has detected the flame, the glow plug is switched off after approx. 90 sec. The heater is now in standard operation.

After another 120 seconds, the heater has reached the "POWER" stage (maximum fuel quantity, maximum fan speed).

### Temperature selection with the control element

The control can be used to preselect an interior temperature. The resulting temperature can be within the range of +10 °C to +30 °C and depends on the selected heater, on the size of the space to be heated and on the prevailing outdoor temperature. The setting to be selected at

the control is an empirical value.

### Control in the heating mode

During the heating mode, the room temperature or the temperature of the sucked in heating air is constantly measured.

If the temperature is higher than the temperature selected on the control element, the heater starts to regulate its output. There are 4 control stages so that the amount of heat produced by the heater can be adjusted to the heating requirements. Fan speed and fuel quantity correspond to the particular control stage.

If the set temperature is still exceeded in the smallest control stage, the heater goes to the "OFF" stage with the fan running on for approx. 4 minutes to cool off. Then the fan continues at minimum speed (circulation mode) or is switched off (fresh air mode) until the heater is started again.

### Ventilating mode

In the ventilating mode, first the changeover switch "heating / venting" has to be activated and then the heater is switched on.

### Switching off

When the heater is switched off, the control lamp goes off and the fuel supply is switched off.

The fan runs on for approx. 4 minutes to cool down.

While the fan is running on, the glow plug is switched on for approx. 40 seconds to clean.

Special case:

If no fuel has been supplied or if the heater is in the "OFF" stage until it is switched off, the heater is stopped without any after running.

# AUXILIARY HEATER

## Airtronic/Airtronic M

### Control and safety devices

- If the heater does not ignite within 90 seconds after starting the fuel pump, the start is repeated. If the heater still does not ignite after another 90 seconds of pumping fuel, the heater is switched off, i.e. the fuel supply is off and the fan runs on for approx. 4 minutes.
- If the flame goes out by itself during operation, the heater is restarted. If the heater does not ignite within 90 seconds after the fuel pump has started, or ignites and goes off again within 15 minutes, the heater is switched off, i.e. the fuel supply is off and the fan runs on for approx. 4 minutes. This status can be remedied by briefly switching off and on again. Do not repeat the switching off/on routine more than twice.
- In the case of overheating, the combined sensor ( flame sensor / overheating sensor) triggers, the fuel supply is interrupted and the heater switched off. Once the cause of the overheating has been eliminated, the heater can be re-started by switching off and on again.
- If the lower or upper voltage limit is reached, the heater is switched off after 20 seconds.
- The heater does not start up when the glow plug is defect or when the electric lead to the dosing pump is interrupted.
- If the combined sensor ( flame sensor / overheating sensor) is defect or the electric lead interrupted, the heater starts up and is then switched off again

during the start phase.

- The speed of the fan motor is monitored continuously. If the fan motor does not start up or if the speed deviates by more than 10%, the heater is switched off after 30 sec.
- When the heater is switched off, the glow plug is switched on for 40 seconds (after-glowing) while the fan runs on to clean off any combustion residues.



### Please note!

Do not switch the heater off and on again more than twice.

### Forced shutdown in ADR mode (only for diesel heaters 24 volt)

In vehicles for the transport of dangerous goods (e.g. tanker trucks), the heater must be switched off before the truck drives into a danger area (refinery, fuel service station, etc.).

Failure to comply results in the heater switching off automatically when:

- The vehicle engine is switched off.
  - An additional unit is started up (e.g. auxiliary drive for unloading pump etc.).
- The fan then runs on for max. 40 seconds.

### Emergency shutdown – EMERGENCY OFF

If an emergency shutdown – EMERGENCY OFF – is necessary during operation, proceed as follows:

- Switch the heater off with the control or
- pull the fuse out or
- disconnect the heater from the battery.

# AUXILIARY HEATER

## Airtronic/Airtronic M

### Heater wiring

The electronic control box is integrated in the heater, which considerably simplifies the wiring required during installation.



### CAUTION!

### Safety instructions for wiring the heater!

The heater is to be connected up electrically according to the EMC directives.

EMC can be affected if the heater is not connected up correctly. For this reason, comply with the following instructions:

- Ensure that the insulation of electrical cables is not damaged. Avoid: chafing, kinking, jamming or exposure to heat.
- In waterproof connectors, seal any connector chambers not in use with filler plugs to ensure they are dirt-proof and water-proof.
- Electrical connections and ground connections must be free of corrosion and firmly connected.
- Lubricate connections and ground connections outside the heater interior with contact grease.



### Please note!

- Comply with the following when wiring the heater and the control element:
- With the appropriate electrical wiring, the heater fulfils the ADR regulations; please refer to the circuit diagrams at the end of this document.
- Electrical leads, switchgear and controllers must be arranged in the vehicle so that they can function perfectly under normal operating conditions (e.g. heat exposure, moisture etc.).
- The following cable cross sections are to be used between the battery and heater. This ensures that the max. tolerable voltage loss in the cables does not exceed 0.5 V for 12 V or 1 V for 24 V rated voltage.
- Cable cross sections for a cable length of (plus cable + minus cable):
  - up to 5 m = cable cross section 4 mm<sup>2</sup>
  - from 5 to 8 m = cable cross section 6 mm<sup>2</sup>
- If the plus cable is to be connected to the fuse box (e.g. terminal 30), the vehicle cable from the battery to the fuse box must be included in rating the overall cable length and possibly re-dimensioned if necessary.
- Insulate unused cable ends.



# AUXILIARY HEATER

## Airtronic/Airtronic M

### Parts list for the circuit diagrams Airtronic / Airtronic M and Airtronic / Airtronic M – ADR mode

-A1	Airtronic / Airtronic M control box
-A30	Fuse holder, 3 pin
-B1	Control sensor, internal
-B6	Flame and overheating sensor
-F1	Fuse 12 V = 20 A / 24 V = 10 A
-M4	Burner motor
-R1	Glow plug
-Y1	Fuel metering pump

#### Optional

b	Activation of vehicle blower and / or separate fresh air fan
---	--------------------------------------------------------------

#### Please note!

- The plus signal is only applied in „Low“ control stage (PIN 16, plus signal for relay, I<sub>max</sub> = 200 mA)

#### ADR function

Wiring for ADR mode (dangerous goods in utility or commercial vehicles, e.g. fuel tanker) - wire yourself according to vehicle circumstances

m	Battery isolating switch
n	Generator D+
o	Auxiliary drive NA+

#### Please note!

- It must be ensured that if the battery isolating switch is pressed due to EMERGENCY STOP, all the heater's electric circuits are disconnected from the battery immediately (without any consideration of the heater's status).
- If the battery isolating switch is pressed to disconnect the battery from all electric circuits, the heater must be switched off first and if applicable you must wait until the heater's after-run has finished.

a to the heater

b to the control unit

x Insulate and tie back any cable ends that are not needed.

#### Please note!

Circuit diagram for Airtronic / Airtronic M see Page 34 and 35. Circuit diagram for Airtronic / Airtronic M in ADR mode - see also Page 36.

For circuit diagrams for other control units, e.g. EasyStart T, R and R+, refer to the installation instructions of the control unit concerned.

# AUXILIARY HEATER

## Airtronic/Airtronic M

### Airtronic / Airtronic M

X.15C \_\_\_\_\_  
 Ign (+)  
 X.58C \_\_\_\_\_  
 Light (+)  
 X.30C \_\_\_\_\_  
 Bat (+)  
 X.31C \_\_\_\_\_  
 Bat (-)

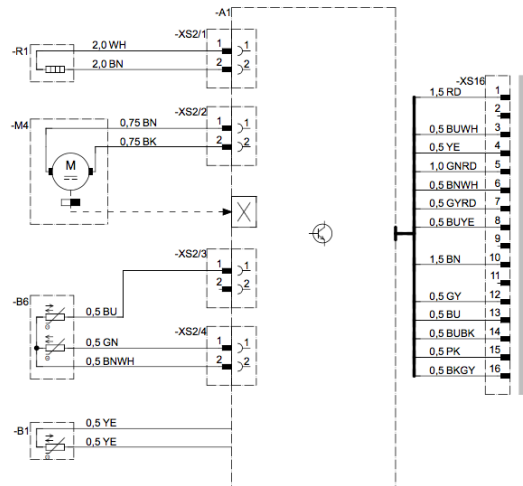

# AUXILIARY HEATER

Airtronic/Airtronic M

Airtronic / Airtronic M

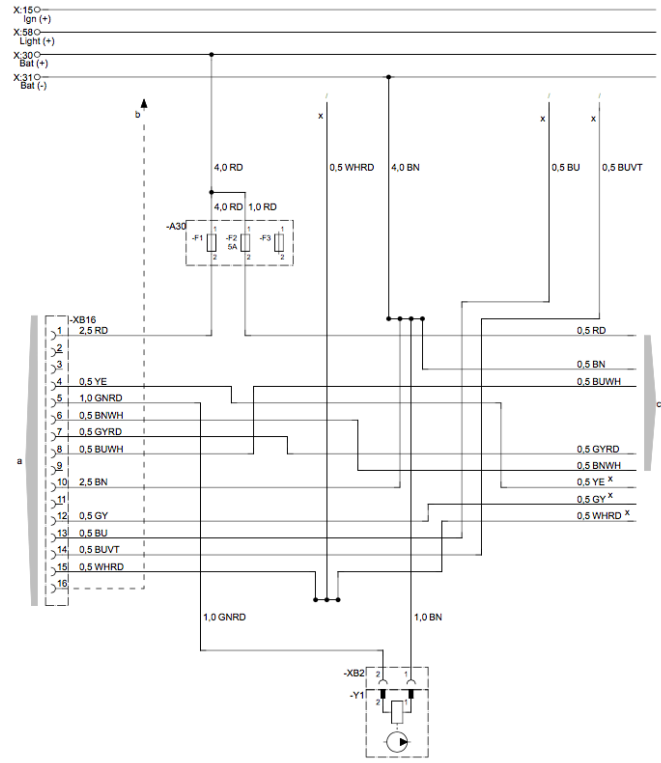

# AUXILIARY HEATER

## Airtronic/Airtronic M

### Circuit diagram Airtronic / Airtronic M – ADR mode

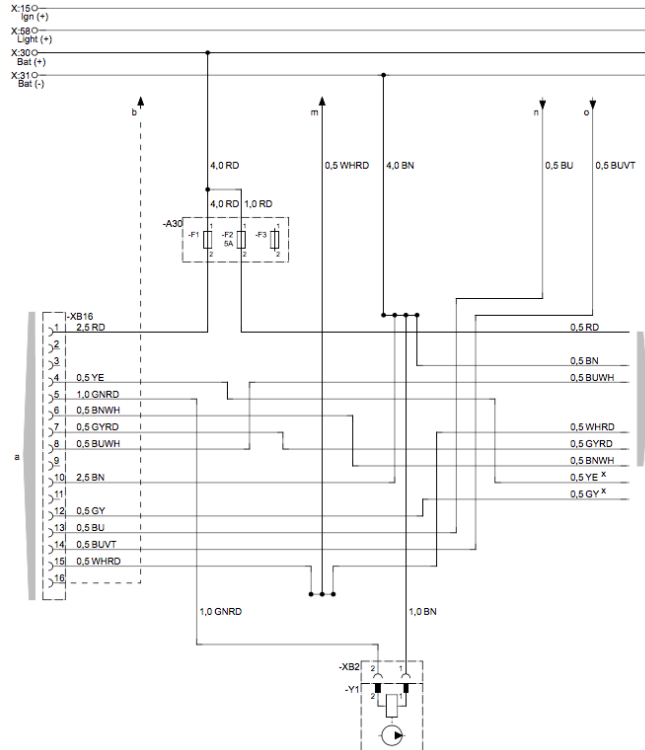

25.2069.0089.04.0A

# AUXILIARY HEATER

Airtronic/Airtronic M

## Circuit diagram EasyStart Timer

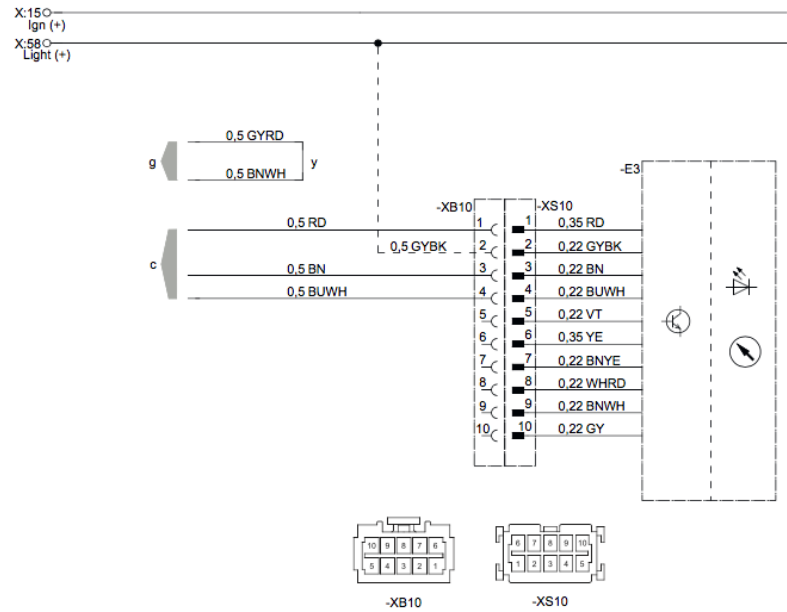

### Cable colours

- RD = red
- BU = blue
- WH = white
- GY = grey
- VT = violet
- BK = black
- GN = green
- BN = brown
- YE = yellow

**Please note!**

- For heater circuit diagrams see page 34, 35 and 36.
- Further circuit diagrams for the EasyStart Timer are printed in the Installation Instructions Plus, these are available to view and download from the Service Portal.

E3 EasyStart Timer  
 c to the heater  
 g to the heater  
 y Connect cables and insulate

22 1000 34 97 20

# AUXILIARY HEATER

## Airtronic/Airtronic M

### Circuit diagram EasyStart Remote+

X:15C  
Ign (+)

X:58C  
Light (+)

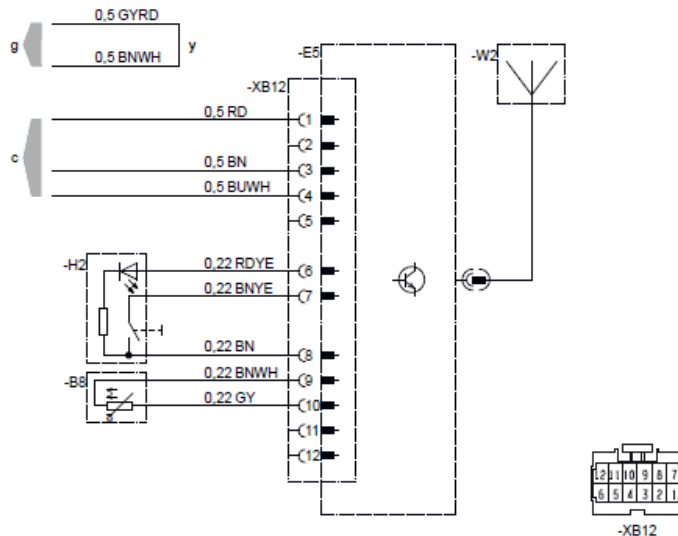

25 2361 00 97 01 C

- B8 Room temperature sensor
- E5 EasyStart Remote+ radio remote control
- H2 Button
- W2 Antenna
- c to the heater
- g to the heater
- y Connect cables and insulate

### Cable colours

- RD = red
- BU = blue
- WH = white
- GY = grey
- VT = violet
- BK = black
- GN = green
- BN = brown
- YE = yellow

### **Please note!**

- For heater circuit diagrams see page 34 and 35.
- Further circuit diagrams for the EasyStart Remote+ are printed in the Installation Instructions Plus, these are available to view and download from the Service Portal.

# AUXILIARY HEATER

Airtronic/Airtronic M

## Circuit diagram EasyStart Select

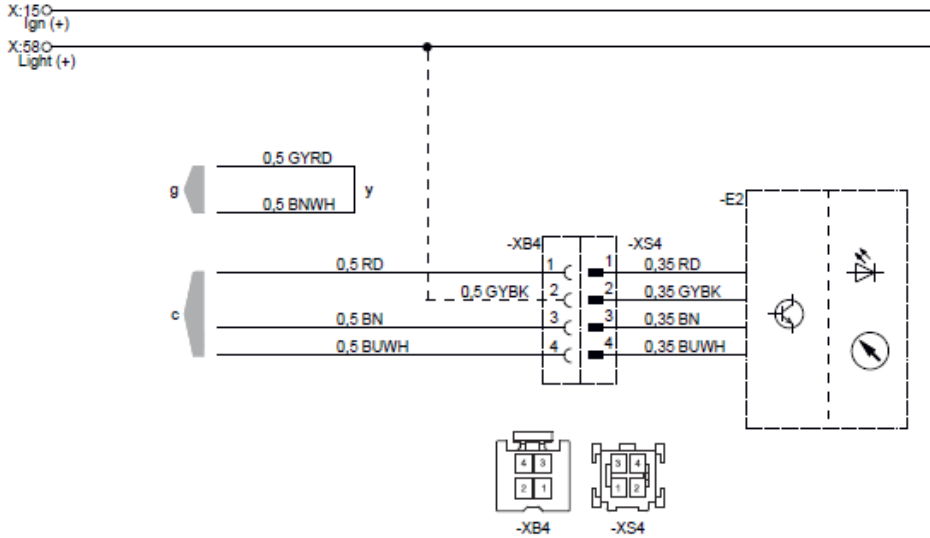

E2 EasyStart Select  
 c to the heater  
 g to the heater  
 y Connect cables and insulate

### Cable colours

RD = red                      VT = violet  
 BU = blue                    BK = black  
 WH = white                 GN = green  
 GY = grey                    BN = brown  
 YE = yellow

**Please note!**

- For heater circuit diagrams see page 34 and 35.
- Further circuit diagrams for the EasyStart Select are printed in the Installation Instructions Plus, these are available to view and download from the Service Portal.

25 2361 00 97 05 B

# AUXILIARY HEATER

## Airtronic/Airtronic M

### Circuit diagram EasyStart Call

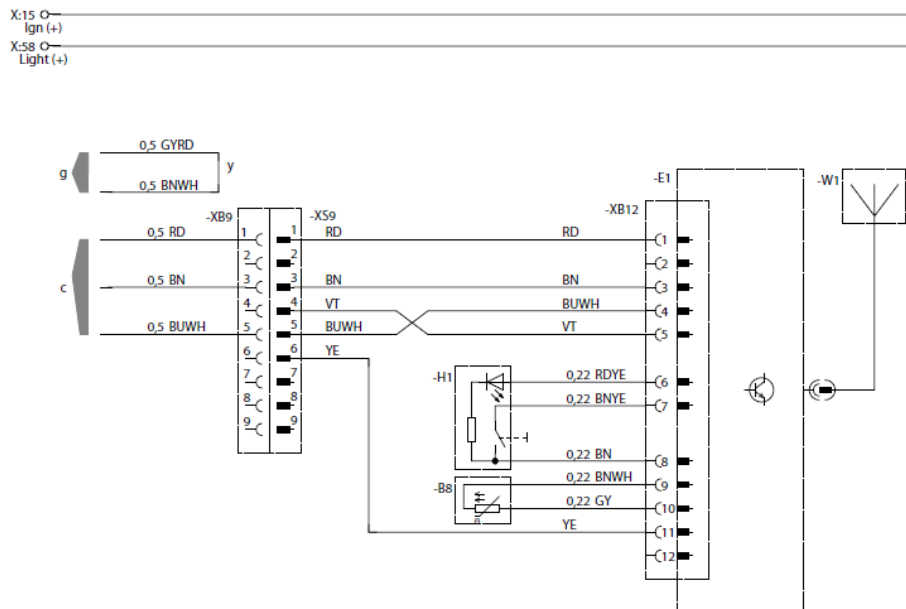

25 2361 00 97 02 B

- B8 Room temperature sensor
- E1 EasyStart Call radio remote control
- H1 EasyStart Call button
- W1 EasyStart Call antenna
- c to the heater
- g to the heater
- y Connect cables and insulate

### Cable colours

- RD = red
- BU = blue
- WH = white
- GY = grey
- YE = yellow
- VT = violet
- BK = black
- GN = green
- BN = brown

### **Please note!**

- For heater circuit diagrams see page 34 and 35.
- Further circuit diagrams for the EasyStart Call are printed in the Installation Instructions Plus, these are available to view and download from the Service Portal.



# AUXILIARY HEATER

Airtronic/Airtronic M

## In case of faults, please check the following points

- If the heater does not start after being switched on:
  - Switch the heater off and on again.
- If the heater still does not start, check whether:
  - There is fuel in the tank?
  - The fuses are OK?
  - The electrical cables, connections etc. are OK?
  - Anything is clogging the combustion air supply or exhaust system?

## Troubleshooting

If the heater remains faulty even after these points have been checked, or another malfunction occurs in your heater, please contact:

- For installation ex works, your contract workshop.
- For subsequent installation, the workshop who installed your heater.



### Please note!

Please note that warranty claims can be become void if the heater is changed by a third party or by this installation of third parts.

## Maintenance instructions

- Switch the heater on once a month for about 10 minutes, even outside the heating period.
- Before the heating period starts, the heater should undergo a trial run. If persistent extreme smoke develops, unusual burning noises or a clear fuel smell can be perceived or if electric / electronic parts heat up, the heater must be switched off and put out of service by removing the fuse. In this case, the heater should not be started up again until it has been checked by qualified staff who have been trained on Eberspächer heaters.
- Check the openings of the combustion air supply and exhaust system after longer standstill periods, clean if necessary!

## Service

## Technical Support

If you have any technical questions or problems with the heater, the control unit or the operating software, please contact the following service address:  
Please note! support-UK@eberspaecher.com

# AUXILIARY HEATER

## Airtronic/Airtronic M

### Certification

The high quality of Eberspächer's products is the key to our success.

To guarantee this quality, we have organised all work processes in the company along the lines of quality management (QM).

Even so, we still pursue a large number of activities for continuous improvement of product quality in order to keep pace with the similarly constantly growing requirements made by our customers. All the steps necessary for quality assurance are stipulated in international standards.

This quality is to be considered in a total sense.

It affects products, procedures and customer / supplier relationships. Officially approved public experts assess the system and the corresponding certification company awards a certificate.

Eberspächer Climate Control Systems GmbH has already qualified for the following standards:

**Quality management as per ISO TS 9001:2015 and IATF 16949:2016**  
**Environment management system as per ISO 14001:2015**

### Disposal

#### Disposal of materials

Old devices, defect components and packaging material can all be separated and sorted into pure-grade fractions so that all parts can be disposed of as required in an environment-friendly manner or recycled where applicable.

Electric motors, controllers and sensors (e.g. temperature sensors) are deemed to be "electronic scrap".

#### Dismantling the heater

The heater is dismantled according to the repair stages in the current troubleshooting / repair instructions.

#### Packaging

The packaging of the heater can be kept in case it has to be sent back.

### EU Declaration of Conformity

We herewith declare that the version of the heater placed on the market by us conforms to the applicable provisions of the following EU Directive.

EU Directive 2014/30/EU



The full Declaration of Conformity can be viewed and downloaded from the download centre under [www.eberspaecher.com](http://www.eberspaecher.com).

### UKCA Declaration of Conformity

We herewith declare that the version of the heater placed on the market by us conforms to the applicable provisions of the following EU Directive.

Electromagnetic Compatibility, Statutory Instrument 2016, No. 1091



The full Declaration of Conformity can be viewed and downloaded from the download centre under [www.eberspaecher.com](http://www.eberspaecher.com)

### List of abbreviations

#### **ADR**

European agreement about the international transport of dangerous goods on the road.

#### **ECE regulation**

Internationally agreed, uniform technical specifications for vehicles, parts and equipment of motor vehicles

#### **EMC directive**

Electromagnetic compatibility.

#### **JE partner**

Eberspächer partner.

#### **FAME**

Biodiesel according to DIN V 14 214.

#### **CE marking**

With the CE marking, the manufacturer declares in a declaration of conformity, that the version of the heater placed on the market conforms to the relevant provisions of the EU Directive.

# AUXILIARY HEATER

## Hydronic M-II

### Special text structure, presentation and picture symbols

This manual uses special text structures and picture symbols to emphasise different contents.

Please refer to the examples below for the corresponding meanings and associated actions.

Special structure and presentations

A dot (·) indicates a list which is started by a heading. If an indented dash (–) follows a dot, this list is subordinate to the dot.

### Picture symbols

#### **REGULATION!**

This picture symbol with the remark “Regulation” refers to a statutory regulation. Failure to comply with this regulation results in expiry of the type permit for the heater and preclusion of any guarantee and liability claims on J. Eberspächer GmbH & Co. KG.

#### **DANGER!**

This picture symbol with the remark “Danger!” refers to the risk of a fatal

danger to life and limb. Under certain circumstances, failure to comply with these instructions can result in severe or life-threatening injuries.

#### **CAUTION!**

This picture symbol with the remark “Caution!” refers to a dangerous situation for a person and/or the product. Failure to comply with these instructions can result in injuries to people and / or damage to machinery.

#### **Please note!**

These remarks contain application recommendations and useful tips for installation of the heater.

### Important information before starting work

#### Range of application of the heater

The water heater operating independently of an engine is intended for installation in the following vehicles, depending on its heating output:

- Vehicles of all kinds
- Construction machinery
- Agricultural machinery

- Boats, ships and yachts

#### **Please note!**

- Installation of the heater is permitted in vehicles used for the transport of dangerous goods as per ADR.
- The heater is not approved for installation in vehicle compartments used by persons (more than 8 passenger spaces) in Class M2 and M3 vehicles (vehicles for the transport of passengers / commercial buses).
- The heater is not approved for installation in the driver or passenger compartments of Class M1 vehicles (vehicles for the transport of passengers / cars) and Class N vehicles (vehicles for the transport of goods).

On account of its functional purpose, the heater is not permitted for the following applications:

- Long-term continuous operation, e.g. for pre-heating and heating of:
  - Residential rooms
  - Garages
  - Work huts, weekend homes and hunting huts
  - Houseboats, etc.

# AUXILIARY HEATER

## Hydronic M-II



### CAUTION!

#### Safety instructions for application and proper purpose

The heater must only be used and operated for the range of application stated by the manufacturer in compliance with the "Operating instructions" included with every heater.

#### Statutory regulations

The Federal Road Transport Directorate has issued an "EC type approval" and an "EMC type approval" for the heater for installation in motor vehicles and with the following official type approval marks, noted on the heater name plate.

Hydronic M-II

EG-00 0215

EMV-035075



### REGULATION!

#### Directive 2001 / 56 / EU of the European Parliament and the Council

- Arrangement of the heater
- Parts of the structure and other components near the heater must be

protected from excess heat exposure and possible contamination from fuel or oil.

- The heater must not pose a fire hazard even when it overheats. This requirement is deemed to be fulfilled when adequate clearance to all parts is observed during installation, sufficient ventilation is provided and fireproof materials or heat plates are used.
- The heater may not be mounted in the passenger compartment of Class M2 and M3 vehicles. A unit may however be used in a hermetically sealed housing which also corresponds to the conditions stated above.
- The factory nameplate or duplicate must be affixed so that it can still be easily read when the heater is installed in the vehicle.
- All appropriate precautions must be taken when arranging the heater to minimise the risk of injuries to persons or damage to other property.

#### • Fuel supply

- The fuel intake connection must not be located in the passenger compartment and must be sealed with a properly closing lid to prevent any fuel leaks.
- In heaters for liquid fuel where the

heater fuel is separate from the vehicle fuel, the type of fuel and intake connection must be clearly identified.

- A warning sign is to be fixed to the intake connection indicating that the heater must be switched off before refuelling.

#### • Exhaust system

- The exhaust outlet must be arranged so as to prevent any penetration of exhaust fumes into the vehicle interior through the ventilation system, warm air intakes or open windows.

#### • Combustion air intake

- The air for the heater combustion chamber must not be sucked in from the passenger compartment of the vehicle.
- The air intake must be arranged or protected in such a way that it cannot be blocked by other objects.
- Operating status display
- A clearly visible operating display in the user's field of vision must indicate when the heater is switched on and off.

# AUXILIARY HEATER

## Hydronic M-II

§

### REGULATION!

#### **Additional regulations for certain vehicles named in Directive 94 / 55 / EC (ADR Framework Directive)**

##### **Scope**

This appendix applies to vehicles for which the special provisions of Directive 94 / 55 / EC apply to combustion heaters and their installation.

##### **Definition of terms used**

For the purposes of this appendix, the vehicle designations „EX / II“, „EX / III“, „AT“, „FL“ and „OX“ according to Chapter 9.1 of Annex B of Directive 94 / 55 / EC are used.

##### **Technical regulations**

##### **General provisions (EX / II, EX / III, AT, FL and OX vehicles)**

##### **Avoid heating and ignition**

The combustion heaters and their exhaust gas routing shall be designed, located, protected or covered so as to prevent any unacceptable risk of heating or ignition of the load. This requirement shall be

considered as fulfilled if the fuel tank and the exhaust system of the appliance conform to provisions in 3.1.1.1 and 3.1.1.2.

Compliance with these regulations shall be checked in the complete vehicle.

##### **Fuel tanks**

Fuel tanks for supplying the heater shall conform to the following regulations:

- In the event of any leakage, the fuel shall drain to the ground without coming into contact with hot parts of the vehicle or the load;
- fuel tanks containing petrol shall be equipped with an effective flame trap at the filler opening or with a closure enabling the opening to be kept hermetically sealed.

##### **Exhaust system and exhaust pipe layout**

The exhaust system as well as the exhaust pipes shall laid out or protected to avoid any danger to the load through heating or ignition. Parts of the exhaust system situated directly below the fuel tank (diesel) shall have a clearance of at least 100 mm or be protected by a thermal shield.

##### **Switching on the combustion heater**

The combustion heater may only be switched on manually. Automatic switching on via a programmable switch is not permitted.

##### **EX / II and EX / III vehicles**

Combustion heaters for gaseous fuels are not permitted.

##### **FL vehicles**

Combustion heaters must be able to be taken out of service/disabled at least by the methods described in the following:

- a) Switching off manually in the driver's cabin
- b) Switching off the vehicle's engine; in this case the heater may be manually switched back on by the vehicle driver;
- c) Starting up of a feed pump installed in the vehicle for the dangerous goods carried.

##### **Combustion heater after-run**

After-running of the switched off combustion heater is permitted. In the cases named in the „FL vehicles“ paragraph under letters b) and c) the supply of combustion air must be interrupted by suitable means after a maximum after-run period of 40 seconds.

# AUXILIARY HEATER

## Hydronic M-II

Only combustion heaters whose heat exchangers are verifiably not damaged by the reduced after-run period of 40 seconds beyond their usual use period may be used.



### Please note!

- Compliance with the statutory regulations, the additional regulations and safety instructions is prerequisite for guarantee and liability claims. Failure to comply with the statutory regulations and safety instructions and incorrect repairs even when using original spare parts make the guarantee null and void and preclude any liability for J. Eberspächer GmbH & Co. KG.
- Subsequent installation of this heater must comply with these installation instructions.
- The statutory regulations are binding and must also be observed in countries which do not have any special regulations.
- When the heater is to be installed in vehicles not subject to the German Ordinance for the Registration of Motor Vehicles (StVZO), for example ships, the specially valid regulations and installation instructions for these special applications must be observed.
- Installation of the heater in special vehicles must comply with the

- regulations applying to such vehicles.
- Other installation requirements are contained in the corresponding sections of this manual.

### Safety instructions for installation and operation



### DANGER!

#### Risk of injury, fire and poisoning

- Disconnect the vehicle battery before starting any kind of work.
- Before working on the heater, switch the heater off and let all hot components cool down.
- The heater must not be operated in enclosed rooms, e.g. in the garage or multi-storey car park.



### CAUTION!

#### Safety instructions for installation and operation

- The heater must only be installed by a JE partner authorised by the manufacturer according to the instructions in this manual and possibly according to special installation recommendations; the same applies to any repairs to be carried out in the case of repairs or guarantee claims.
- Repairs by non-authorised third-parties

or with not original spare parts are dangerous and therefore not allowed. They result in expiry of the type permit of the heater; consequently, when installed in motor vehicles they can cause expiry of the vehicle operating licence.

- The following measures are not allowed:
  - Changes to components relevant to the heater.
  - Use of third-party components not approved by J. Eberspächer GmbH & Co. KG.
  - Nonconformities in installation or operation from the statutory regulations, safety instructions or specifications relevant to safe operation as stated in the installation instructions and operating instructions. This applies in particular to the electrical wiring, fuel supply, combustion air system and exhaust system.
- Only original accessories and original spare parts must be used during installation or repairs.
- Only original accessories and spare parts may be used for installation or repairs.
- Only the controls approved by Eberspächer may be used to operate the heater. The use of other controls can result in malfunctions.
- Before the heater is installed again in another vehicle, rinse the heater parts carrying water with clear water.

# AUXILIARY HEATER

## Hydronic M-II

- When carrying out electric welding on the vehicle, the plus pole cable at the battery should be disconnected and placed at ground to protect the controller.
- The heater must not be operated where there is a risk of an accumulation of flammable vapours or dust, for example close to
  - fuel depot
  - coal depot
  - wood depot
  - grain depots etc.
- The heater must be switched off when refuelling.
- When the heater is mounted in a safety housing etc., the installation compartment of the heater is not a stowage compartment and must be kept clear. In particular fuel canisters, oil cans, spray cans, gas cartridges, fire extinguishers, cleaning rags, items of clothing, paper etc. must not be stored or transported on or next to the heater.
- Defect fuses must only be replaced by fuses with the prescribed rating.
- If fuel leaks from the heater fuel system, arrange for the damage to be repaired immediately by a JE service partner.
- When topping up the coolant, only use the coolant permitted by the vehicle manufacturer, see the vehicle operating

manual. Any blending with unpermitted coolant can cause damage to the engine and heater.

- After-running of the heater must not be interrupted prematurely e.g. by pressing the battery disconnecting switch, apart from in the case of an emergency stop.

### Accident prevention

General accident prevention regulations and the corresponding workshop and operation safety instructions are to be observed.



# AUXILIARY HEATER

## Hydronic M-II

### Scope of supply

Quantity / Designation	Order number
1 Hydronic M8 Biodiesel	
12 Volt	25 2470 05 00 00
24 Volt	25 2471 05 00 00
To be ordered separately:	
1 Universal installation kit	25 2435 80 00 00
1 Control unit*	-
1 Hydronic M10	
12 Volt	25 2434 05 00 00
24 Volt	25 2435 05 00 00
To be ordered separately:	
1 Universal installation kit	25 2435 80 00 00
1 Control unit*	-
1 Hydronic M12	
12 Volt	25 2472 05 00 00
24 Volt	25 2473 05 00 00
To be ordered separately:	
1 Universal installation kit	25 2435 80 00 00
1 Control unit*	-

\* Control units see price list / accessories catalogue..



### Please note!

- The cable harness, Order No. 25 2435 80 06 00, is also required for vehicles used for transporting dangerous goods.
- Please consult the additional parts catalogue if any other parts are required for installation.

### Parts list for the „Scope of supply“ figure on page 9

#### Hydronic M8 Biodiesel heater scope of supply

Picture-No.	Designation
1	Heater
2	Metering pump
21	Tube, Ø 6 x 1. length 6 m
22	Transition piece Ø 3.5 / 5, (2 x)
-	Hose clamp Ø 10, (4 x)

#### Hydronic M10 / M12 heater scope of supply

Picture-No.	Designation
1	Heater
2	Metering pump

# AUXILIARY HEATER

## Hydronic M-II

### Universal installation kit scope of supply

Picture-No.	Designation
3	Relay 12 V / 24 V
4	Exhaust silencer
5	Cable tree, heater
6	Bracket, heater
7	Flexible exhaust pipe
8	Cable ties (10 x)
9	Pipe, Ø 6 x 1, length 1,5 m
10	Hose, Ø 5 x 3, length 0,5 m
11	Pipe, Ø 4 x 1, length 6 m
12	Hose, Ø 3,5 x 3, length 10 cm
13	Intake silencer for combustion air
14	Water hose
15	Water hose
16	Lead harness, metering pump
17	Lead harness, blower
18	Corrugated tube, Inner Ø 10 mm, length 2 m
19	Grommet
20	Bracket
-	Small parts

### Cable harnesses

A	„Controls“ lead harness
B	„Blower control“ lead harness
C	Positivecable
D	Negativecable
E	Connection, blower relay positive supply cable at the fuse holder
F	Connection at blower relay, terminal 85 (1-pole, brown)
G	Connection at blower relay, terminal 86 (1-pole, red/yellow)
H	Metering pump connection

# AUXILIARY HEATER

Hydronic M-II

## Scope of supply

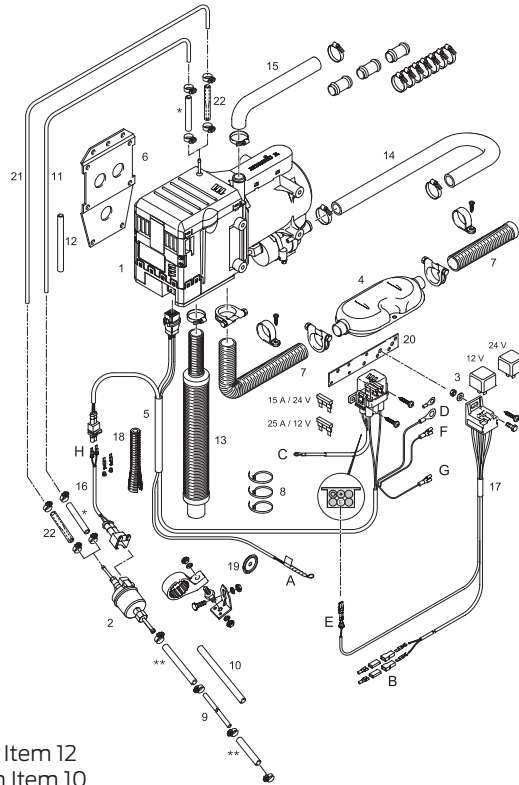

\* make from Item 12  
\*\*make from Item 10

# AUXILIARY HEATER

## Hydronic M-II

### Technical data

Heater type	<b>Hydronic M-II</b>				
Heater	Hydronic M8 Biodiesel				
Version	D 8 W				
Heating medium	Mixture of water and coolant (max. 50 % water, 50 % coolant)				
Control of the heat flow	Power	Large	Medium	Small	
Heat flow (watt) Figures for operation with diesel fuel. If operated with FAME the heat flow can reduce by up to 15 %.	8000	5000	3500	1500	
Fuel consumption (l/h)	0.90	0.65	0.40	0.18	
Electrical power (watt)	in operation	55	46	39	35
	at start – after 25 Sek.	200			
	in the control phase “OFF”	32			
Rated voltage	in the control phase “OFF”		12 Volt	20 Volt	
Operating range · Lower voltage limit: An undervoltage protection in the controller switches the heater off on reaching the voltage limit.			10 Volt	20 Volt	
			15 Volt	30 Volt	
Tolerable operating pressure	up to 2 bar overpressure				
Flow rate of the water pump at 0.14 bar	1400 l/h				

# AUXILIARY HEATER

## Hydronic M-II

· Minimum water flow rate of the heater		500 l/h	
Fuel – see also “Fuel quality diesel heaters” page 27		Commercially available diesel (DIN EN 590) FAME – for diesel engines according to DIN EN 14 214	
Tolerable ambient temperature		Operation	Not running
Heater / Control box	Diesel	–40 °C to +80 °C	–40 °C to +85 °C
	FAME	–8 °C to +80 °C	–40 °C to +85 °C
Dosing pump	Diesel	–40 °C to +50 °C	–40 °C to +85 °C
	FAME	–8 °C to +50 °C	–40 °C to +85 °C
Interference suppression class		interference suppression class 5 to DIN EN 55 025	
Weight with controller and water pump, without dosing pump		approx. 6.2 kg	

**CAUTION!**

**Safety instructions for technical data!**  
 Failure to comply with the technical data can result in malfunctions.

**Please note!**

Provided no limit values are given, the technical data listed is subject to the tolerances usually applicable to heaters of ±10% for nominal voltage, ambient temperature 20 °C and reference altitude Esslingen.

# AUXILIARY HEATER

## Hydronic M-II

### Technical data

Heater type	<b>Hydronic M-II</b>				
Heater	Hydronic M10				
Version	D 10 W				
Heating medium	Mixture of water and coolant (max. 50 % water, 50 % coolant)				
Control of the heat flow	Power	Large	Medium	Small	
Heat flow (watt)	9500	8000	3500	1500	
Fuel consumption (l/h)	1.2	0.9	0.4	0.18	
Electrical power (watt)	in operation	86	60	39	
		at start – after 25 Sek.			120
		in the control phase "OFF"			32
Rated voltage	12 Volt		24 Volt		
Operating range	10 Volt		20 Volt		
<ul style="list-style-type: none"> <li>Lower voltage limit: An undervoltage protection in the controller switches the heater off on reaching the voltage limit.</li> </ul>	15 Volt		30 Volt		
<ul style="list-style-type: none"> <li>Upper voltage limit: An overvoltage protection in the controller switches the heater off on reaching the voltage limit.</li> </ul>					
Tolerable operating pressure	up to 2 bar overpressure				
Flow rate of the water pump at 0.14 bar	1400 l/h				

# AUXILIARY HEATER

## Hydronic M-II

· Minimum water flow rate of the heater	500 l/h	
Fuel – see also “Fuel quality diesel heaters” page 27	Commercially available diesel (DIN EN 590)	
Tolerable operating temperature	Operation	Not running
	Heater / Control box	–40 °C to +85 °C
	Dosing pump	–40 °C to +85 °C
Interference suppression class	interference suppression class 5 to DIN EN 55 025	
Weight with controller and water pump, without dosing pump	approx. 6.2 kg	

 **CAUTION!**

**Safety instructions for technical data!**

Failure to comply with the technical data can result in malfunctions.

 **Please note!**

Provided no limit values are given, the technical data listed is subject to the tolerances usually applicable to heaters of ±10% for nominal voltage, ambient temperature 20 °C and reference altitude Esslingen.

# AUXILIARY HEATER

## Hydronic M-II

### Technical data

Heater type	<b>Hydronic M-II</b>						
Heater	Hydronic M12						
Version	D 12 W						
Heating medium	Mixture of water and coolant (max. 50 % water, 50 % coolant)						
Control of the heat flow	Power	Large	Medium 1	Medium 2	Medium 3	Small	
Heat flow (watt)	12000	9500	5000	5000	1500	1200	
Fuel consumption (l/h)	1.5	1.2	0.65	0.40	0.18	0.15	
Electrical power (watt)	in operation	132	60	86	46	34	34
	at start – after 25 Sek.	120					
	in the control phase "OFF"	32					
Rated voltage	12 Volt			24 Volt			
Operating range	10 Volt			20 Volt			
<ul style="list-style-type: none"> <li>Lower voltage limit: An undervoltage protection in the controller switches the heater off on reaching the voltage limit.</li> </ul>							
<ul style="list-style-type: none"> <li>Upper voltage limit: An overvoltage protection in the controller switches the heater off on reaching the voltage limit.</li> </ul>	15 Volt			30 Volt			
Tolerable operating pressure	up to 2 bar overpressure						
Flow rate of the water pump at 0.14 bar	1400 l/h						



# AUXILIARY HEATER

## Hydronic M-II

Minimum water flow rate of the heater	500 l/h	
Fuel – see also “Fuel quality diesel heaters” page 27	Commercially available diesel (DIN EN 590)	
Tolerable operating temperature	Operation	Not running
	Heater / Control box	–40 °C to +85 °C
	Dosing pump	–40 °C to +85 °C
Interference suppression class	interference suppression class 5 to DIN EN 55 025	
Weight with controller and water pump, without dosing pump	approx. 6.2 kg	

 **CAUTION!**

**Safety instructions for technical data!**

Failure to comply with the technical data can result in malfunctions.

 **Please note!**

Provided no limit values are given, the technical data listed is subject to the tolerances usually applicable to heaters of ±10% for nominal voltage, ambient temperature 20 °C and reference altitude Esslingen.



# AUXILIARY HEATER

## Hydronic M-II

### Installation location

The installation location for the heater is the engine compartment. The heater must be mounted below the min. cooling water level (compensation tank, cooler, vehicle heat exchanger) for automatic venting of the heat exchanger of the heater and the water pump.



### Please note!

- In a truck, the water heater is preferably fastened underneath the driver's cab in the longitudinal beam near the vehicle engine.
- The regulations and safety instructions to be observed for this chapter are stated on page 4 – 7.
- The installation suggestions made in the installation instructions are examples. Other installation locations are possible if they correspond to the installation requirements stated in these installation instructions.
- Other installation information (e.g. for boats and ships) is available from the manufacturer on request.
- Please take note of the installation locations together with the operating and storage temperatures.

### Installation example heater in a truck

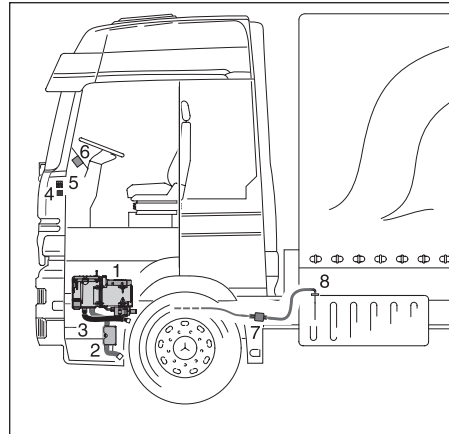

- 1 Heater
- 2 Exhaust pipe with exhaust silencer
- 3 Combustion air intake silencer
- 4 Fan relay
- 5 Fuse bracket
- 6 Controls
- 7 Dosing pump
- 8 Tank connection

### Installing the 24 V heater in a vehicle for the transport of dangerous goods as per ADR

For installation of the heater in vehicles for the transport of dangerous goods, the regulations of ADR / ADR99 must be observed.

With the appropriate electrical wiring the heater fulfils the ADR regulations, see the “Additional Regulations” on Page 6, the “Control and Safety Devices” on Page 29 and the “Circuit Diagrams” on Page 34 and 39.

Detailed information about the ADR regulations is contained in leaflet no. 25 2161 95 15 80.

# AUXILIARY HEATER

## Hydronic M-II

### Possible installation positions

The heater should preferably be installed in the normal position, horizontal with the exhaust connection down to the bottom. Depending on the installation conditions, the heater can also be mounted in the permitted swivel range, see diagram.

When the heater is operating, the shown normal or maximum installation positions can be varied briefly by up to  $+15^\circ$  in all directions. Such deviations caused by the inclined position of the vehicle do not impair the heater functions in any way.

### Normal position with permitted swivel range

- Swivel range from the normal position swivelled up to max.  $85^\circ$  downward – the heater's water outlet socket is horizontal. The water pump's water inlet socket must face downward.
- Swivel range from the normal position swivelled up to max.  $90^\circ$  to the left about the longitudinal axis – the water outlet socket is at the top of the heater and faces the left.

# AUXILIARY HEATER

Hydronic M-II

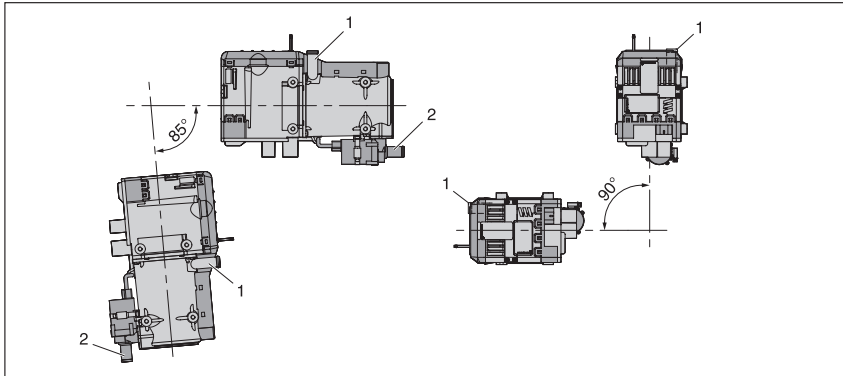

- 1 Water outlet socket, heater
- 2 Water inlet socket, water pump

# AUXILIARY HEATER

## Hydronic M-II

### Mounting and fastening

Fix the unit holder from the installation kit to the heater using 4 hexagon screws M8 and 4 spring washers (tightening torque 12+0.5 Nm).

Fix the heater and the mounted unit holder in a suitable 5 place in the vehicle using 5 hexagon screws M8, 5 spring washers and 5 hexagon nuts M8 (tightening torque 12+0.5 Nm).

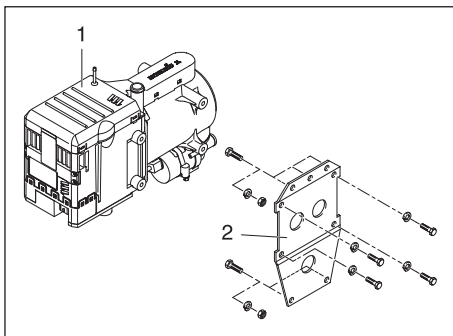

1 Heater  
2 Heaterbracket

### Nameplate

The nameplate is on the front and the 2nd nameplate (duplicate) is fixed to the side of the control box / fan unit. If required, the installer can stick the duplicate nameplate in a clearly visible position elsewhere on the heater or near to the heater.



**Please note!**

The regulations and safety instructions to be observed for this chapter are stated on page 5.

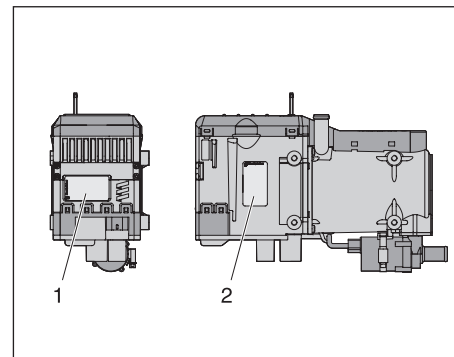

1 Originalnameplate  
2 2nd nameplate (dupliate)

# AUXILIARY HEATER

## Hydronic M-II

### Connection to the cooling water circuit

The heater is connected to the cooling water circuit in the water feed pipe from the vehicle engine to the heat exchanger. There are three possible alternative installations here.

The alternatives are described on pages 16 – 18.



### DANGER!

### Risk of injuries and burns!

It is possible for the coolant and components of the coolant circuit to get very hot.

- Parts conveying water must be routed and fastened in such a way that they pose no temperature risk to man, animals or material sensitive to temperature from radiation / direct contact.
- Before working on the coolant circuit, switch the heater off and wait until all components have cooled down completely, if necessary where safety gloves.



### Please note!

- When installing the heater, please take note of the direction of flow of the coolant circuit.
  - Fill the heater and water hoses with coolant before connecting to the coolant circuit.
  - Route the water hoses without any kinks, and in a rising position if possible. When routing the water pipes, observe a sufficient clearance to hot vehicle parts.
  - Protect all water hoses / water pipes from chafing and from extreme temperatures.
  - Secure all hose connections with hose clips. (tightening torque = 1.5 Nm)
  - After the vehicle has been operating for 2 hours or travelled 100 km, tighten the hose clips again.
  - The minimum water flow rate is only guaranteed if the temperature difference of the heating medium does not exceed 15 K between water inlet and water outlet during heating.
  - Only overpressure valves with an opening pressure of min. 0.4 – max. 2 bar may be used in the coolant circuit.
  - The coolant liquid must contain at least 10 % antifreeze- ze all year round as corrosion protection.
  - The cooling liquid must contain sufficient antifreeze for low temperatures.
- Before commissioning the heater or after changing the cooling liquid, the whole coolant circuit including heater must be vented free of bubbles according to the instructions issued by the vehicle manufacturer.
  - Only top up with coolant approved by the vehicle manufacturer.

# AUXILIARY HEATER

## Hydronic M-II

### Connection to the cooling water circuit

#### Integrate the heater with non-return valve in the coolant circuit

Disconnect the water feed pipe from the vehicle engine to the vehicle heat exchanger and insert the non-return valve. Connect the heater with its water pipes to the non-return valve.

#### Advantage:

Simple installation.

#### Disadvantage:

The coolant flows through the vehicle engine constantly so that in large vehicle engines, adequate cab heating is scarcely possible.

#### Heating characteristics:

When the heater is switched on, the heat flows through the vehicle heat exchanger and the vehicle engine. Once the cooling water has reached a temperature of approx. 55 °C, depending on the selected fan setting the vehicle fan is switched on and the heat is also conveyed to the passenger compartment.

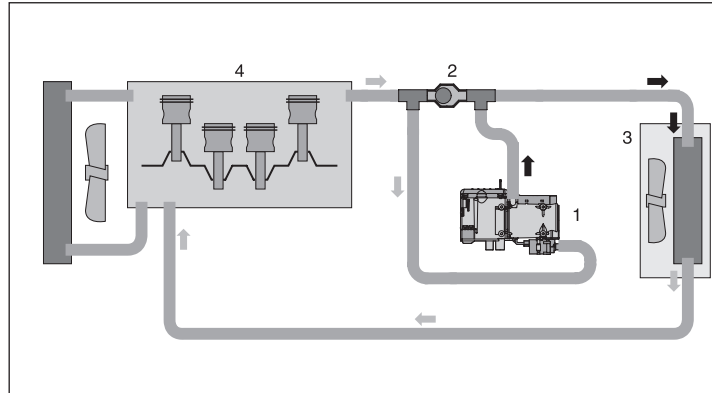

- 1 Heater
- 2 Non-return valve
- 3 Heatexchanger
- 4 Vehicleengine



#### Please note!

Non-return valve must be ordered separately, see additional parts catalogue for Order No.



# AUXILIARY HEATER

Hydronic M-II

## Connection to the coolant circuit

### Integrate the heater with non-return valve, thermostat and T-piece in the coolant circuit

Disconnect the water feed pipe from the vehicle engine to the vehicle heat exchanger and insert the non-return valve.

Disconnect the water return pipe from the heat exchanger to the vehicle engine and insert the T-piece.

Connect the heater and thermostat with water hoses to the non-return valve and T-piece as shown in the diagram.

### Option:

In addition a solenoid can be fitted in the water circuit. When open, this bypasses the thermostat and pre-heats the engine as soon as the heater starts to work.

### Heating characteristics

#### • Small coolant circuit: fast heating of the passenger compartment

Initially the heat produced by the heater is only conveyed to the vehicle heat exchanger up to a cooling water temperature of approx. 70 °C.

The vehicle fan switches on at approx.

55 °C.

#### • Large cooling water circuit: heating of the passenger compartment and additional engine pre-heating

If the cooling water temperature continues to increase, the thermostat slowly changes over to the large circuit (full change-over at approx. 75 °C).

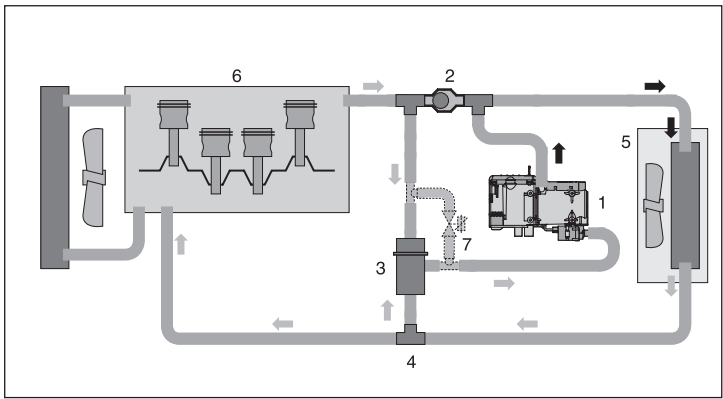

- 1 Heater
- 2 Non-return valve
- 3 Thermostat
- 4 T-piece

- 5 Heat exchanger
- 6 Vehicle engine
- 7 Solenoid (option)

# AUXILIARY HEATER

## Hydronic M-II



### Please note!

The thermostat, non-return valve and T-piece must be ordered separately, see additional parts catalogue for Order No. The solenoid valve has to be purchased through the trade.

### Thermostat functions

#### Small coolant circuit

Cooling water temperature  $< 70\text{ }^{\circ}\text{C}$ :  
Connection no. 1: open to the heater  
Connection no. 2: open to the T-piece  
Connection no. 3: closed to the non-return valve

#### Large coolant circuit

Cooling water temperature  $> 75\text{ }^{\circ}\text{C}$ :  
Connection no. 1: open to the heater  
Connection no. 2: closed to the T-piece  
Connection no. 3: open to the non-return valve

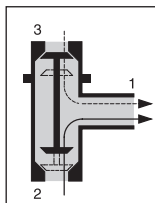

- 1 Connection to the heater
- 2 Connection to the T-piece
- 3 Connection to the non-return valve



### Please note!

Integrate the thermostat into the water circuit with connections (1) (2) and (3) as shown in the diagram.

# AUXILIARY HEATER

Hydronic M-II

## Connection to the coolant circuit

### Integrate the heater with a solenoid in the coolant circuit

Disconnect the water flow hose from the vehicle's engine to the vehicle's heat exchanger and insert two T-pieces. Connect the T-pieces with a hose. Disconnect the water return pipe from the heat exchanger to the vehicle engine and insert the solenoid. Connect the heater and the solenoid to the T-piece with water pipes, as shown in the diagram.

### Option:

In addition, a non-return valve with connection hoses between the two T-pieces can be inserted in the cooling water circuit. This prevents the loss of effective vehicle heating when the heater is switched off.

### Heating characteristics

By installing the electric solenoid valve, temperature-independent choice between the small cooling water circuit (driver's cab) and large cooling water circuit (vehicle engine with driver's cab) is possible.

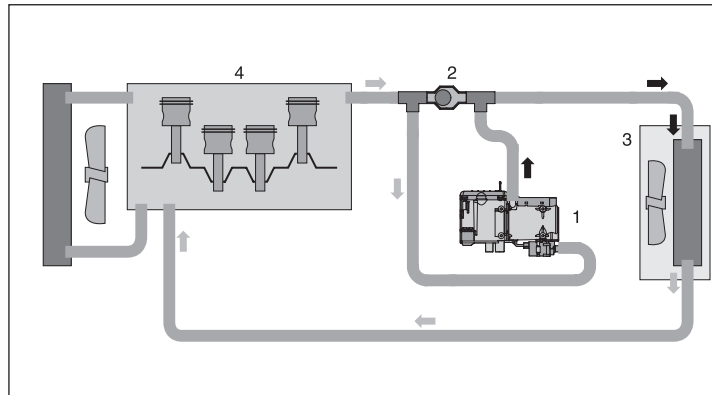

- 1 Heater
- 2 Solenoid
- 3 T-piece
- 4 Heatexchanger
- 5 Vehicleengine
- 6 Non-returnvalve (option)



### Please note!

The T-pieces and non-return valve must be ordered separately. For Order No., see additional parts catalogue. The solenoid valve has to be purchased through the trade.

# AUXILIARY HEATER

## Hydronic M-II

### Exhaust system

(Exhaust diagram see page 22)

### Mounting the exhaust system

The universal installation kit includes a flexible exhaust pipe, inner Ø 30 mm, 1300 mm long and an exhaust silencer.

The flexible exhaust pipe can be shortened to 20 cm or lengthened to max. 1.8 m, depending on the installation conditions (See sketch on page 22).

Fasten the exhaust silencer to a suitable position in the vehicle.

Route the flexible exhaust pipe from the heater to the exhaust silencer and fasten with pipe clips.

If necessary, also fasten the flexible exhaust pipe with pipe clips at suitable positions in the vehicle.

Connect the exhaust end pipe to the exhaust silencer with an end sleeve and fasten with a pipe clip.



**DANGER!**

### Risk of injuries and burns!

Every type of combustion produces high temperatures and toxic exhaust fumes.

This is the reason why the exhaust system must be installed according to these instructions.

- Do not perform any work on the exhaust system while the heater is working.
- Before working on the exhaust system, first switch the heater off and wait until all parts have cooled down completely, wear safety gloves if necessary.
- Do not inhale exhaust fumes.



**CAUTION!**

### Safety instructions for the exhaust system!

- The exhaust outlet must end in the open air.
- The exhaust pipe must not protrude beyond the lateral limits of the vehicle.
- Install the exhaust pipe sloping slightly downwards. If necessary, make a drain hole approx. Ø 5 mm at the lowest point to drain off condensation.
- Important functional parts of the vehicle must not be impaired (keep sufficient clearance).
- Mount the exhaust pipe with sufficient clearance to heat-sensitive parts. Pay particular attention to fuel pipes (plastic or metal), electrical cables and brake hoses etc.!
- Exhaust pipes must be fastened safely (recommended clearance of 50 cm) to avoid damage from vibrations.

- Route the exhaust system so that the emitted fumes are not sucked in with the combustion air.
- The mouth of the exhaust pipe must not get clogged by dirt and snow.
- The mouth of the exhaust pipe must not point in the direction of travel.
- Always fasten the exhaust silencer to the vehicle.



**Please note!**

- Comply with the regulations and safety instructions for this chapter on page 4 – 7.
- The exhaust end pipe should be much shorter than the flexible exhaust pipe from the heater to the ex- haust silencer.
- Use pipe clips to secure all connections in the exhaust system.

### Combustion air system

Mounting the combustion air system  
The universal installation kit includes an intake silencer, inner  $\varnothing$  25 mm for the combustion air.

The intake silencer must be installed and, if necessary, can be extended by up to 2 m max using a flexible pipe (inner  $\varnothing$  25 mm) and a connection pipe (outer  $\varnothing$  24 mm) – not included in the scope of supply.

Fasten the intake silencer and where applicable the flexible pipe at suitable points in the vehicle using fastening clips and cable ties.



#### Please note!

- Comply with the regulations and safety instructions for this chapter on page 4 – 7.
- Extension of the intake silencer is not allowed if mainly heating mode is used at high altitudes (over 1000 m asl).
- Use pipe clips to secure all connections in the combustion air system.



#### CAUTION!

#### Safety instructions for the combustion air system!

- The combustion air opening must be free at all times.
- Position the combustion air intake to be sure that exhaust fumes cannot be sucked in with the combustion air.
- The combustion air intake must not get clogged with dirt and snow.
- Install the combustion air intake system sloping slightly downwards.
- If necessary, make a drain hole approx.  $\varnothing$  5 mm at the lowest point to drain off condensation.
- Avoid tight bends when laying the intake silencer and flexible pipe.

# AUXILIARY HEATER

## Hydronic M-II

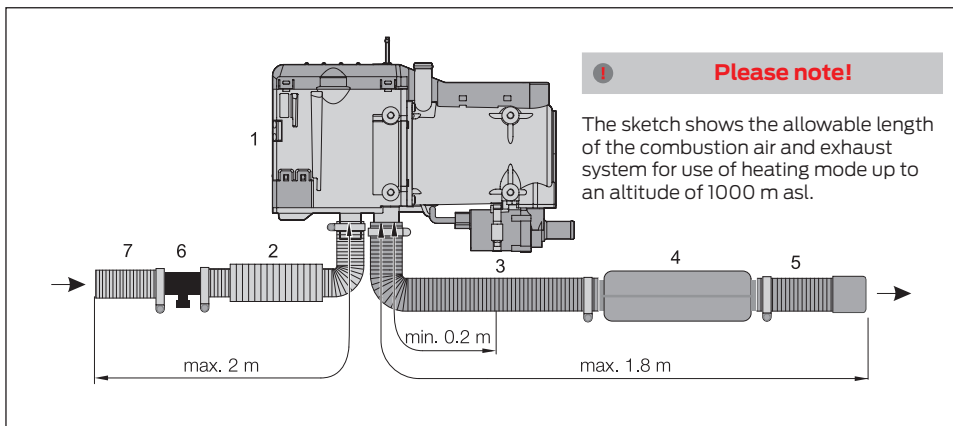

1 Heater

2 Intake silencer for the combustion air

3 Flexible exhaust pipe

4 Exhaust silencer

5 Flexible exhaust end pipe with end sleeve

6 Adapter with condensate outlet  
(Order No. 22 1050 89 40 00)

7 Flexible pipe (Order No. 10 2114 21 00 00)

# AUXILIARY HEATER

## Hydronic M-II

### Fuel supply

#### Mounting the dosing pump, routing the fuel pipes and mounting the fuel tank

The following safety instructions must be observed when mounting the dosing pump, routing the fuel pipes and mounting the fuel tank.



### DANGER!

#### Risk of fire, explosion, poisoning and injuries!

Caution when handling fuel.

- Switch off the vehicle engine and heater before refueling and before working on the fuel supply.
- No naked lights when handling fuel.
- Do not smoke.
- Do not inhale fuel vapours.
- Avoid any contact with the skin.



### CAUTION!

#### Safety instructions for routing the fuel pipes!

- Only use a sharp knife to cut off fuel hoses and pipes. Interfaces must not be crushed and must be free of burrs.
- The fuel pipe from the dosing pump

to the heater should be routed at a continuous rise.

- Fuel pipes must be fastened safely to avoid any damage and / or noise production from vibrations (recommended clearance of approx. 50 cm).
- Fuel pipes must be protected from any mechanical damage.
- Route the fuel pipes so that any distortion of the vehicle, engine movements etc. cannot have any lasting effect on the service life.
- Parts carrying fuel must be protected from interfering heat.
- Never route or fasten the fuel pipes to the heater or vehicle exhaust system. When the systems cross, always ensure there is a sufficient heat clearance. If necessary, install heat deflection plates.
- Dripping or evaporating fuel must never be allowed to collect on hot parts or ignite on electric systems.
- When connecting fuel pipes with a fuel hose, always mount the fuel pipes in a butt joint to prevent any bubbles from forming.

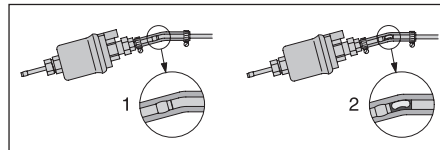

1 Correct connection

2 Incorrect connection – bubble formation



### Please note!

- Deviations from the instructions stated here are not allowed.
- Failure to comply can result in malfunctions.
- When replacing the Hydronic M (Hydronic 10) with the Hydronic M-II, the metering pump must be replaced too.

#### Safety instructions for fuel pipes and fuel tanks in buses and coaches

- In buses and coaches, fuel pipes and fuel tanks must not be routed through the passenger compartment or driver's cab.
- Fuel tanks in buses and coaches must be positioned in such a way that the exits are not in direct danger from a possible fire.



### Please note!

Comply with the regulations and safety instructions for this chapter on page 4 – 7.

# AUXILIARY HEATER

## Hydronic M-II

### Fuel supply

Fuel feed point with T-piece from the fuel supply line from the tank fitting to the vehicle engine

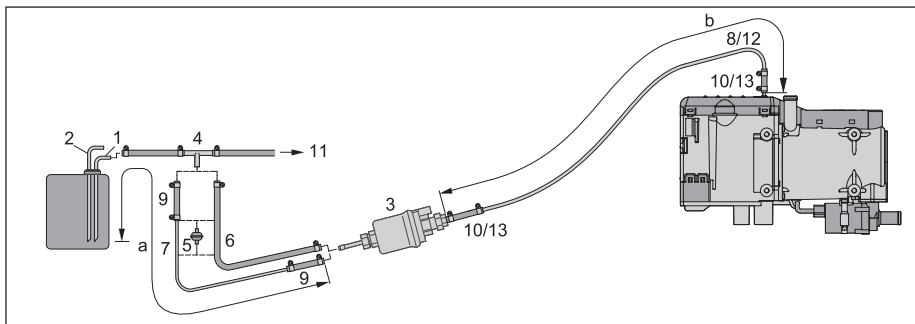

- 1 Fuel feed pipe from tank connection
- 2 Fuel return pipe to the tank connection
- 3 Dosing pump
- 4 T-piece
- 5 Fuel filter
- 6 Fuel hose, 5 x 3 (di = Ø 5 mm)
- 7 Fuel pipe, 6 x 1 (di = Ø 4 mm)
- 8 Fuel pipe, 4 x 1 (di = Ø 2 mm)
- 9 Fuel hose, 5 x 3 (di = Ø 5 mm), approx. 50 mm long

- 10 Fuel hose, 3,5 x 3 (di = Ø 3.5 mm), approx. 50 mm long
- 11 To the engine, mechanical fuel or injection pump.

Required for Hydronic M8 biodiesel for operation with FAME only.

- 12 Fuel pipe blue, 6 x 1 (di = Ø 4 mm)
- 13 Transition piece 3,5 / 5

### Possible pipe lengths

#### Intake side

a = max. 2 m

#### Pressure side

b = min. 1.5 m – max. 6 m



### Please note!

- Insert the T-piece (4) in the fuel flow line upstream of the feed pump. T-piece is not included in the “installation kit” scope of supply. The order no. is given in the additional parts catalogue.
- Fuel filter, Item (5), is required for contaminated fuel only. Fuel filter is not included in the “installation kit” scope of supply. The order no. is given in the additional parts catalogue.
- Items (12) and (13) are only included in the “Hydronic M8 Biodiesel” heater’s scope of supply.



# AUXILIARY HEATER

Hydronic M-II

## Installation position of the T-piece

Use the installation positions shown in the diagram when inserting a T-piece.

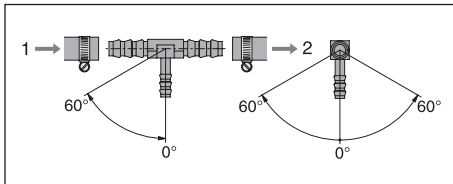

- 1 Direction of flow from the fuel tank
- 2 Direction of flow to the vehicle engine

# AUXILIARY HEATER

## Hydronic M-II

### Fuel supply

#### Fuel feed point with tank connection – ascending pipe, integrated in the vehicle tank

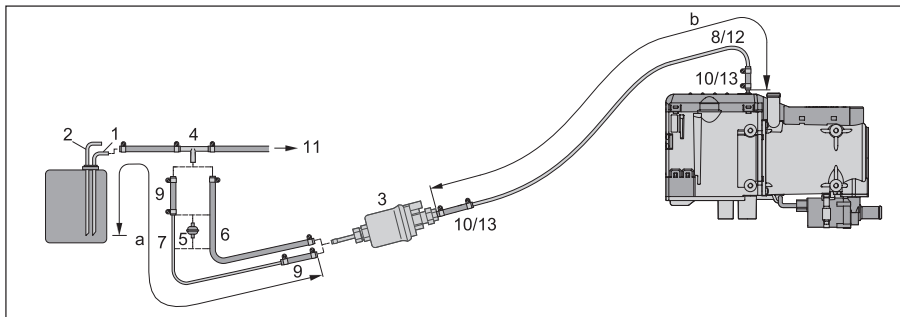

1 Tank connection for metal tank – di = Ø 4 mm, da = Ø 6 mm

2 Dosing pump

3 Fuel filter

4 Fuel hose, 5 x 3 (di = Ø 5 mm)

5 Fuel pipe, 6 x 1 (di = Ø 4 mm)

6 Fuel hose, 5 x 3 (di = Ø 5 mm), approx.

50 mm long

7 Fuel pipe, 4 x 1 (di = Ø 2 mm)

8 Fuel hose, 3,5 x 3 (di = Ø 3.5 mm), approx. 50 mm

Required for Hydronic M8 biodiesel for operation with FAME only.

9 Fuel pipe blue, 6 x 1 (di = Ø 4 mm)

10 Transition piece 3,5 / 5

### Possible pipe lengths

#### Intake side

a = max. 2 m

#### Pressure side

b = min. 1.5 m – max. 6 m



#### Please note!

- Item (1), tank connection for metal tank, is not included in the scope of supply “installation kit”. Order no. see extra parts catalogue.
- Fuel filter, Item (3), is required for contaminated fuel only. Fuel filter is not included in the “installation kit” scope of supply. The order no. is given in the additional parts catalogue.
- Items (9) and (10) are only included in the “Hydronic M8 Biodiesel” heater’s scope of supply.
- When installing tank connection maintain a minimum distance of  $50 \pm 2$  mm from the end of the riser pipe and the bottom of the tank.

# AUXILIARY HEATER

## Hydronic M-II



### CAUTION!

#### Safety instructions for the fuel supply!

- The fuel must not be conveyed by gravity or overpressure in the fuel tank.
- Withdrawal of fuel after the vehicle's fuel pump is not allowed.
- When the pressure in the fuel pipe is more than 4.0 bar or there is a non-return valve in the return pipe (in the tank), a separate tank connection must be used.
- When using a T-piece in a plastic pipe, always use support sleeves in the plastic. Connect the T-piece and the plastic pipe with corresponding fuel hoses and secure with hose clips.

#### Fuel supply

#### Installation position of the dosing pump

Always mount the dosing pump with the pressure side rising upwards. Every installation position over 15° is allowed, although an installation position between 15° and 35° is preferable.

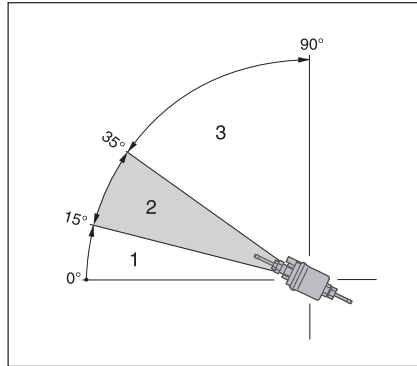

1. Installation position between 0° and 15° is not allowed.
2. Preferred installation position in range 15° to 35°
3. Installation position in range 35° to 90° is allowed.

#### Possible intake and pressure height of the dosing pump

Pressure height from vehicle tank to dosing pump: a = max. 1000 mm  
Intake height for non-pressurised vehicle tank: b = max. 750 mm  
Intake height for a vehicle tank with withdrawal by negative pressure (valve with 0.03 bar in the tank lid): b = max. 400 mm  
Pressure height from the dosing pump to the heater: c = max. 2000 mm



### Please note!

Check tank venting.

# AUXILIARY HEATER

## Hydronic M-II

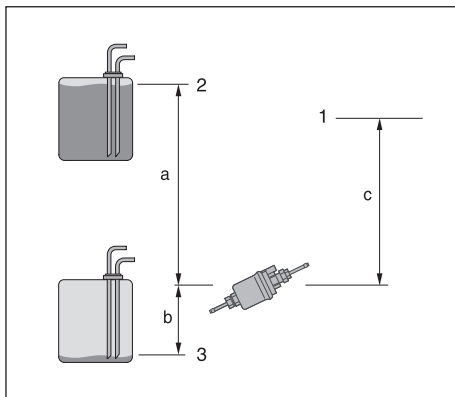

- 1 Connection to heater
- 2 Max. fuel level
- 3 Min. fuel level



### CAUTION!

#### Safety instructions for installing the dosing pump

- Always mount the dosing pump with the pressure side rising upwards – minimum incline 15°.
- Protect the dosing pump and filter from intolerable heat, do not mount near to the silencers and exhaust pipes.

#### Fuel quality

- Hydronic M8 Biodiesel, M10 and M12 heaters easily process standard diesel fuel to EN 590.
- During the winter months the diesel fuel is adapted to low temperatures from 0 °C to –20 °C. Problems can therefore only arise if outdoor temperatures are extremely low – which also applies to the vehicle's engine – please refer to the vehicle manufacturer's regulations.
- In special cases and at outdoor temperatures above 0 °C the heater can also be run on heating oil EL according to DIN 51603.
- If the heater is run from a separate tank, please comply with the following rules:
  - If outdoor temperatures over 0 °C: Use diesel fuel according to DIN EN 590.
  - If outdoor temperatures from 0 °C to –20 °C: Use winter diesel fuel according to DIN EN 590.
  - If outdoor temperatures –20 °C to –40 °C: Use Arctic Diesel or Polar Diesel.



### Please note!

- It is not permitted to add used oil!
- After refuelling with winter or cold diesel or the listed blends, the fuel pipes and the dosing pump must be filled with the new fuel by letting the heater run for 15 mins!

#### Operation with biodiesel

**(FAME for diesel engines according to DIN EN 14 214)**

#### Hydronic M8 Biodiesel

The heater is approved for operation with biodiesel up to a temperature of –8°C (the flowability reduces at temperatures below 0 °C).



### Please note!

- When using 100 % biodiesel, the heater should be run on diesel fuel twice a year (in the middle and at the end of a heating period) to burn off possibly accumulated biodiesel deposits. To do so, let the vehicle tank run almost empty and fill with diesel fuel without adding any biodiesel. While running on this tank filling, switch the heater on 2 to 3 times for 30 minutes at a time at the highest temperature setting.
- If constantly operated with diesel / biodiesel mixtures of up to 50 % biodiesel, intermediate operation with pure diesel fuel is not necessary.

#### Hydronic M10 / Hydronic M12

Both heaters are not approved for operation with biodiesel. Up to 10 % biodiesel may be added.

# AUXILIARY HEATER

## Hydronic M-II

### Operating instructions

The heater is operated by a control unit. The control unit is accompanied by detailed operating instructions which you will receive from the company installing the heater.

### Initial commissioning

The following points are to be checked by the company installing the heater during initial commissioning.

- After installation of the heater, the coolant circuit and the whole fuel supply system must be vented carefully. Comply with the instructions issued by the vehicle manufacturer.
- Open the coolant circuit before the trial run (set the temperature control to "WARM").
- During the trial run of the heater, check all water and fuel connections for leaks and firm fitting.
- If the heater shows a fault during operation, find and eliminate the cause of the fault using a diagnosis unit (Contact JE service partner).

### Important instructions for operation

#### Safety checks before the start

After a longer interval in operations (after the summer months) the fuse must be put in position and / or the heater connected

up to the battery. Check that all parts fit firmly (tighten screws where necessary). Check the fuel system visually for any leaks.

### Before switching on

Before switching on or pre-programming the heater, adjust the heating control in the vehicle to "WARM" (maximum setting) and the fan to "SLOW" (low power consumption).

In vehicles with automatic heating, adjust the heating control to "MAX" and open the heating vents before switching the ignition off.

### Temperature drop (optional)

Temperature lowering only becomes active while the vehicle is running and if the heater (independent heater mode) is switched on. The control stages are reached earlier and the heater's control action is adjusted to the lower heat requirement.

The temperature can be lowered by connecting the positive cable (D+) to connector B2, terminal C3 of the heater cable harness (see circuit diagrams, Page 32 and 34).

### Heating mode at high altitudes – up to 3500 m asl

The combustion behaviour of the heater changes with increasing altitude, due to the lower air density.

The heater has an automatic altitude detection device which it uses to automatically compensate for the change in air density, i.e. the combustion ratio between fuel and air is adapted to the ambient conditions by reducing the fuel quantity.



### Please note!

- The usual switching limit for altitude detection lies between 1000 m asl and 2000 m asl and solely depends on the local climatic conditions.
- The maximum heating output of the Hydronic M10 / M12 in "Altitude Mode" is 8.5 kW.
- The Hydronic M8 Biodiesel does not have an altitude detection device. Unrestricted heating mode is possible up to 1500 m asl.
- Heaters suitable for high altitudes have "H Kit" marked on the side of the nameplate.

# AUXILIARY HEATER

## Hydronic M-II

### Description of functions

#### Switching on

On being switched on, the switch-on check is displayed in the control unit. The heater starts, whereby the water pump and the combustion air blower start up first.

The glow phase of the glow pencils begins simultaneously with distribution of the combustion air.

The metering pump starts fuel feed somewhat delayed. The glow pencils are switched off if a stable flame has formed in the combustion chamber.

#### Heating mode

After starting, the heater runs with "POWER" stage until the water temperature exceeds the "POWER" / „HIGH" changeover threshold.

#### Hydronic M8 Biodiesel / M10

Then, depending on the heat requirement, the heater switches to the "HIGH – MEDIUM – LOW – OFF" stages.

#### Hydronic M12

Then, depending on the heat requirement, the heater switches to the "HIGH –

MEDIUM 1 / MEDIUM 2 / MEDIUM 3 – LOW – OFF" stages.

If the heating requirement in the "LOW" stage is so small that the cooling water temperature reaches 86 °C, the heater switches from "LOW" to "OFF".

An after-run of approx. 180 seconds follows.

The water pump remains active until the controlled start. If the cooling water has cooled to approx. 72 °C, the Hydronic M8 / M10 heater starts in "MEDIUM" stage, the Hydronic M12 heater starts in "MEDIUM 1" stage.

If the cooling water temperature reaches approx. 55 °C the temperature sensor switches the vehicle fan on.

#### Switching off

After switching off, the heater briefly switches to "LOW" stage to reduce emissions and smoke formation.

This process can take up to 40 seconds maximum if the fuel quantity is constantly reduced.

Once this process has finished the heater starts the after-run for 180 seconds.

During the after-run both glow plugs are switched on alternately.



### Please note!

In independent heater mode (vehicle engine and heater are switched on), always ensure that the heater is completely switched off before entering a petrol station area.

### Control and safety devices

The heater is equipped with the following control and safety devices:

- If the heater does not ignite within 74 seconds after starting the fuel pump, the start is repeated. If the heater still does not ignite after another 65 seconds, the heater is switched off.\*
- After an unacceptable number of failed start attempts, the controller is locked.\*\*
- If the flame goes off by itself during operation, the heater is restarted. If the heater does not ignite within 74 seconds after the fuel pump has started again, the heater is switched off.\*
- After an unacceptable number of failed start attempts, the controller is locked.\*\*
- In the case of overheating (e.g. lack of water, poorly vented coolant circuit), the overheating sensor triggers, the fuel supply is interrupted and the heater switched off.\*

Once the cause of overheating has

# AUXILIARY HEATER

## Hydronic M-II

been eliminated, the heater can be re-started by switching off and on again (on condition that the heater has cooled down again sufficiently, cooling water temperature <72 °C). After the heater has been switched off for overheating an unacceptable number of times, the controller is locked.\*

- The heater is switched off if the upper or lower voltage limit is reached.\*
- The heater does not start up if the electric cable to the metering pump is interrupted.
- If one of the two glow plugs is defective the start sequence takes place with one glow plug only.
- The speed of the fan motor is monitored continuously. If the blower motor does not start up if it is blocked, or if the speed differs by > 12.5 % from the desired speed a safety lockout (shutdown on faults) takes place after 60 sec.\*
- The water pump's function is continuously monitored.  
\* This status can be remedied by briefly switching off and on again.  
\*\*For details of how to cancel the lock and to read out errors, refer to the Troubleshooting and Repair instructions of the heater.

- The speed of the fan motor is monitored continuously. If the blower motor does not start up if it is blocked, or if the speed differs by > 12.5 % from the desired speed a safety lockout (shutdown on faults) takes place after 60 sec.\*
- The water pump's function is continuously monitored.  
\* This status can be remedied by briefly switching off and on again.  
\*\*For details of how to cancel the lock and to read out errors, refer to the Troubleshooting and Repair instructions of the heater.



### Please note!

Do not switch the heater off and on again more than twice.

Forced shut-down for ADR / ADR99 operation

In vehicles for the transport of dangerous goods (e.g. tanker trucks), the heater must be switched off before the truck drives into a danger area (refinery, fuel service station, etc.)

### Failure to comply results in the heater switching off automatically when:

- The vehicle engine is switched off.
- An additional unit is started up (e.g. auxiliary drive for unloading pump etc.).
- A vehicle door is opened (ADR99 regulation, only in France).

The fan then runs on for max. 40 seconds.

### Emergency shutdown – EMERGENCY OFF

If an emergency shutdown – EMERGENCY OFF – is necessary during operation, proceed as follows:

- Switch the heater off with the control or
- pull the fuse out or
- disconnect the heater from the battery.

# AUXILIARY HEATER

## Hydronic M-II

### Heater wiring

The heater is to be connected up electrically according to the EMC directives.



### CAUTION!

#### Safety instructions for wiring the heater

EMC can be affected if the heater is not connected up correctly. For this reason, comply with the following instructions:

- Ensure that the insulation of electrical cables is not damaged. Avoid: chafing, kinking, jamming or exposure to heat.
- In waterproof connectors, seal any connector chambers not in use with filler plugs to ensure they are dirt- and water-proof.
- Electrical connections and ground connections must be free of corrosion and firmly connected.
- Lubricate connections and ground connections outside the heater interior with contact grease.



### Please note!

Comply with the following when wiring the heater and the control element:

- Electrical leads, switchgear and controllers must be arranged in the vehicle so that they can function

perfectly under normal operating conditions (e.g. heat exposure, moisture etc.).

- The following cable cross sections are to be used between the battery and heater. This ensures that the max. tolerable voltage loss in the cables does not exceed 0.5 V for 12 V or 1 V for 24 V rated voltage. Cable cross sections for a cable length of:
  - up to 5 m (plus cable + minus cable) = cable cross section 4 mm<sup>2</sup>
  - from 5 to 8 m (plus cable + minus cable) = cable cross section 6 mm<sup>2</sup>
- If the plus cable is to be connected to the fuse box (e.g. terminal 30), the vehicle cable from the battery to the fuse box must be included in rating the overall cable length and possibly re-dimensioned if necessary.
- Insulate unused cable ends.

#### Notes on rewiring the 12-pin cable harness connector

If, on replacing the Hydronic M (Hydronic 10) with the Hydronic M-II, the cable harness already installed in the vehicle is to be reused it is necessary to remove the 12-pin connector using the AMP release tool and to rewire it according to the following table (AMP Order No. 1-1579007-4).



# AUXILIARY HEATER

## Hydronic M-II

### 12-pin connection pin assignment

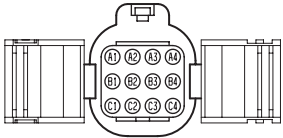

Connector is shown from the cable entry side.

Connection	Cable harness Hydronic M		Rewiring 12-pin connector	
		Cross-section Cable colour	Hydronic M PIN	Hydronic M-II PIN
Dosing pump		1,5 <sup>2</sup> gn	C4 →	A1
Terminal 31		4 <sup>2</sup> br	C3 →	A2*
Terminal 30		4 <sup>2</sup> rt	C2 →	A3*
Plus signal Main battery switch		1,5 <sup>2</sup> ws/rt	C1 →	A4*
Plus signal Solenoid valve relay		-	B4 →	B1
Diagnosis		1 <sup>2</sup> bl	B3 →	B2
Plus signal ADR auxiliary drive		1 <sup>2</sup> vi	B2 →	B3
External control Water pump		-	B1 →	remains unused*
Relay, blower		1 <sup>2</sup> rt/ge	A4 →	C1
D+ for ADR mode		1 <sup>2</sup> vi/gn	A3 →	C2
Temperature drop		-	A2 →	C3
Heater ON		1 <sup>2</sup> ge	A1 →	C4

\*External control of the water pump is not planned for Hydronic M-II.

# AUXILIARY HEATER

## Hydronic M-II

### Parts list for the circuit diagrams Hydronic M-II – 12 Volt / 24 Volt

- 1.1 Burnerengine
- 1.2 Glow plug 1
- 1.2.1 Glow plug 2 (optional 12kW / FAME)
- 1.5 Overheatingsensor
- 1.12 Flamesensor
- 1.13 Temperaturesensor
- 2.1 Controller
- 2.2 Dosingpump
- 2.5.7 Relay, vehicle fan
- 2.5.18 Relay, water circuit change-over – to be fitted by the customer as required.
- 2.7 Main fuse 12 volt = 20 A  
24 volt = 15 A
- 2.7.1 Fuse, actuation 5A
- 2.7.5 Fuse, vehicle fan 25 A
- 2.12 Waterpump
- 5.1 Battery
- 5.10 Vehicle fan

a) Connection for control unit

12-pin connection pin assignment  
(external)

PIN-No.	Connection	Cable cross-section mm <sup>2</sup>
A1	Dosing pump	1.5
B1	Solenoid valve, optional	1.0
C1	Relay, blower	1.0
A2	Terminal 31	4.0
B2	Diagnosis cable (OEM)	-
C2	unused	-
A3	Terminal 30	4.0
B3	unused	-
C3	Temperature drop	1.0
A4	Plus signal output.	1.5
B4	Diagnosis (HELJED)	1.0
C4	Heater ON	1.0

b) Water circuit change-over: Relay makes contact at 68 °C and breaks contact at 63 °C water temperature (with temperature drop 58 °C / 45 °C)

c) Heaterconnection

d) Temperature drop (with positive signal)  
e) Connect the cables in the control's connector

x) Disconnectable

a2) Diagnosis

a3) Switch-on signal S+

a4) Power supply plus, +30

a5) Power supply minus, –31

a6) (+) Release the battery disconnecting switch (diode: order no. 208 00 012)

Connectors and bush housings are shown from the cable inlet side.

# AUXILIARY HEATER

Hydronic M-II



## Please note!

To connect the control units

- for EasyStart R+ / R / T: use the 0.752 bl/ws cable, heater connector B2, chamber B4,
- for all other control units: use the 0.752 ge cable, heater connector B2, chamber C4, • See page 32 for circuit diagram.

## Cable colours

rt = red

bl = blue

ws = white

sw = black

gn = green

gr = grey

ge = yellow

vi = violet

# AUXILIARY HEATER

## Hydronic M-II

Circuit diagram Hydronic M-II – 12 Volt / 24 Volt

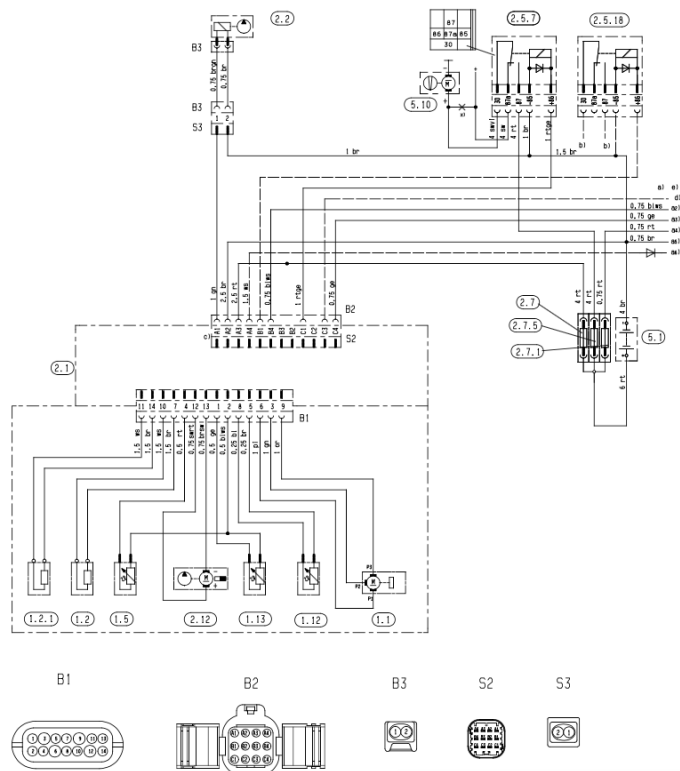

25 2435 00 96 01

# AUXILIARY HEATER

## Hydronic M-II

### Parts list for the circuit diagrams Hydronic M-II, 12 Volt / 24 Volt, ADR

- 1.1 Burnerengine
- 1.2 Glow plug 1
- 1.2.1 Glow plug 2
- 1.5 Overheating switch
- 1.12 Flamesensor
- 1.13 Temperature sensor
- 2.1 Controller
- 2.2 Fuel dosing pump
- 2.5.7 Relay, vehicle fan
- 2.5.18 Relay, changeover water circuit  
To be fitted by customer if required
- 2.7 Main fuse  
12 volt = 20 A  
24 volt = 15 A
- 2.7.1 Fuse, actuation 5A
- 2.7.5 Fuse, vehicle fan 25 A
- 2.12 Waterpump
- 5.1 Battery
- 5.10 Vehicle fan
- 5.2.1 Battery main switch (operation e.g.  
separate from ignition lock), g)
- 5.2.2 Battery disconnection switch  
(EMERGENCY OFF function for ADR), g)
- 5.10 Vehiclefan

#### a) Connection for control unit

#### 12-pin connection pin assignment (external)

PIN-No.	Connection	Cable cross-section mm <sup>2</sup>
A1	Dosing pump	1.5
B1	Solenoid valve, optional	1.0
C1	Relay, blower	1.0
A2	Terminal 31	4.0
B2	Diagnosis cable (OEM)	-
C2	D+	1.0
A3	Terminal 30	4.0
B3	TRS signal (ADR)	1.0
C3	Temperature drop	1.0
A4	Plus signal output	1.5
B4	Diagnosis (HELJED)	1.0
C4	Heater ON	1.0

- b) For ADR D+ (dynamo)
- c) For ADR HA+ (auxiliary drive/ secondary drive) minus circuit, if not present, route lead to +
- d) Changeover water circuit: relay closes at 68 °C and opens at 63 °C water temperature (with temperature decrease 58 °C / 45 °C)
- e) Connectionheater
- f) Temperature drop (with plus signal)
- g) If only one switching element is used for items 5.2.1 and 5.2.2, it is necessary to ensure that on pressing the battery disconnecting switch (EMERGENCY OFF function in ADR), the switch always breaks contact immediately (regardless of the heater condition) and all the heater's circuits are disconnected from the battery.
- h) Connect the cables in the control's connector x) Disconnect lead
  - a1) ADR feedback
  - a2) Dagnosis
  - a3) Switch-on signal S+
  - a4) Power supply plus +30
  - a5) Power supply minus -31
  - a6) (+) Trigger battery disconnecting switch (diode: order no. 208 00 012)

# AUXILIARY HEATER

## Hydronic M-II

Connectors and bush housings are shown from the cable inlet side.



### Please note!

To connect the control units

- for EasyStart R+ / R / T: use the 0.752 bl/ws cable, heater connector B2, chamber B4,
- for all other control units: use the 0.752 ge cable, heater connector B2, chamber C4,
- See page 34 for circuit diagram.

### Cable colours

rt	=	red
bl	=	blue
ws	=	white
sw	=	black
gn	=	green
gr	=	grey
ge	=	yellow
vi	=	violet

# AUXILIARY HEATER

Hydronic M-II

Circuit diagram Hydronic M-II, 12 Volt / 24 Volt, ADR

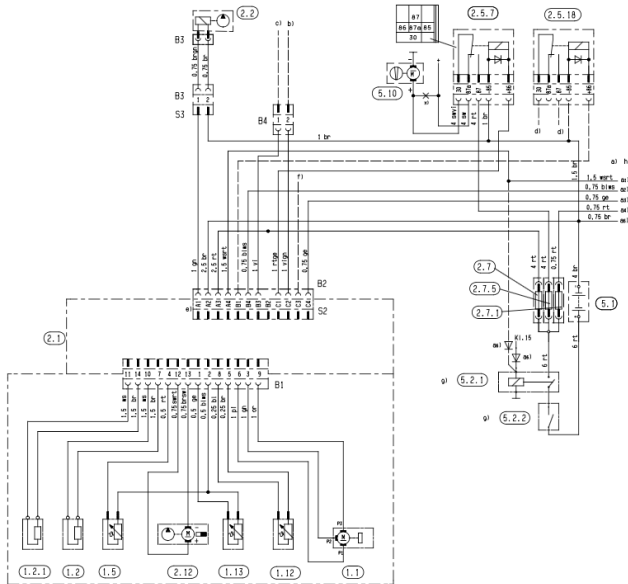

B1

B2

B3

S2

S3

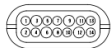

25 2435 00 96 02

# AUXILIARY HEATER

## Hydronic M-II

### Parts list for the circuit diagrams for the control elements EasyStart R+ / EasyStart R / EasyStart T and EasyStart T – ADR

- 2.15.1 Temperature sensor (room temperature) (included in the EasyStart R+ scope of supply, optional for EasyStart T)
- 2.15.9 External temperature sensor
- 3.1.7 "ON / OFF" button
- 3.1.16 Radio remote control button
- 3.2.15 EasyStart T timer
- 3.3.9 EasyStart R radio remote control (stationary unit)
- 3.3.10 EasyStart R+ radio remote control (stationary unit)
- 3.6.1 Adaptercable
- 3.8.3 Antenna

- c) Terminal 58 (lighting)
- e) EasyStart T timer connection
- g) External "ON / OFF" button (optional)
- x) ADRjumper



### Please note!

- The timer / radio remote control must be connected in accordance with the circuit diagrams (page 36 – 39).
- Insulate unused cable ends.
- Connectors and bush housings are shown from the cable inlet side.

### Cable colours

- rt = red
- bl = blue
- ws = white
- sw = black
- gn = green
- gr = grey
- ge = yellow
- vi = violet



# AUXILIARY HEATER

Hydronic M-II

Circuit diagram for the control element EasyStart R+

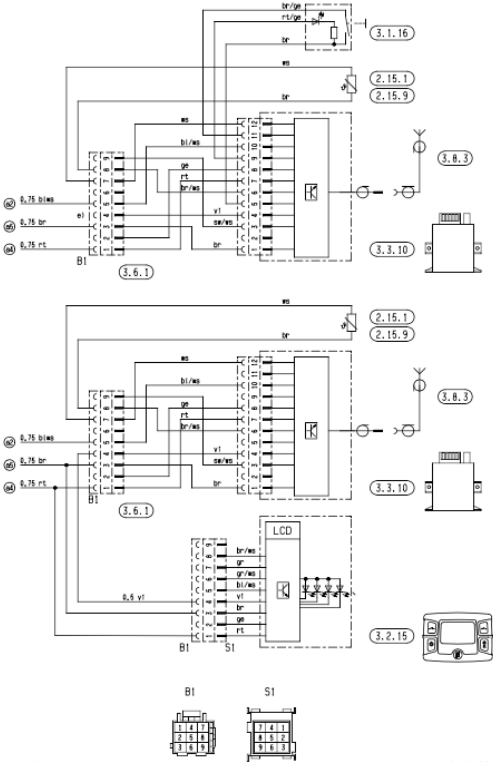

25 2435 00 97 01 A

# AUXILIARY HEATER

## Hydronic M-II

Circuit diagram for the control element EasyStart R

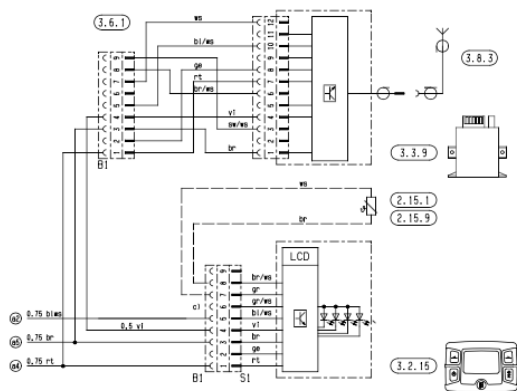
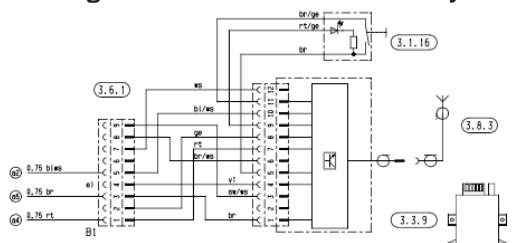

25 2435 00 97 02 A

# AUXILIARY HEATER

Hydronic M-II

Circuit diagram for the control element EasyStart T

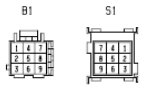
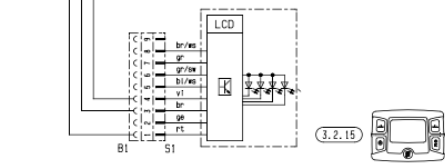
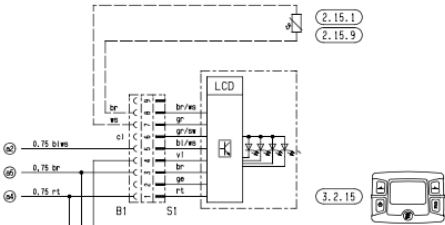
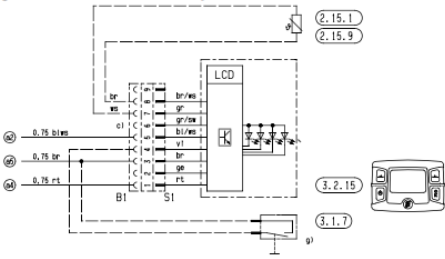

25 2435 00 97 02 A

# AUXILIARY HEATER

## Hydronic M-II

### Circuit diagram for the control element EasyStart T – ADR

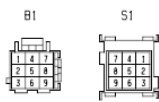
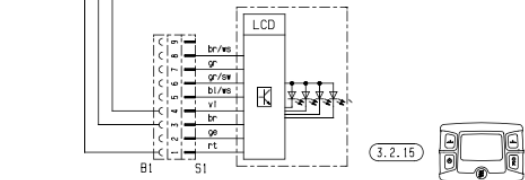
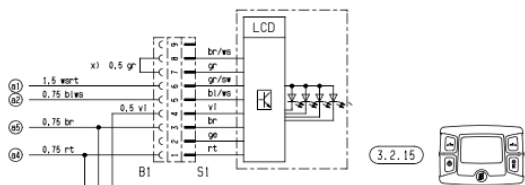
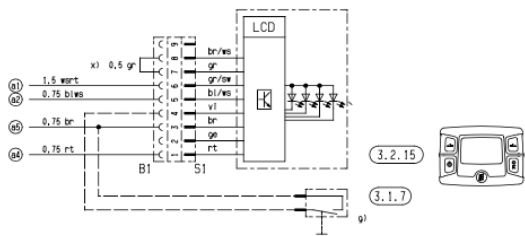

25 2435 00 97 04 A

# AUXILIARY HEATER

## Hydronic M-II

### In case of faults, please check the following points

- If the heater does not start after being switched on: – Switch the heater off and on again.
- If the heater still does not start, check whether:
  - There is fuel in the tank?
  - The fuses are OK?
  - The electrical cables, connections etc. are OK?
  - Anything is clogging the combustion air supply or exhaust system?
- Check the openings of the combustion air supply and exhaust system after longer standstill periods, clean if necessary!

### Troubleshooting

If the heater remains faulty even after these points have been checked, or another malfunction occurs in your heater, please contact:

- For installation ex works, your contract workshop.
- For subsequent installation, the workshop who installed your heater.
- 



### Please note!

Please note that warranty claims can be become void if the heater is changed by a third party or by this installation of third party parts.

### Maintenance instructions

- Switch the heater on once a month for about 10 minutes, even outside the heating period.
- Before the heating period starts, the heater should undergo a trial run. If persistent extreme smoke develops, unusual burning noises or a clear fuel smell can be perceived or if electric / electronic parts heat up, the heater must be switched off and put out of service by removing the fuse.  
In this case, the heater should not be started up again until it has been checked by qualified staff who have been trained on Eberspächer heaters.

### Service

If you have any technical queries or problems with your pre-heater, dial the following service phone number:

Hotline

Phone 00 49 (0)800 / 12 34 300

Fax hotline

Fax 00 49 (0)1805 / 26 26 24

Outside of Germany, please contact the respective national Eberspächer service agent.

# AUXILIARY HEATER

## Hydronic M-II

### Certification

The high quality of Eberspächer's products is the key to our success.

To guarantee this quality, we have organised all work processes in the company along the lines of quality management (QM).

Even so, we still pursue a large number of activities for continuous improvement of product quality in order to keep pace with the similarly constantly growing requirements made by our customers.

All the steps necessary for quality assurance are stipulated in international standards.

This quality is to be considered in a total sense.

It affects products, procedures and customer/supplier relationships.

Officially approved public experts assess the system and the corresponding certification company awards a certificate. Eberspächer has already qualified for the following standards:

**Quality management as per  
DIN EN ISO 9001:2000 and ISO/TS  
16949:1999**

### Environment management system as per DIN EN ISO 14001:1996

#### Disposal

##### Disposal of materials

Old devices, defect components and packaging material can all be separated and sorted into pure-grade fractions so that all parts can be disposed of as required in an environment-friendly manner or recycled where applicable. Electric motors, controllers and sensors (e.g. temperature sensors) are deemed to be "electronic scrap".

##### Dismantling the heater

The heater is dismantled according to the repair stages in the current troubleshooting / repair instructions.

#### Packaging

The packaging of the heater can be kept in case it has to be sent back.

### EU Declaration of Conformity

With regard to the following products

### Heater type Hydronic M-II

we herewith confirm that it conforms with the prime safety requirements stipulated in the directives of the EU Council for harmonisation of the legal regulations of the member states with regard to electromagnetic compatibility (89 / 336 / EEC).

This declaration applies to all heaters produced according to the production drawings Hydronic M-II which are an integral part of this declaration.

The following standards / directives have been used to assess the product with regard to electromagnetic compatibility:

- EN 50081 – 1 Basic form interference emission.
- EN 50082 – 1 Basic form interference resistance.
- 72 / 245 / EEC – Modification status 2006 / 28 / EG interference suppression in motor vehicles.

### **Declaration of Conformity**

Your vehicle may have components that transmit and receive radio waves and are therefore subject to government regulations.

These components must accept all interference received, including that which may cause undesired operation.

Visit

<https://www.fordtrucks.com.tr/en/conformity>

for certification labels and declaration of conformity.